

**Exhibit C-1**  
**Project Site Plan Rendering**

**City Council:**  
**Costco Commercial Center Project**

# PROJECT DATA

CLIENT: COSTCO WHOLESALE  
999 LAKE DRIVE  
ISSAQUAH, WA 98027

PROJECT ADDRESS: NEC OF I-35 & NE 36TH ST  
FRESNO, CA

ACCESSOR'S PARCEL NUMBER: 503-020-12

## SITE DATA:

COSTCO SITE AREA: 21.20 ACRES (923,869 SF)  
FUEL PARCEL AREA: 1.33 ACRES (57,753 SF)  
**TOTAL SITE AREA 22.53 ACRES (981,622 SF)**

JURISDICTION: CITY OF FRESNO

EXISTING ZONING: CC/EA/cz  
PROPOSED ZONING: CG/cz

SETBACKS:	REQUIRED	ACTUAL
FRONT:	TBD	TBD
SIDE:	TBD	TBD
REAR:	TBD	TBD

## BUILDING DATA:

TOTAL BUILDING FOOTPRINT AREA:	219,216 SF
INCLUDES:	
<b>GROSS WAREHOUSE</b>	<b>167,960 SF</b>
INCLUDES NET MECHANICAL / FIRE	1,188 SF
INCLUDES OPEN CANOPY	3,233 SF
GROSS MDO	46,834 SF

## PARKING DATA:

TOTAL SITE PARKING:	873 STALLS
INCLUDES:	
10' WIDE STALLS	808 STALLS
ACCESSIBLE STALLS	25 STALLS
TOTAL RECEIVING PARKING:	40 STALLS
INCLUDES:	
10' WIDE STALLS	40 STALLS
EV STALL PARKING	92 STALLS

NUMBER OF STALLS PER 1000 SF OF BUILDING AREA:	3.98 STALLS
12' WIDE TRAILER PARKING	33 STALLS

NOTES:  
EXISTING CONDITIONS TO BE FIELD VERIFIED.

ANY SURVEY MONUMENTS WITHIN THE AREA OF CONSTRUCTION SHALL BE PRESERVED OR RESET BY A PERSON LICENSED TO PRACTICE LAND SURVEYING IN THE STATE OF CALIFORNIA

REPAIR ALL DAMAGED AND/OR OFF-GRADE CONCRETE STREET IMPROVEMENTS, AS DETERMINED BY THE CONSTRUCTION MANAGEMENT ENGINEER, PRIOR TO OCCUPANCY

2 WORKING DAYS BEFORE COMMENCING EXCAVATION OPERATIONS WITHIN THE STREET RIGHT-OF WAY AND/OR UTILITY EASEMENTS, ALL EXISTING UNDERGROUND FACILITIES SHALL HAVE BEEN LOCATED BY UNDERGROUND SERVICES ALERT (USA). CALL 1-800-642-2444

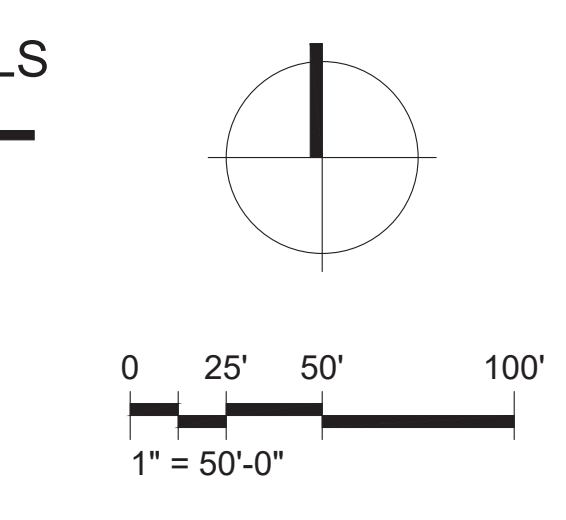

1101 Second Ave, Ste 100  
Seattle, WA 98101  
206 962 6500  
MG2.com



NOVEMBER 14, 2023

CONCEPT SITE PLAN

D11-34

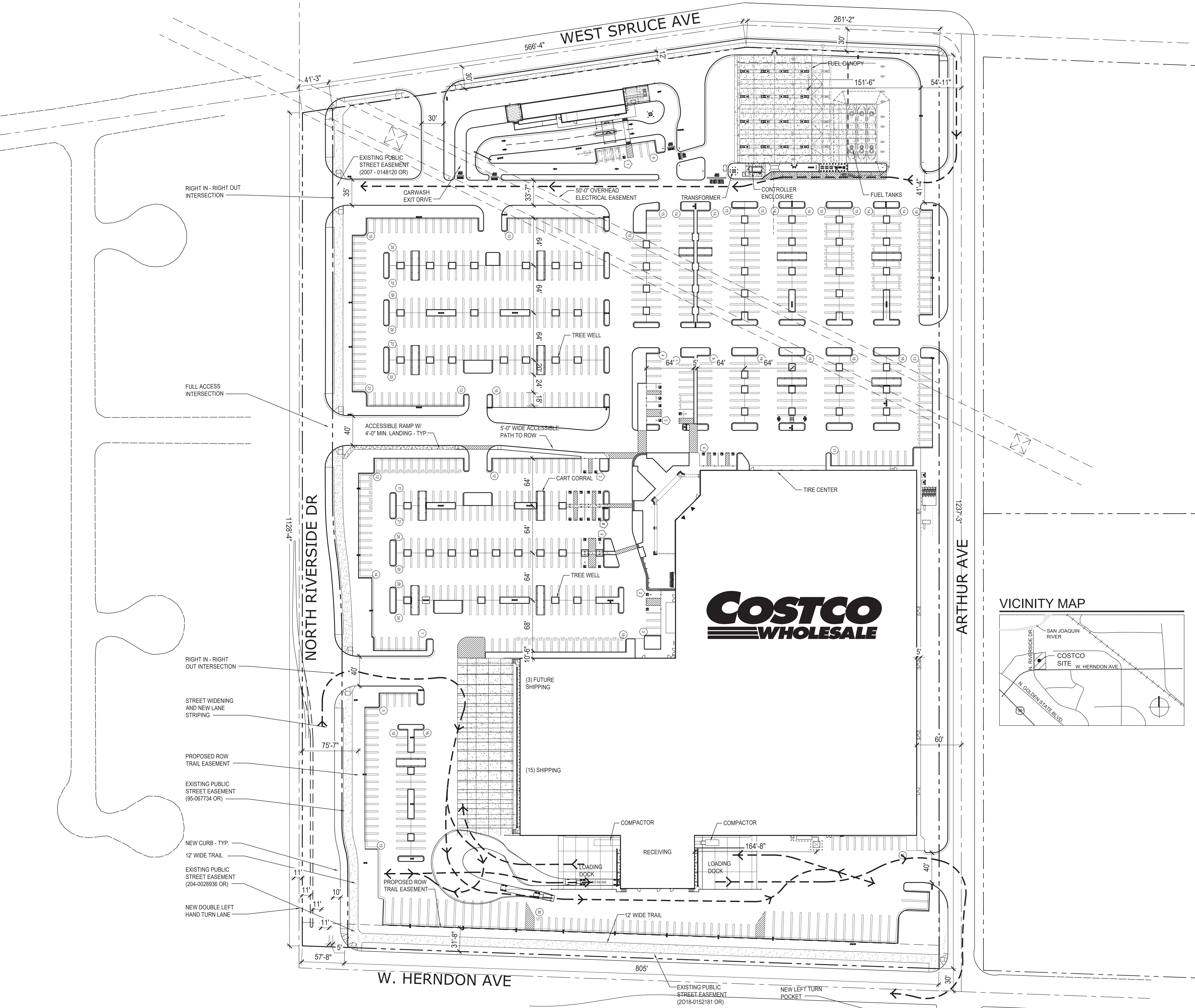

# CONCEPT SITE PLAN