

## Exhibit A

APPL. NO. T-6345 EXHIBIT A-1 DATE 05/16/2022  
 PLANNING REVIEW BY DATE  
 TRAFFIC ENG. DATE  
 APPROVED BY DATE  
 CITY OF FRESNO DARM DEPT

# VESTING TENTATIVE TRACT MAP NO. 6345

IN THE UNINCORPORATED AREA OF THE COUNTY OF FRESNO, STATE OF CALIFORNIA  
 MAY 2022  
 CONSISTING OF THREE (3) SHEETS

**ABBREVIATIONS:**  
 A.P.N. ASSESSOR'S PARCEL NUMBER  
 D.N. DOCUMENT NUMBER PER OFFICIAL RECORDS OF FRESNO COUNTY  
 F.C.R. FRESNO COUNTY RECORDS  
 LE LANDSCAPE EASEMENT (PROPOSED)  
 PUE PUBLIC UTILITY EASEMENT (PROPOSED)  
 R RADIUS  
 RS-5 RESIDENTIAL SINGLE FAMILY (5 DWELLING UNITS/ACRE)  
 R/W RIGHT OF WAY  
 SSMH SANITARY SEWER MANHOLE  
 S.P.R.R. SOUTHERN PACIFIC RAILROAD  
 XX PLATS YY VOLUME XX OF PLATS, PAGE YY, F.C.R.  
 XX RS YY BOOK XX OF RECORD OF SURVEYS, PAGE YY, F.C.R.

**LEGAL DESCRIPTION**  
 REAL PROPERTY IN THE UNINCORPORATED AREA OF THE COUNTY OF FRESNO, STATE OF CALIFORNIA, DESCRIBED AS FOLLOWS:  
 LOTS 15 AND 16 OF NEWHALL TRACT, ACCORDING TO THE MAP THEREOF, RECORDED IN BOOK 2, PAGE 42 OF RECORD OF SURVEYS, IN THE OFFICE OF THE COUNTY RECORDER OF SAID COUNTY.  
 APN: 481-020-01  
**NOTES:**  
 DATE OF MAP PREPARATION: APRIL, 2021  
 REVISED: SEPTEMBER 2021 & MAY 2022

**UTILITY INFORMATION**

**SEWER AND WATER**  
 CITY OF FRESNO  
 2600 FRESNO STREET  
 FRESNO, CA 93721  
 PHONE: (559) 621-2489

**GAS AND ELECTRIC**  
 PACIFIC GAS AND ELECTRIC COMPANY  
 650 O STREET  
 FRESNO, CA 93721  
 PHONE: (800) 743-5000

**TELEPHONE**

AT&T CALIFORNIA  
 5555 EAST OLIVE AVENUE,  
 RM. E-100-DE  
 FRESNO, CA 93762  
 PHONE: (559) 454-3778

**STORM DRAIN**

FRESNO METROPOLITAN FLOOD CONTROL DISTRICT  
 5469 EAST OLIVE AVENUE  
 FRESNO, CA 93725  
 PHONE: (559) 456-3292

**LEGEND**

- CENTERLINE
- PROPERTY LINE
- EXISTING RIGHT-OF-WAY
- PROPOSED RIGHT-OF-WAY
- PROPOSED LOT LINES
- PUBLIC UTILITY EASEMENT
- EXISTING CHAIN LINK FENCE (6FT TALL)
- EXISTING BARBED WIRE FENCE (6FT TALL)
- EXISTING EDGE OF PAVEMENT
- EXISTING CURB AND GUTTER
- EXISTING WOOD FENCE (6FT TALL)
- EXISTING POWER POLE
- EXISTING TELEPHONE POLE
- EXISTING ELECTRICAL PANEL
- EXISTING ELECTRICAL VAULT
- EXISTING GUY ANCHOR
- EXISTING BOLLARD
- EXISTING SANITARY SEWER MANHOLE
- EXISTING SIGN
- EXISTING STREETLIGHT
- EXISTING ELECTRICAL LINE
- EXISTING SEWER MAIN, SIZE AS NOTED
- EXISTING TREE
- EXISTING CONTOUR LINE
- 8" W PROPOSED WATER MAIN, SIZE AS NOTED
- 8" SS PROPOSED SEWER MAIN, SIZE AS NOTED
- PROPOSED SEWER MANHOLE
- RELINQUISHMENT OF DIRECT ACCESS RIGHTS
- PROPOSED CITY RIGHT OF WAY DEDICATION
- EXISTING DEDICATION
- SHEET INDEX LINE

**TOPOGRAPHIC SURVEY**

TOPOGRAPHIC INFORMATION SHOWN ON THIS PLAN WAS COLLECTED AND PROVIDED BY QK ON AUGUST 17, 18, 20, 21 & 25 2020.

**BASIS OF ELEVATIONS**

CITY OF FRESNO BENCHMARK #810, BEING A BRASS CAP ON CURB LOCATED AT THE EAST RETURN AT THE NORTHEAST CORNER OF WILLOW AND CHURCH AVENUES.  
 ELEVATION: 298.687 FT (NGVD29)  
 THE CONVERSION FACTOR TO NAVD88 DERIVED FROM THE NOS ONLINE DATUM TOOL = +2.5 FT (NGVD29+2.5=NAVD88)

**PROJECT SITE INFORMATION**

**ADDRESS:**  
 2121 SOUTH WILLOW AVENUE  
 FRESNO, CA 93725

**RECORD OWNERSHIP:**

OHANESIAN HOLDINGS, LLC  
 3770 W WATSON AVENUE  
 FRESNO, CA 93711  
 APN: 481-020-01

**SUBDIVIDER:**

D.R. HORTON CO., INC  
 419 W MURRAY AVENUE  
 VISALIA, CA 93291  
 (559) 636-9850

**LAND SURVEYOR:**

ANTONIO S. WESTERLUND, PLS, CFeDs  
 601 POLLASKY AVE  
 SUITE 301  
 CLOVIS, CA 93612  
 (559) 449-2400

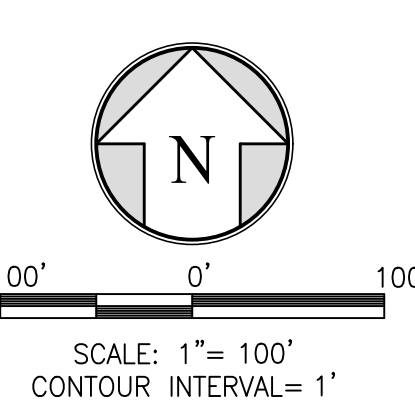
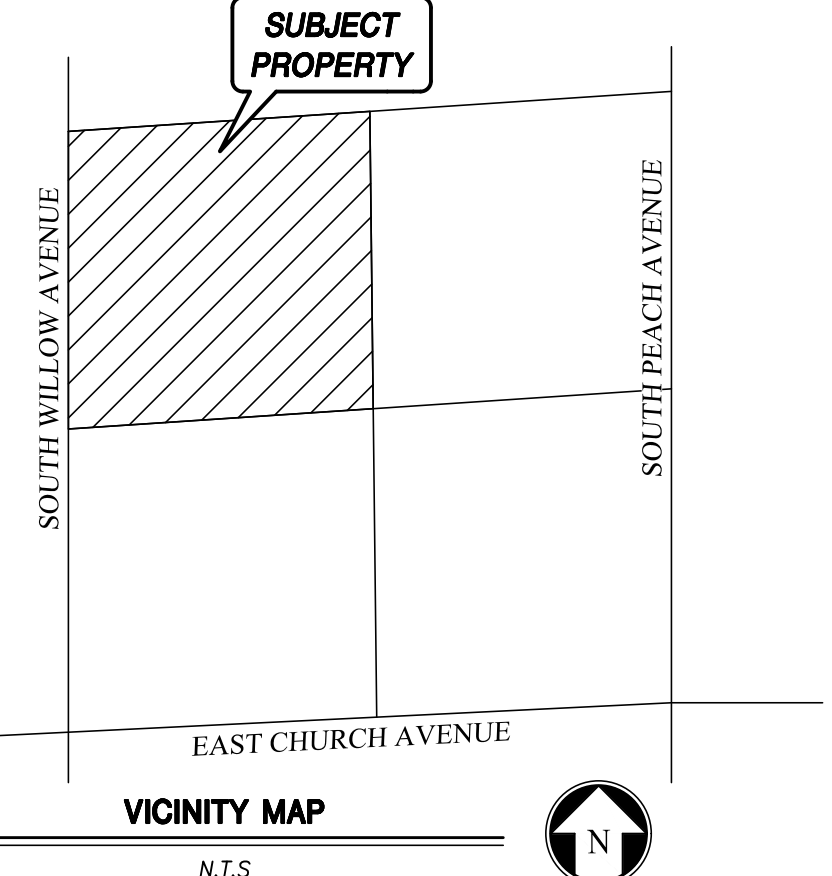
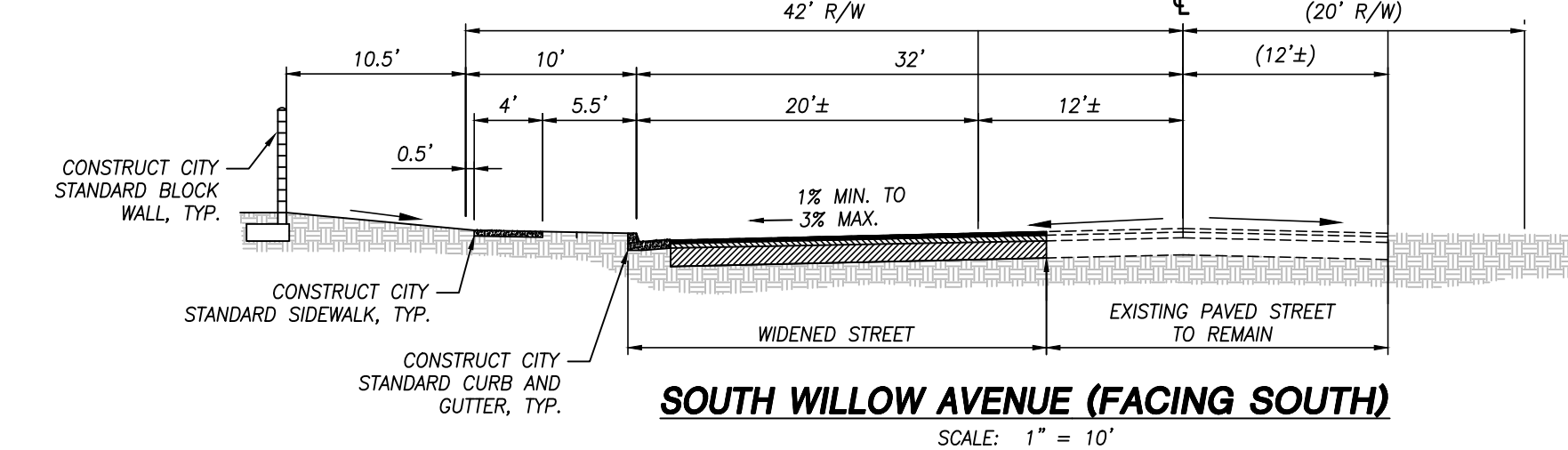
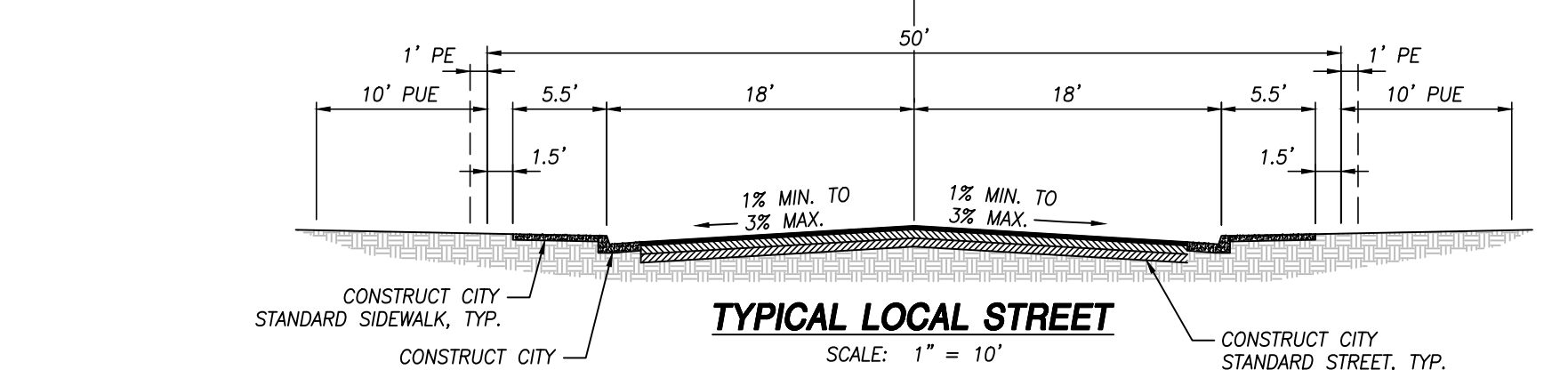

BY: **QK**  
 601 POLLASKY AVE., STE. 301 TEL: (559) 449-2400  
 CLOVIS, CA 93612 WWW.QKINC.COM  
 © COPYRIGHT BY QUAD KNOPP, INC. UNAUTHORIZED USE PROHIBITED.

# VESTING TENTATIVE TRACT MAP NO. 6345

IN THE UNINCORPORATED AREA OF THE COUNTY OF FRESNO, STATE OF CALIFORNIA  
MAY 2022  
CONSISTING OF THREE (3) SHEETS

APPL. NO. T-6345 EXHIBIT A-2 DATE 05/16/2022  
PLANNING REVIEW BY \_\_\_\_\_ DATE \_\_\_\_\_  
TRAFFIC ENG. \_\_\_\_\_ DATE \_\_\_\_\_  
APPROVED BY \_\_\_\_\_ DATE \_\_\_\_\_  
CITY OF FRESNO DARM DEPT

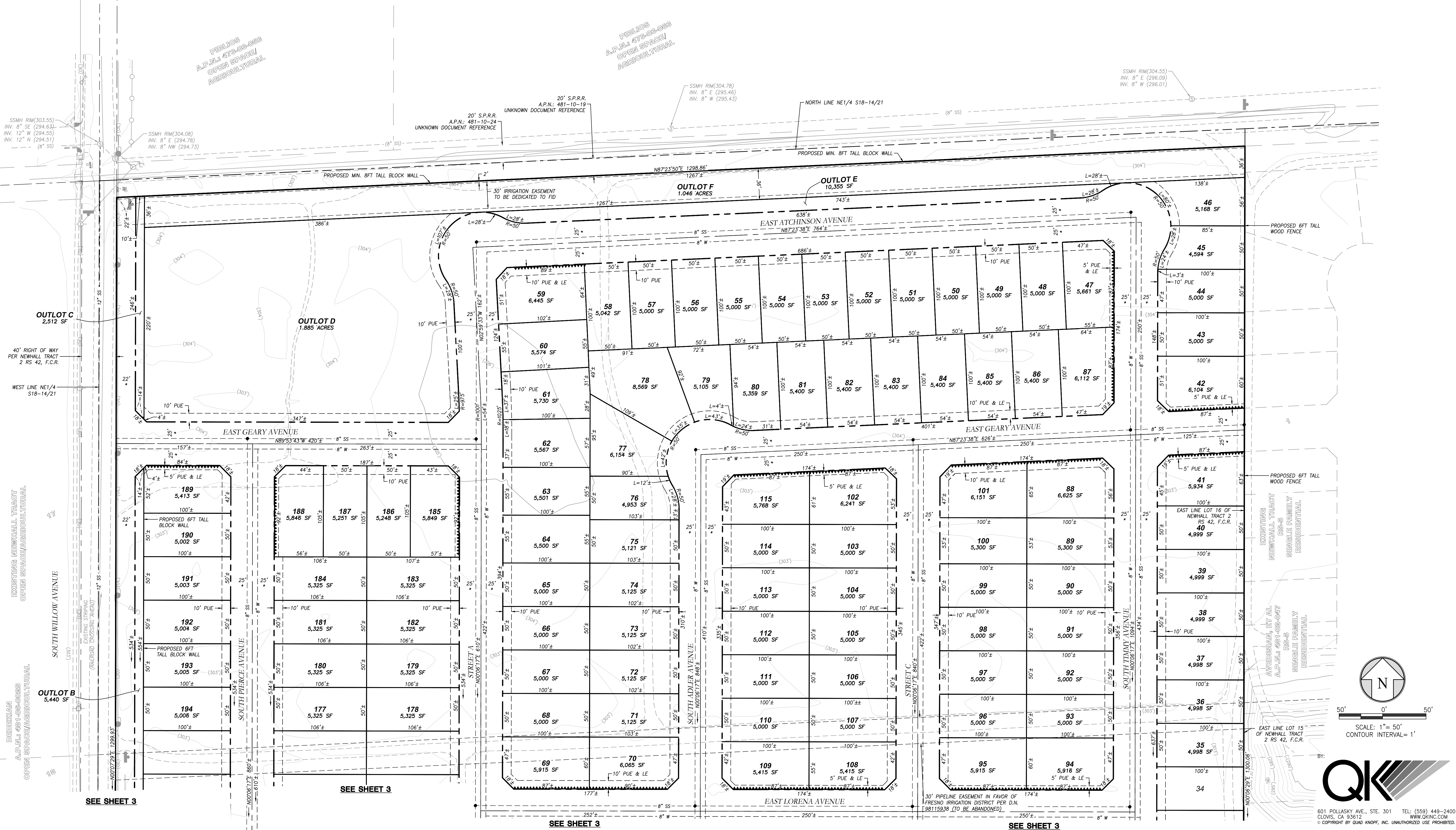

SEE SHEET 1 FOR STREET SECTION DETAILS AND LEGEND

SEE SHEET 3

SEE SHEET 3

SEE SHEET 3

SEE SHEET 3

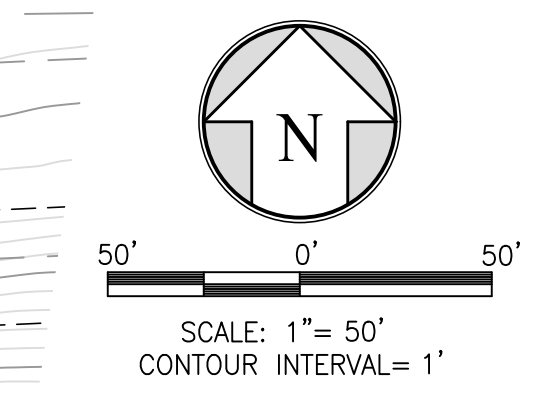

**QK**  
601 POLLASKY AVE., STE. 301 TEL: (559) 449-2400  
CLOVIS, CA 93612 WWW.QKINC.COM  
© COPYRIGHT BY QUAD KNOPP, INC. UNAUTHORIZED USE PROHIBITED.

APPL. NO. T-6345 EXHIBIT A-3 DATE 05/16/2022  
 PLANNING REVIEW BY \_\_\_\_\_ DATE \_\_\_\_\_  
 TRAFFIC ENG. \_\_\_\_\_ DATE \_\_\_\_\_  
 APPROVED BY \_\_\_\_\_ DATE \_\_\_\_\_  
 CITY OF FRESNO DARM DEPT

# VESTING TENTATIVE TRACT MAP NO. 6345

IN THE UNINCORPORATED AREA OF THE COUNTY OF FRESNO, STATE OF CALIFORNIA  
 MAY 2022  
 CONSISTING OF THREE (3) SHEETS

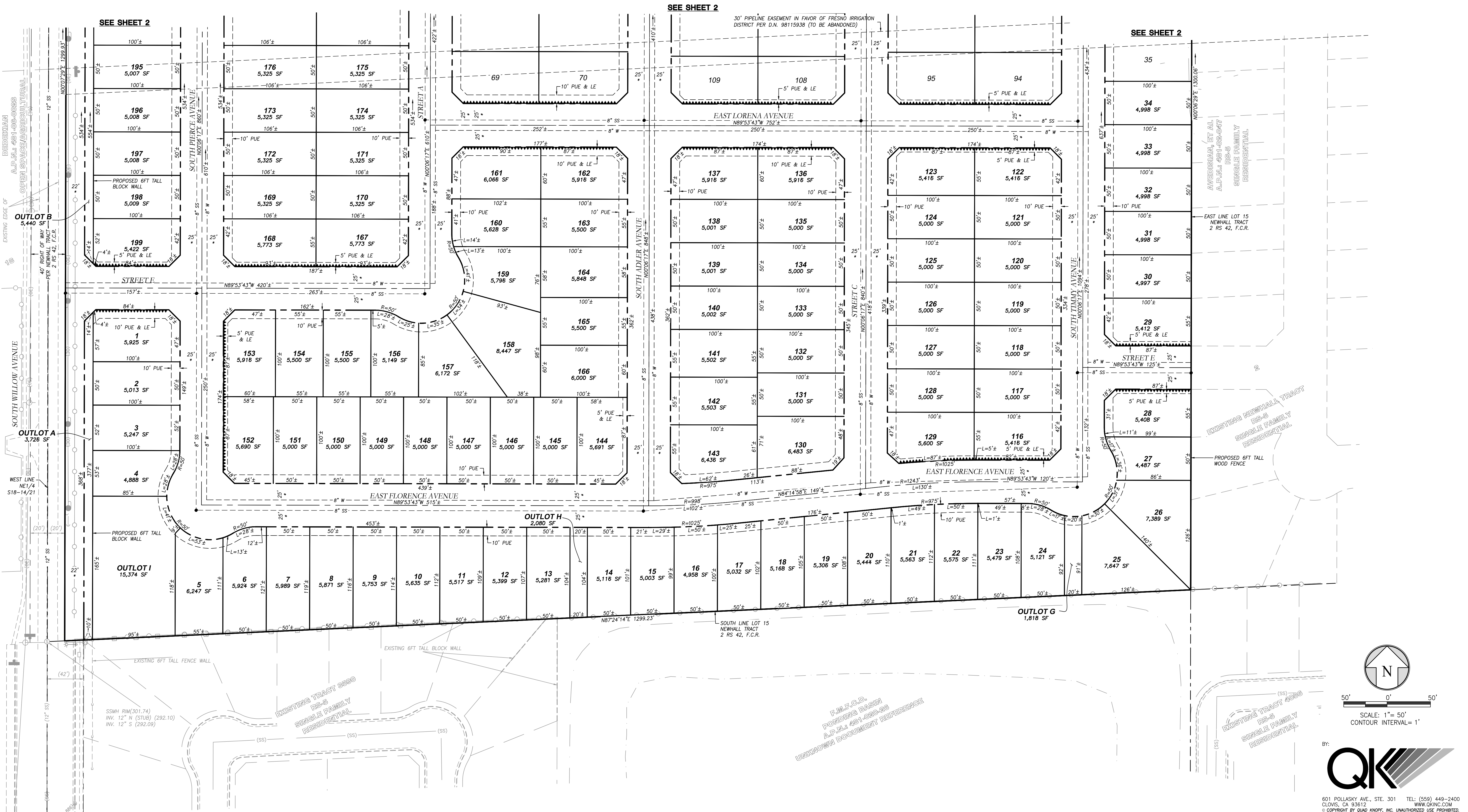

SEE SHEET 1 FOR STREET SECTION DETAILS AND LEGEND

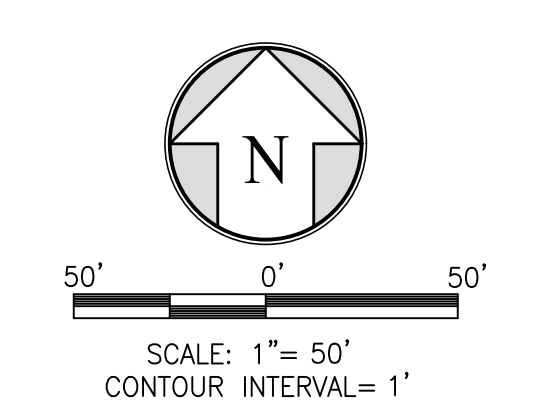

BY: **QK**  
 601 POLLASKY AVE., STE. 301 TEL: (559) 449-2400  
 CLOVIS, CA 93612 WWW.QKING.COM  
 © COPYRIGHT BY QUAD KNOPP, INC. UNAUTHORIZED USE PROHIBITED.