



**FINANCE DEPARTMENT
PURCHASING UNIT**

BID SPECIFICATIONS

**PRODUCT PURCHASE CONTRACT FOR:
Two (2) 40' Low Floor Regular All-Electric Fixed Route Bus**

BID FILE NUMBER: 3604

INDEX

	<u>Page</u>
Table of Content	2
Notice Inviting Bids	13
Instructions to Bidders	16
Bidder's Checklist	20
Bid Proposal	21
Time Period to Award/Reject Bid	22
Contract Document	24
General Conditions	25
Federal Requirements	39
Special Conditions	51
Technical Specifications	61
Warranty Requirements	180
Quality Assurance	188
Forms and Certifications	202
Appendixes and Exhibits	236

BID NUMBER: 3604

SCHEDULED BID OPENING: (Prior to 3:00 p.m., on 6/26/18)

PROCUREMENT SPECIALIST: Alex Nazaroff

PURCHASING UNIT

Phone: (559) 621-8361 OR 621-1332

Fax: (559) 457-1522

CITY OF FRESNO SPECIFICATIONS

PRODUCT PURCHASE CONTRACT FOR:
Two (2) 40' Low Floor Regular All-Electric Fixed Route Bus

BID FILE NUMBER: 3604

TABLE OF CONTENTS

	<u>Page</u>
TABLE OF CONTENTS	2
SECTION 1: NOTICE INVITING BIDS	13
NR 1. General Description	13
NR 2. Description of the Work to be Done	14
NR 3. Vehicle Design.....	14
NR 4. Obtaining Bid Documents.....	14
NR 5. Bid Due Date and Submittal Requirements	14
NR 6. Pre-Bid Meeting Information.....	14
NR 7. Federal	15
SECTION 2: INSTRUCTIONS TO BIDDER	16
IP 1. General.....	16
IP 2. Bidder's Deposit	16
IP 2.1 Bid Deposit	16
IP 2.2 Annual Bidders Bond.....	16
IP 3. Submittal of Bid.....	17
IP 4. Contract Definitions.....	17
IP 5. Questions, Clarifications and Concerns	17
IP 6. Contacts with City Staff.....	17
IP 6.1 Regulated Communications in City Procurement Process Ordinance	18
IP 6. City Reviewed Equals.....	18
IP 7. Exceptions.....	18
IP 8. Bid Appeal Procedure	18
IP 9. Debarment.....	19
IP 10. ADA.....	19
IP 11. ACH Payment Initiative-Electronic Payment	19
IP 12. Bidder's Checklist.....	20
IP 13. Bid Proposal.....	21
IP 14. Contract Quantities	22
IP 15. Addenda	22
IP 16. Public Records	22
IP 17. Contract Documents.....	22
IP 18. Precedence of Bid Prices	22
IP 19. Right to Reject Any and All Bids	22
IP 20. Time Period to Award/Reject Bids	22
IP 21. Award of Contract.....	23
IP 22. Notification of Staff Determination	23
IP 23. Minor Irregularities	23
IP 24. Tiebreaker	23
IP 25. Contract Documents.....	24
SECTION 3: GENERAL CONDITIONS	25
GC 1. Definitions.....	25
GC 2. Products Liability Insurance	25

GC 3. Indemnification	25
GC 4. Federal Immigration Reform and Control Act Of 1986.....	26
GC 5. Workmanship Guaranty	26
GC 6. Warranty	26
GC 7. Precedence Of Contract Documents	26
GC 8. Contract Documents.....	26
GC 9. Assignment of Payment	27
GC 10. Patents	27
GC 11. OSHA Compliance	27
GC 12. Recycling Program.....	27
GC 13. Sustainability.....	27
GC 14. Delivery and Extensions	28
GC 15. Contract Documents.....	28
GC 16. Payment	28
GC 17. Funding	28
GC 18. Termination For Convenience	28
GC 19. Termination For Non-Performance.....	29
GC 20. Termination by City for Non-Appropriation	29
GC 21. Independent Contractor.....	29
GC 22. Notices	30
GC 23. Binding.....	30
GC 24. Assignment	30
GC 25. Compliance with Laws and Regulations.....	30
GC 26. Changes of Law	30
GC 27. Governing Law and Choice of Forum	30
GC 28. Waiver.....	30
GC 29. Headings	31
GC 30. Severability	31
GC 31. Interpretation.....	31
GC 32. Attorney’s Fees	31
GC 33. Exhibits	31
GC 34. Cumulative Remedies	31
GC 35. No Third Party Beneficiaries	31
GC 36. Funding	31
GC 37. Governing Law and Venue	31
GC 38. Extent of Contract.....	32
GC 39. Modifications and Change Orders	32
GC 40. Alteration of Terms.....	32
GC 41. Contract Changes	32
GC 42. Amendments	32
GC 43. DBE Requirements for Transit Vehicle Manufacturers.....	32
GC 44. Buy America Certification.....	32
GC 45. FTA Review.....	33
GC 46. Materials and Workmanship	34
GC 47. Conformance with Specifications and Drawings.....	34
GC 48. Inspection, Testing and Acceptance.....	34
GC 48.1 General.....	34
GC 48.2 Risk of Loss	35
GC 49. Title and Warranty of Title	35
GC 50. Intellectual Property Warranty.....	35
GC 51. Data Rights.....	35
GC 51.1 Proprietary Rights/Rights in Data.....	35
GC 51.2 Access to Onboard Operational Data.....	36

GC 51.3 Maintenance of Records; Access by City; Right to Audit Records	36
GC 52. Suspension of Work	37
GC 53. Claims and Disputes	37
GC 53.1 General.....	37
SECTION 4: FEDERAL REQUIREMENTS	39
FR 1. Termination	39
FR 1.1 Termination for Convenience	39
FR 1.2 Termination for Default.....	40
FR 1.3 Opportunity to Cure (General Provision)	40
FR 1.4 Waiver of Remedies for any Breach.....	41
FR 2. Compliance with Federal Lobbying Policy	41
FR 3. Employee Protections	41
FR 4. Clean Air Act and Federal Water Pollution Control Act.....	41
FR 5. Violation and Breach of Contract	42
FR 6. Buy America.....	43
FR 7. Suspension and Debarment	43
FR 8. Access to Records and Reports.....	44
FR 9. Changes to Federal Requirements	45
FR 10. Civil Rights Requirements.....	45
FR 11. Disadvantaged Business Enterprise (DBE)	46
FR 12. Federal Energy Conservation Requirements	47
FR 13. Federal Funding, Incorporation of FTA Terms and Federal Changes.....	47
FR 14. No Government Obligation to Third Parties	48
FR 15. Safe Operation of Motor Vehicles	48
FR 16. Recycled Products	48
FR 17. Fly America	48
FR 18. Cargo Preference Requirements	49
FR 19. Program Fraud and False, Fraudulent Statements or Related Acts	49
FR 20. Bus Testing.....	50
FR 21. Pre-Award and Post-Delivery Audits	50
SECTION 5: SPECIAL CONDITIONS	51
SP 1. Pricing Conditions.....	51
SP 2. Authorization To Place Orders	51
SP 3. Contractor’s Authorized Representative	51
SP 4. Change Orders.....	51
SP 5. Deliveries	51
SP 5.1 Bus Delivery	51
SP 5.2 Delivery Schedule.....	51
SP 5.3 Non-Delivery	52
SP 5.4 Liquidated Damages	52
SP 6. Contract Deliverable Requirements List (CDRL).....	52
SP 6.1 Contract Deliverables.....	53
SP 7. Emergency Orders/Repairs	55
SP 8. Payment.....	55
SP 8.1 Payment Terms	55
SP 9. Inspection, Tests, and Repairs.....	56
SP 9.1 Repair Performance.....	56
SP 9.2 Configuration and Performance Approval	57
SP 9.3 First Article Inspection – Production	57
SP 9.4 Post-Delivery Tests	57
SP 9.5 Repairs after Non-Acceptance	57
SP 10. Service and Parts.....	58

SP 10.1 Contractor Service and Parts Support	58
SP 10.2 Documentation	58
SP 10.3 Parts Availability Guarantee	58
SP 10.4 City-Furnished Property.....	58
SP 11. Federal Motor Vehicle Safety Standards (FMVSS).....	59
SP 12. Escrow Accounts.....	59
SP 12.1 Software Escrow Account.....	59
SP 12.2 Manufacturing Data Escrow Account.....	59
SECTION 6: TECHNICAL SPECIFICATIONS	61
TS 1. General.....	61
TS 2. Explanation of Bid Items	62
TS 3. General Design	62
TS 3.1 Bus Design.....	62
TS 4. Scope.....	63
TS 5. Definitions	63
TS 6. Referenced Publications	67
TS 7. Legal Requirements	67
TS 8. Overall Requirements	68
TS 8.1 Weight.....	69
TS 8.2 Capacity	69
TS 8.3 Seating Capacity	69
TS 8.4 Service Life.....	69
TS 8.5 Maintenance and Inspection	69
TS 8.6 Interchangeability	70
TS 8.7 Deliverables	70
TS 8.8 Technical/Service Representatives	74
TS 8.9 Support Requirements.....	74
TS 8.10 Service Manuals.....	74
TS 8.11 Operating Environment.....	74
TS 8.12 Noise	75
TS 8.13 Respect for the Environment	75
TS 8.14 Omission	75
TS 9. Materials/Accessories Responsibility	76
TS 9.1 Materials	76
TS 10. Principles of Design.....	76
TS 11. Workmanship.....	77
TS 12. Dimensions	77
TS 12.1 Physical Size	77
TS 12.2 Bus Length.....	78
TS 12.3 Bus Width	78
TS 12.4 Bus Height	78
TS 12.5 Step Height	78
TS 12.6 Underbody Clearance	78
TS 12.7 Ramp Clearances	78
TS 12.8 Ground Clearance	79
TS 12.9 Floor Height.....	79
TS 12.10 Interior Headroom.....	79
TS 12.11 Aisle Width.....	79
TS 13. Fire Safety.....	80
TS 13.1 Materials	80
TS 13.2 Fire Protection.....	80
TS 13.3 Automatic Fire Suppression System (AFSS).....	80

TS 13.4 Safety Equipment.....	83
TS 14. Vehicle Performance.....	83
TS 14.1 Power Requirements	83
TS 14.2 Top Speed	83
TS 14.3 Gradability	83
TS 14.4 Acceleration	84
TS 14.5 Operating Range	84
TS 15. Fuel Economy (Design Operating Profile)	85
TS 16. Propulsion System	85
TS 16.1 Propulsion System Specifications.....	85
TS 16.2 Propulsion System Service	85
TS 16.3 Propulsion System Compartment	86
TS 16.4 Propulsion System Mounting.....	86
TS 16.5 Traction Motor.....	86
TS 16.6 Jerk.....	86
TS 17. Transmission (If Applicable)	87
TS 18. Regenerative Braking	87
TS 19. Propulsion Control Systems.....	87
TS 19.1 Electric Vehicle System Controller (EVSC).....	88
TS 19.2 Energy Storage System (ESS) Control System	89
TS 20. Energy Storage System (ESS)	90
TS 20.1 Energy Storage System (ESS) Safety	90
TS 20.2 Battery Management System (BMS)	91
TS 20.3 Battery Thermal Management	91
TS 21. Shop/Depot Charging Connection	91
TS 21.1 Bus Charging Requirements	92
TS 21.2 Plug-In Charger Requirements	92
TS 22. Cooling & Thermal Management Systems.....	92
TS 22.1 Propulsion System Thermal Management.....	92
TS 22.2 Energy Storage System (ESS) Thermal Management	95
TS 22.3 Transmission Cooling	95
TS 22.4 Radiator.....	95
TS 22.5 Coolant.....	96
TS 22.6 Drive Design	96
TS 23. Oil & Hydraulic Systems	96
TS 23.1 Lines	96
TS 23.2 Routing and Securement.....	97
TS 23.3 Clamps	97
TS 23.4 Fittings	97
TS 24. Structure.....	98
TS 24.1 General Design	98
TS 24.2 Fleet Failures.....	98
TS 24.3 Altoona Testing.....	99
TS 24.4 Structural Validation.....	99
TS 25. Water Leak Test.....	99
TS 26. Distortion	99
TS 27. Frame (If Applicable)	100
TS 28. Resonance and Vibration	100
TS 28.1 Propulsion System Compartment Bulkheads.....	100
TS 28.2 Crashworthiness.....	100
TS 29. Corrosion	101
TS 30. Towing.....	101
TS 31. Jacking	102

TS 32. Jack Stand Interface	102
TS 33. Hoisting.....	102
TS 34. Floor.....	103
TS 34.1 Design	103
TS 34.2 Strength.....	103
TS 34.3 Construction.....	103
TS 35. Platforms.....	104
TS 35.1 Operator’s Area.....	104
TS 35.2 Operator’s Platform	104
TS 35.3 Farebox	105
TS 35.4 Rear Step Area to Rear Area.....	105
TS 36. Suspension	106
TS 36.1 General Requirements.....	106
TS 36.2 Alignment	106
TS 36.3 Springs and Shock Absorbers	106
TS 37. Wheel Housing	107
TS 37.1 Design and Construction.....	107
TS 38. Wheels and Tires	108
TS 38.1 Wheels	108
TS 38.2 Tires	108
TS 39. Steering	108
TS 39.1 Steering General	108
TS 39.2 Turning Effort	109
TS 39.3 Steering Wheel and Horn – General	109
TS 39.4 Steering Column Tilt/Telescope	109
TS 40. Turning Radius	110
TS 41. Front (Steering) Axle	110
TS 42. Drive Axle And Drive Shaft	111
TS 43. Hubs.....	111
TS 44. Brakes	111
TS 44.1 Service Brake.....	111
TS 44.2 Actuation.....	111
TS 44.3 Anti-Lock Braking System	112
TS 44.4 Rotors.....	112
TS 44.5 Friction Material	112
TS 44.6 Parking/Emergency Brake	112
TS 45. Interlocks	113
TS 45.1 Passenger Door Interlocks	113
TS 45.2 Accelerator Interlock	113
TS 46. Pneumatic System.....	113
TS 46.1 General.....	113
TS 46.2 Air Compressor.....	114
TS 46.3 Air Lines and Fittings	114
TS 46.4 Air Reservoirs	114
TS 46.5 Air System Dryer	114
TS 47. Operator’s Area.....	115
TS 47.1 General.....	115
TS 47.2 Glare	115
TS 47.3 Visors/Sun Shades	115
TS 47.4 Operator’s Controls.....	116
TS 47.5 Normal Bus Operation Instrumentation and Controls	117
TS 47.6 Foot Controls	120
TS 48. Operator’s Amenities.....	121

TS 48.1 Coat Hanger	121
TS 48.2 Drink Holder	121
TS 48.3 Storage Box.....	121
TS 49. Operator’s Seat	122
TS 49.1 General.....	122
TS 49.2 Seat Structure and Materials	122
TS 49.3 Dimensions and Adjustments	123
TS 49.4 Controls.....	124
TS 49.5 Seat Back Lumbar Support	125
TS 49.6 Headrests.....	125
TS 49.7 Seat Belt.....	125
TS 49.8 Armrest	125
TS 50. Passenger Seating	125
TS 50.1 Arrangements and Seat Style	125
TS 50.2 Aisles	126
TS 50.3 Seating Dimensions	126
TS 50.4 Structure and Design.....	127
TS 50.5 Construction and Materials	129
TS 50.6 Seat Inserts.....	129
TS 51. Passenger Assists	129
TS 51.1 General.....	130
TS 51.2 Front Doorway Assist	130
TS 51.3 Vestibule	130
TS 51.4 Rear Doorway Assist	130
TS 51.5 Overhead Assist	131
TS 51.6 Longitudinal Seat Assists.....	131
TS 51.7 Wheel Housing Barriers/Assists	131
TS 52. Passenger Doors.....	131
TS 52.1 General.....	131
TS 52.2 Materials and Construction	132
TS 52.3 Dimensions	132
TS 52.4 Door Glazing.....	132
TS 52.5 Door Projection.....	133
TS 52.6 Door Height Above Pavement.....	133
TS 52.7 Closing Force.....	133
TS 52.8 Actuators.....	134
TS 52.9 Emergency Operation	134
TS 52.10 Door Control.....	135
TS 52.11 Door Interlocks	135
TS 53. Accessibility Provisions.....	136
TS 53.1 Wheelchair Ramp Loading Systems	136
TS 53.2 Wheelchair Accommodation Locations.....	138
TS 53.3 Interior Circulation	138
TS 54. Mirrors	138
TS 54.1 Exterior Mirrors	138
TS 54.2 Interior Mirrors	139
TS 55. Windows	139
TS 55.1 General.....	139
TS 55.2 Windshield.....	139
TS 55.3 Operator’s Side Window	139
TS 55.4 Side/Passenger and Door Windows	140
TS 55.5 Rear Window	141
TS 56. Windshield Wipers and Washers.....	141

TS 56.1 Windshield Wipers	141
TS 56.2 Windshield Washers	142
TS 57. Heating, Ventilating and Air Conditioning.....	142
TS 57.1 General.....	142
TS 57.2 Capacity and Performance	142
TS 57.3 Air Conditioning System	143
TS 57.4 Heater System.....	143
TS 57.5 Controls and Temperature Uniformity.....	144
TS 57.6 Air Flow.....	144
TS 57.7 Roof Ventilators.....	146
TS 57.8 Maintainability.....	146
TS 58. Exterior Panels and Finishes.....	147
TS 58.1 Design	147
TS 58.2 Materials	147
TS 58.3 Finish, Appearance, and Color.....	147
TS 58.4 Bus Design.....	148
TS 58.5 Roof-Mounted Equipment	148
TS 58.6 Pedestrian Safety.....	149
TS 58.7 Repairs and Replacement.....	149
TS 58.8 Rain Gutters	149
TS 58.9 License Plate Provisions	149
TS 58.10 Rub-Rails	149
TS 58.11 Fender Skirts.....	150
TS 58.12 Splash Aprons	150
TS 59. Service Compartments and Access Doors	150
TS 59.1 Access Doors	150
TS 59.2 Access Door Latch/Locks	151
TS 60. Bumpers.....	151
TS 60.1 Bumper Material.....	151
TS 60.2 Location	151
TS 60.3 Front Bumper.....	151
TS 60.4 Rear Bumper	151
TS 60.5 Bumper Material.....	152
TS 61. Interior Panels and Finishes.....	152
TS 61.1 General.....	152
TS 61.2 Interior Panels	152
TS 61.3 Headlining.....	154
TS 61.4 Fastening.....	154
TS 61.5 Interior Access Panels and Doors	154
TS 61.6 Insulation	155
TS 61.7 Floor Covering.....	155
TS 62. Fare Collection.....	155
TS 63. Lighting.....	156
TS 63.1 Exterior	156
TS 63.2 Interior	158
TS 64. Decals, Numbering, and Signing	160
TS 64.1 General.....	160
TS 64.2 Exterior	160
TS 64.3 Interior	160
TS 65. Electrical, Electronic and Data Communication Systems	161
TS 65.1 Overview.....	161
TS 65.2 Modular Design	162
TS 65.3 Environmental and Mounting Requirements	162

TS 65.4 Electrical Components	163
TS 65.5 Electrical Compartments.....	163
TS 65.6 General Electronic Requirements	163
TS 65.7 Batteries System	164
TS 65.8 Grounds.....	167
TS 65.9 Low Voltage/Low Current Wiring and Terminals.....	167
TS 66. Multiplexing.....	168
TS 66.1 General.....	168
TS 66.2 System Configuration	169
TS 67. Data Communications.....	169
TS 67.1 General.....	169
TS 67.2 Drivetrain Level.....	170
TS 67.3 Multiplex Level.....	170
TS 67.4 Diagnostic Ports.....	171
TS 67.5 Electronic Noise Control	171
TS 68. Make Ready Provisions, Intelligent Transportation Systems (ITS)	172
TS 68.1 Automatic Vehicle Annunciation/Automatic Vehicle Location	172
TS 69. Signage and Communication	173
TS 69.1 Destination Signs	173
TS 69.2 Passenger Stop Request/Exit Signal	174
TS 69.3 Public Address System	175
TS 69.4 Automatic Passenger Counter (APC)	176
TS 69.5 Radio Handset and Control System	176
TS 70. Camera Surveillance System	176
TS 70.1 Camera Locations	176
TS 70.2 Camera Enclosures	179
TS 70.3 Network Video Recorder (NVR).....	179
TS 71. Event Data Recorders (EDR).....	179
TS 71.1 Emergency Alarm	179
SECTION 7: WARRANTY REQUIREMENTS	180
WR 1. General	180
WR 2. Contractor Warranty	180
WR 3. Complete Bus	180
WR 4. Thermal Management System Warranty	181
WR 5. Body and Chassis Structure	181
WR 6. Propulsion System.....	181
WR 7. Battery System	181
WR 8. Shop Charging System.....	182
WR 9. Subsystems.....	182
WR 10. Serial Numbers.....	182
WR 11. Extension of Warranty	183
WR 12. Voiding of Warranty	183
WR 13. Exceptions and Additions to Warranty	183
WR 14. Pass-Through Warranty	183
WR 14.1 Superior Warranty	184
WR 15. Fleet Defects	184
WR 15.1 Occurrence and Remedy	184
WR 15.2 Exceptions to Fleet Defect Provisions	184
WR 16. Repair Performance.....	184
WR 17. Repairs by the Contractor.....	184
WR 18. Repairs by the City.....	185
WR 18.1 Parts Used	185

WR 18.2 Contractor-Supplied Parts	185
WR 18.3 Defective Component Return.....	185
WR 18.4 Failure Analysis	185
WR 18.5 Reimbursement for Labor and Other Related Costs	185
WR 18.6 Reimbursement for Parts.....	186
WR 18.7 Reimbursement Requirements	186
WR 19. Warranty after Replacement/Repairs	186
WR 19.1 Warranty Processing Procedures.....	186
WR 20. Forms	187
WR 21. Return of Parts	187
WR 22. Timeframe	187
WR 23. Reimbursements.....	187
SECTION 8: QUALITY ASSURANCE.....	188
QA 1. Contractor’s In-Plant Quality Assurance Requirements	188
QA 1.1 Quality Assurance Organization	188
QA 1.2 Quality Assurance Organization Functions	188
QA 2. Inspection.....	190
QA 2.1 Inspection Stations.....	190
QA 2.2 Resident Inspectors	190
QA 3. Acceptance Tests	191
QA 3.1 Responsibility	191
QA 3.2 Pre-Delivery Tests	191
QA 4. City-Specific Requirements.....	192
QA 4.1 CAD/AVL Inspection Sign-Off.....	192
QA 5. Bus Manufacturing Inspection Guidelines	192
QA 5.1 Pre-Production Meeting.....	192
QA 5.2 Build Schedule.....	193
QA 5.3 Plant Tour	194
QA 5.4 Prototype/Pilot Vehicle Production	194
QA 5.5 Visual and Measured Inspections	194
QA 5.6 Total Bus Operation.....	194
QA 5.7 Buy America Audit.....	196
QA 5.8 Resident Inspection Process for Serial Production	196
QA 5.9 Vehicle Inspections.....	197
QA 5.10 Audits.....	199
QA 5.11 Communications	199
QA 5.12 Documentation.....	199
QA 5.13 Vehicle Release for Delivery	200
SECTION 9: FORMS AND CERTIFICATIONS	202
CER 1. Acknowledgement of Addenda	202
CER 2. Federal Certifications.....	203
CER 2.1 Statement of Acceptance of All Federal Conditions or Requirements	203
CER 2.2 Buy America Certification.....	204
CER 2.3 Debarment and Suspension Certification for Prospective Contractor	205
CER 2.4 Debarment and Suspension Certification (Lower-Tier Covered Transaction	206
CER 2.5 Lobbying Certification.....	207
CER 2.6 Certificate of Compliance with Bus Testing Requirement	208
CER 2.7 DBE Approval Certification	209
CER 2.8 Federal Motor Vehicle Safety Standards	210
CER 3. Other Forms and Certifications.....	211
CER 3.1 Statement of Acceptance of Indemnification/Insurance Requirements	211
CER 3.2 Bid Form.....	212

CER 3.3 Bid Deposit	213
CER 3.4 Additional Information to be Provided by Proposer.....	214
CER 3.7 Signature Page	215
CER 3.8 Instructions for Signature Page.....	215
CER 3.9 Authorization Agreement for Direct Payments (ACH Credits).....	217
CER 3.10 Sample Certification	218
CER 3.11 Sample Service Contract.....	219
CER 4. Vehicle Technical Information	221
SECTION 10: APPENDIXES AND EXHIBITS.....	236
Appendix A: Performance Bond Form.....	236
Appendix B: Software Escrow Agreement	237
EXHIBIT “A”.....	243
EXHIBIT “B”.....	248
EXHIBIT “C”.....	249
EXHIBIT “D”.....	250
EXHIBIT “E”	251
EXHIBIT “F”	252
References.....	253
Abbreviation and Acronyms	254

SECTION 1: NOTICE INVITING BIDS

Sealed bids or electronic bids via Planet Bids will be received at the office of the Purchasing Manager of the City of Fresno, 2600 Fresno Street, Room 2156, Fresno, California 93721, all in accordance with the Specifications for:

PRODUCT PURCHASE CONTRACT FOR:
Two (2) 40' Low Floor Regular All-Electric Fixed Route Bus

BID FILE NUMBER: 3604

All in accordance with the plans and/or specifications, delivered F.O.B. DESTINATION, FREIGHT PREPAID AND ALLOWED, to CITY OF FRESNO, VARIOUS SITES, FRESNO, CALIFORNIA 93706.

Specifications for these items can be downloaded at the City's online website at:

www.fresno.gov. Doing Business (at the top of the screen), Bid Opportunities

Bids shall be submitted electronically through Planet Bids or by paper only.

NR 1. General Description

The City of Fresno is soliciting bids to purchase 40 ft. all electric buses for delivery as stated in SP 5.2 Delivery Schedule.

The units shall be an air-conditioned low floor battery electric transit coaches comprised of a single functional unit. They shall have seating, as further described and shall have doors, and floor configurations suitable for City passenger use. Vehicles shall be supplied with a wheelchair ramp at the entrance and wheelchair positions with restraints.

In all cases, materials must be new and furnished as specified. Where brand names or specific items are used in these specifications, consider the term "reviewed equal" to follow. Wherever such names appear, reviewed equals will be accepted only with the prior written concurrence from the City. All test data required within these specifications shall be submitted to the City prior to delivery of pilot vehicle unless specified otherwise.

The Contractor shall conform to these technical specifications and shall not omit any unit or component or both, part or detail to make these buses ready for service, even though such part or detail is not mentioned in these specifications. In absence of a specification, the Contractor shall adhere to its manufacturing standards. No changes or substitutions are permitted without the prior written consent of the City. This procurement will allow retirement of older buses and expansion of the revenue fleet. The City's overall objective for purchase, design, and operation of a new fleet of electric buses shall be to satisfy the following requirements:

- Safe and Reliable in Operation
- Economic to Purchase, Operate and Maintain
- Optimized Performance, Emissions and Fuel Consumption
- Full compliance with all applicable rules, regulations, and standards in place at the time of manufacturing.

This is a federally funded project. All proposers must comply with all FTA terms and conditions stated in section 4.

Completed Disadvantaged Business Enterprise (DBE) Utilization Form and Participation Schedule in Attachment G. Please note that there is a 0% DBE participation requirement for this project, but DBE reporting is still required. If a DBE is part of the Contractor's team then the percentage of DBE participation shall be recorded.

NR 2. Description of the Work to be Done

Specifically, the City is requesting the following types of vehicle(s):

- 40 Foot Low Floor Regular All-Electric Fixed Route Bus

NR 3. Vehicle Design

The 40 ft. all electric buses shall have a sleek, aerodynamic, modern, and fashionable design that is aesthetically appealing. A raised roof cap shall be designed to run the entire roof of the bus and conform to the contours of the body's sleek, aerodynamic, modern, and fashionable design of the bus. The raised roof cap shall mask the electrical, HVAC system, battery system, and any other roof mounted equipment of the bus. The raised roof cap shall flow seamlessly from the top of the windshield to the rear of the bus. The windows shall be hidden framed and mount flush with the exterior of the bus. All exterior panels shall have a smooth and seamless look with no visible fasteners. Exterior access doors shall be designed to be functional with a sleek and discrete look.

NR 4. Obtaining Bid Documents

The Bid Proposal forms and specifications may be obtained from the Office of the Purchasing Manager (phone 559 621-1332) or downloaded via the City's website: www.fresno.gov, Doing Business (at the top of the screen), Bid Opportunities.

NR 5. Bid Due Date and Submittal Requirements

Bids are to be submitted at the Office of the Purchasing Manager of the City of Fresno, 2600 Fresno Street, Room 2156, Fresno, CA 93721 prior to the opening at 3 p.m. on Tuesday, June, 26th, 2018, at which time they will be publicly opened and recorded.

All bids must be made on the bid forms provided by the Purchasing Manager and must be accompanied by a deposit in the amount of **FIFTEEN-THOUSAND DOLLARS (\$15,000)** in the form of a Cashier's or Certified Check, an irrevocable letter of credit, or a certificate of deposit, or a bidder's bond of a corporate surety, authorized by the California Insurance Commissioner to do business in the State of California, payable and acceptable to the City of Fresno. All deposits will be held until a Contract has been executed with the successful Proposer or all bids have been rejected.

The City of Fresno hereby notifies all Proposers that no person shall be excluded from participation in, denied any benefits of, or otherwise discriminated against in connection with the award and performance of any contract on the basis of race, religious creed, color, national origin, ancestry, physical disability, mental disability, medical condition, marital status, sex, age, sexual orientation or on any other basis prohibited by law.

NR 6. Pre-Bid Meeting Information

A Pre-Bid conference will be held at **11:00 a.m. on June, 11th, 2018**, at the Office of the Purchasing Manager, 2600 Fresno Street, Room 2156, Fresno, California. Prospective Proposers are encouraged to attend.

The meeting room is physically accessible. Services of an interpreter and additional accommodations such as assistive listening devices can be made available. Requests for accommodations should be

made at least five working days but no later than 48 hours prior to the scheduled meeting/event. Please contact the Procurement Specialist listed on the cover at 559-621-1332 or Alex.Nazaroff@fresno.gov or through the Questions and Answers field on Planet Bids.

The City reserves the right to reject any and all bids.

NR 7. Federal

This project is funded in part with financial assistance from the U.S. Department of Transportation, Federal Transit Administration (FTA). The successful proposer shall be knowledgeable of and in compliance with all applicable Federal Third Party Contract Clauses. The actual number of purchased will be based upon the overall availability of local and federal funds.

Applicable FTA Guidance

FTA Circular 4220.1F provides contracting guidance for recipients of federal assistance awarded by FTA when using that federal assistance to fund procurements or third party contracts. FTA also publishes a Best Practices Procurement Manual (BPPM) which is available on FTA's website. Additional procurement requirements can be found in the Uniform Administrative Requirements for Grants and Cooperative Agreements to State and Local Governments at 2 Code of Federal (CFR) 200.317-.326. Contracting and procurement staff should consult these authorities and guidance documents when procuring items funded by FTA.

The City will carry out applicable federal requirements in the award and administration of any contract award hereunder. This is a federal project funded in full or in part through the U.S. Department of Transportation, Federal Transit Administration (FTA).

Bidders are advised that, as required by federal law, the State of California has established a statewide overall DBE goal. City of Fresno federal-aid contracts are considered to be part of the statewide overall DBE goal and the City is required to report to the Federal Transit Administration (FTA) on DBE participation for all Federal-aid contracts each year so that attainment efforts may be evaluated.

SECTION 2: INSTRUCTIONS TO BIDDER

IP 1. General

BID PROPOSALS WILL BE CONSIDERED FOR AWARD ONLY IF THE BIDDER HAS COMPLIED WITH THE FOLLOWING:

Bid Proposals shall be submitted on the forms furnished by the Purchasing Manager, with all documents listed on the Bidder's Checklist, completely filled out, properly signed by the Bidder and delivered, under sealed cover, plainly marked:

PRODUCT PURCHASE CONTRACT FOR:
Two (2) 40' Low Floor Regular All-Electric Fixed Route Bus

BID FILE NUMBER: 3604

to the Office of the Purchasing Manager, 2600 Fresno Street, Room 2156, Fresno, California, 93721, or electronically filed utilizing Planet Bids prior to the date and time specified in the Notice Inviting Bids, when all bids will be publicly opened and recorded. Bids received at 3:00 p.m. or after will **not** be accepted. The time stamp in the Purchasing Division will be the official clock for documenting the time of filing. Electronically filed is defined as by means of electronic equipment or devices.

IP 2. Bidder's Deposit

A Bid Deposit has been made in accordance with IP 2.1 Bid Deposit. **A bid without a proper Bid Deposit will be automatically rejected and/or will not be read publicly at the bid opening.**

Note: Company Checks are NOT acceptable

IP 2.1 Bid Deposit

Bidders must submit a Bid Deposit, which may be provided separately, in the amount of **FIFTEEN-THOUSAND DOLLARS (\$15,000)** with their Bid Proposal. Such Bid Deposit shall be in the form of a certified cashier's check, an irrevocable letter of credit or a certificate of deposit payable to the City of Fresno, or a bidder's bond executed by a corporate surety, admitted by the California Insurance Commissioner to do business in California, payable and acceptable to the City of Fresno. Such Deposit shall be retained by the City of Fresno as a guarantee that the Bidder, if awarded all or part of the Contract, will within 15 calendar days (except in the event federal funding is applicable to this Contract, then 10 working days) from the date the Notice of Award is mailed to the Bidder, execute and return a Contract furnished by the City. No Bid Deposits will be returned to Bidders until either a Contract has been executed for all items awarded, or all bids have been rejected. Bid bonds will not be returned, except upon Bidder's written request. Copies of Bid Deposits may be submitted electronically, with the exception of a cashier's check, which must be brought to the Purchasing Manager's office and labeled accordingly with bid number.

Note: A bid without a proper deposit will automatically be rejected.

IP 2.2 Annual Bidders Bond

If the Bidder contemplates submitting bids from time to time during a period of one (1) year for the furnishing of certain materials, supplies or services to the City of Fresno, the Bidder may cover all such bids by a single Annual Bidder's Bond instead of a separate bond for each bid. If such an Annual Bidder's Bond is registered with the Purchasing Manager of the City of Fresno, and is currently valid, it shall be deemed to accompany each and every bid submitted, provided such bond is in a sufficient

amount to provide the required Deposit for all of the Bidder's bids then outstanding. It shall be stated upon the Bid Proposal that such an Annual Bidder's bond is registered with the Purchasing Manager of the City of Fresno.

IP 3. Submittal of Bid

Each Proposer shall carefully examine each and every term of this Request for Bid; and each Proposer shall judge all the circumstances and conditions affecting his/her bid. Failure on the part of any Proposer to make such examination and to investigate thoroughly shall not be grounds for any declaration that the Proposer did not understand the conditions of this Request for Bid.

The Proposer shall comply with any and all federal, state or local laws, now in effect or hereafter promulgated, which apply to the services and products herein specified.

Proposers will submit **an original and 5 of copies of their bid in a sealed envelope**, marked on the outside RFP No. **3604, Two (2) 40' Low Floor Regular All-Electric Fixed Route Bus** and will include the name of the Proposer and the date and time of bid submittal deadline. If bids submitted electronically, hard copies are not applicable.

This solicitation for bids does not commit the City of Fresno to enter into a Contract or to pay any costs incurred in the preparation of responses to the request. The City of Fresno reserves the right to accept or reject any bids, and to negotiate with any qualified source, or to cancel in part or in its entirety this Request for Bids. It may accept the bid that it considers to be in the interest of the City of Fresno, with or without negotiation.

The City reserves the right to waive any informality or minor irregularity when it is in the best interest of the City to do so, to negotiate for the modification of any bid with mutual consent of the Proposer, to re-advertise for bids if desired, and to accept the bid which in the judgment of the City, even though it does not offer the lowest cost, is nevertheless deemed to offer the best value for the public and City. Any bid which is incomplete, conditional, obscure, or which contains irregularities of any kind, may be cause for rejection.

IP 4. Contract Definitions

Attention of Bidders is especially directed to all provisions of the Contract Documents as defined in the GENERAL CONDITIONS.

IP 5. Questions, Clarifications and Concerns

The Specifications describing this project/purchase have been carefully prepared. **Any questions or concerns relating to these Specifications shall be directed in writing to the Designated Procurement Specialist of the Purchasing Unit (see cover page) and may be submitted electronically by utilizing the Questions and Answers field on Planet Bids.**

Questions will be accepted only up to 5 working days prior to the bid opening date to allow the City, if necessary, to issue an addendum to all bidders stating revisions, deletions, or additions to be made to the Specifications as a result of any questions. If questions arise after the deadline, please contact the designated Procurement Specialist, but the City will not guarantee a response.

The City will not be responsible for verbal responses made by parties other than the Purchasing Manager or her/his designee.

IP 6. Contacts with City Staff

Before an award is made, any contact with City staff, other than the Purchasing Manager or his/her designee(s), without prior written authorization is strictly prohibited and may render the Bidder

non-responsible.

IP 6.1 Regulated Communications in City Procurement Process Ordinance

The Regulated Communications in City Procurement Process Ordinance (Article 6, Chapter 4 of the Fresno Municipal Code) became effective May 7, 2004. With certain specified exceptions, the Ordinance provides that no Respondent, Bidder, Proposer (as the case may be) shall initiate, engage in, or continue any communication to or with any City elected official concerning or touching upon any matter which is the subject of this competitive procurement process.

Any Respondent, Bidder, Proposer or elected official (as the case may be) who initiates, engages in, continues in, or receives any regulated communication shall file the written disclosure required by the Regulated Communications in City Procurement Process Ordinance.

Any Respondent, Bidder, or Proposer violating the Regulated Communications in City Procurement Process Ordinance may be disqualified from participating in this procurement process and/or determined to be non-responsible. Additionally, the City may set aside the award of a contract, prior to its execution, to a party found to have violated the Ordinance.

Note: The full text of Fresno Municipal Code, Chapter 4, Article 6 may be viewed on the City's website at, www.fresno.gov. Under "Government"; "Fresno Municipal Code." Or view the Fresno Municipal Code directly at <http://www.municode.com/Resources/gateway.asp?sid=14478&sid=5>

IP 6. City Reviewed Equals

For equipment and material purchases, where brand name/model are specified, the City reserves the right to evaluate any product or type of equipment offered on the Bid Proposal and to determine acceptability as an "approved equal."

1. All Bid Proposals must be accompanied with pertinent information that provides sufficient technical data to evaluate the item(s) offered. The information may consist of manufacturer's literature, specifications, drawings (to scale), sketches (to proportion) performance data, etc., where same is necessary to completely describe the product.
2. The decision of acceptability as an "approved equal" shall be within the sole discretion of the City. If approval as an equal is denied by the City, Contractor shall provide one of the manufacturers/brands listed in the Specifications without change in the Contract price.

IP 7. Exceptions

Any exceptions taken at the time of or after bid submittal may render the bid nonresponsive. Attachments by Bidders which include legal terms and conditions that conflict with the GENERAL CONDITIONS may be considered an exception, and Bidder may, therefore, be considered nonresponsive.

IP 8. Bid Appeal Procedure

The City has an appeal procedure in place as adopted by the City Council on April, 29, 2003 in Resolution No. 2003-129. Any bidder wishing to file an appeal should refer to that Resolution. A copy of the Resolution may be obtained from the City Clerk's Office, 2600 Fresno Street, Fresno, CA 93721.

Once City staff has reviewed and evaluated the bid proposals received and has determined the lowest responsible Bidder for award, that determination will be posted on a public bulletin board outside the Purchasing Unit's Office and on the City's website www.fresno.gov, *Bid Opportunities, Anticipated Awards*, a minimum of 5 working days prior to Council action to award a Contract for the project/purchase. The bulletin board and website will generally be updated by Monday of each week,

no later than 5 p.m. It is the sole responsibility of interested bidders to seek this information from either of these sources.

Should bidders wish to appeal the staff determination, appeals must be received in writing within 5 working days from the time the determination is posted and conform to the requirements under Resolution No. 2003-129. "Working day" means a City of Fresno regular business day. In no event will appeals be accepted later than 5:00 p.m. on the day before Council is scheduled to take action on the Contract award. Appeals must be submitted to following:

City of Fresno Purchasing Unit
2600 Fresno Street, Room 2156
Fresno, CA 93721
Fax number (559) 457-1522

Letters of appeal must clearly state why it is felt the staff's determination of bid award is to someone other than the lowest responsive and responsible Bidder, or outside the procedural requirements for the submission and opening of bids.

Appeals not submitted within the stated time will not be honored and the City will proceed to award the Contract.

IP 9. Debarment

A Bidder who has been determined by the Council to be non-responsible may be debarred from bidding or proposing upon or being awarded any contract with the City or City of Fresno Successor Agency, or from being a subcontractor or supplier at any tier upon such contract, in accordance with the procedures in Resolution No. 2003-130 adopted by Council on April 29, 2003. The initial period of any such debarment shall not be less than one year or more than three years. A Bidder may request a hearing, in accordance with Resolution No. 2003-130, upon receipt of a notice of proposed debarment from the City Manager or his/her designee. A copy of the Resolution may be obtained from the City Clerk's Office, 2600 Fresno Street, Fresno, California 93721.

IP 10. ADA

Accessibility Requirements: Supplier warrants that it complies with California and federal disabilities laws and regulations; and the Services will conform to the accessibility requirements of WCAG 2.0AA. Supplier agrees to promptly respond to and resolve any complaint regarding accessibility of its Services. The City may require bidder to comply with these accessibility requirements if they are awarded a contract.

IP 11. ACH Payment Initiative-Electronic Payment

Contractor shall provide complete and accurate billing invoices in order to receive payment. Billing invoices submitted must contain all information and supporting documentation required by the contract. Payment for invoices submitted by the contractor shall only be rendered electronically unless payment by paper check is expressly authorized by the Controller, in the Controller's sole discretion, due to extenuating circumstances. Such electronic payment shall be made in accordance with ordinary City procedures and practices. The contractor shall comply with the Controller's procedures to authorize electronic payments. Contractor acknowledges that it will not receive payment on any invoices submitted under this Contract if it does not comply with the Controller's electronic payment procedures, except where the Controller has expressly authorized payment by paper check as set forth above.

IP 12. Bidder's Checklist

PRODUCT PURCHASE CONTRACT FOR:
Two (2) 40' Low Floor Regular All-Electric Fixed Route Bus

BID FILE NUMBER: 3604

SUBMIT THIS BIDDER'S CHECKLIST WITH YOUR BID DOCUMENTS. Bidders shall complete and submit all documents marked with an "X" in the "REQUIRED" column. Documents required on the checklist but not included may render your bid nonresponsive and ineligible for award. Bids received by the City by the scheduled bid opening time will be opened and publicly read but are subject to verification that all the required documents have been submitted. Copies of Bid Deposits may be submitted electronically and separate, with the exception of a cashier's check, which must be brought to the Purchasing Manager's office and labeled accordingly with bid number.

Bids shall be submitted in a three-ring binder, **one original and 5 copies.** (If submitted electronically, hard copies are not applicable). The total bid packet must be sealed and clearly marked on the outside **Bid File No. 3604 for Two (2) 40' Low Floor Regular All-Electric Fixed Route Bus.**

Proposers are requested to submit this Checklist and the following information, providing the content in the sequence shown below. If documentation provided is incomplete, the Proposer may be considered non-responsive and ineligible for award of a Contract.

REQUIRED

- 1. **COVER LETTER**, including company, address, contact name, phone and Fax number.
- 2. **BID DEPOSIT** attached to front of Bid in the form of:
 - Certified Check
 - Bidder's Bond
 - Cashier's Check
 - Irrevocable Ltr of Credit
 - Certificate of Deposit
 - Annual Bidder's Bond

***** (Note: Company Checks are NOT acceptable) *****
- 3. **BIDDER'S CHECKLIST** (p. 20)
- 4. **BID PROPOSAL PAGES** (p. 21)
- 5. **COMPLIANCE WITH TECHNICAL SPECIFICATIONS** (p. 61-179)
- 6. **COMPLIANCE WITH WARRANTY SPECIFICATIONS** (p. 180-187)
As required in Section 7: Warranty Requirements, any applicable manufacturer's Published Price List or website, and two copies of the manufacturer's descriptive literature and specifications or website, including a copy of the manufacturer's standard warranty.
- 7. **COMPLIANCE WITH QUALITY ASSURANCE** (p. 188-201)
- 8. **ADDENDA** - Signature page of all Addenda issued (p. 202), if applicable.
Addenda No. _____ to _____ (Enter numbers).

***** (Note: additional documents will vary) *****
- 9. **FEDERAL CERTIFICATIONS AND FORMS** (p. 203-210 complete/return attached forms)
- 10. **CITY CERTIFICATIONS AND FORMS** (p. 211-220 complete/return attached forms)
- 11. **SIGNATURE PAGES** (p. 215-216), including document to authorize individual to signs bid.
- 12. **ACH AUTHORIZATION AGREEMENT FORM** – Signature page of ACH payment. (p. 217)
- 13. **APPENDIXES AND EXHIBITS** (p. 236-252)

IP 13. Bid Proposal

PRODUCT PURCHASE CONTRACT FOR:
Two (2) 40' Low Floor Regular All-Electric Fixed Route Bus

BID FILE NUMBER: 3604

TO: THE PURCHASING MANAGER OF THE CITY OF FRESNO:

The undersigned Bidder hereby proposes to furnish to the City of Fresno, all in accordance with the specifications annexed hereto and made a part hereof, the following bid item(s), **to be delivered F.O.B. Destination, freight prepaid and allowed, to the jobsite as specified in the Special Conditions of these specifications**, at the prices set forth herein:

<u>Bid Item</u>	<u>Qty.</u>	<u>Description</u>	<u>Unit Price</u>	<u>Total Price</u>
1.	2	40' Low Floor Regular All-Electric Fixed Route Bus (per specifications herein)	\$ _____	\$ _____
2.	2	Shop Depot Chargers (per specifications herein)	\$ _____	\$ _____
3.	1	Spare Components and Parts Deliverables (per TS 8.7.2)	\$ _____	\$ _____
4.	1	Tooling and Equipment Deliverables (per TS 8.7.3)	\$ _____	\$ _____

SALES TAX (7.975%) \$ _____

TOTAL NET BID AMOUNT: \$ _____

The Total Amount of Bid is: _____ Dollars
 and _____ Cents.

The above amount shall include any and all applicable taxes.

The actual number of vehicles purchased will be based upon the overall availability of local and federal funds.

Completion of Bid Proposal Form to be Eligible for Award. Bidders must bid all bid items within a section (including any Alternates). The Bidder is non-responsive and ineligible for award in the event Bidder fails to initial this paragraph on the line provided and completely fill in the Bid Proposal Form including, without limitation, all dollar amounts and information called for on this Bid Proposal Form. By his/her initials to the right hereof, Bidder represents he/she has read and understands the consequences of not completely filling in this Bid Proposal Form.

Initial

IP 14. Contract Quantities

The City reserves the right to increase or decrease quantities in accordance with available funds as appropriated by the City Council. If the City Council has not appropriated funds or sufficient funds are not available to complete the purchase, the City reserves the right to decrease quantities to stay within the budget limitations.

IP 15. Addenda

The City makes a concentrated effort to ensure any addenda issued relating to these specifications are distributed to all interested parties. It shall be the Bidder's responsibility to inquire as to whether any addenda to the Specifications have been issued. Upon issuance by the City, all Addenda are part of the Bid Proposal. Signing the Bid Proposal on the signature page thereof shall also constitute signature on all Addenda.

IP 16. Public Records

The bids received shall become the property of the City of Fresno and are subject to public disclosure. Those parts of a bid which are defined by the Proposer as business or trade secrets as that term is defined in California Evidence Code, Section 3426.1, and are reasonably marked "Trade Secrets", "Confidential", or "Proprietary", and placed in a separate envelope shall only be disclosed to the public if such disclosure is required or permitted under the California Public Records Act or otherwise by law. Proposers who indiscriminately and without justification identify most, or all, of their bid as exempt from disclosure may be deemed non-responsive. Bids, excluding confidential information, will be available for review after posting of staff recommendation.

IP 17. Contract Documents

The proposer shall submit the required contract documents in a form acceptable to the Purchasing Division 2600 Fresno ST. Room 2156 – Fresno, Ca. 93721 within 15 calendar days (except in the event in the event federal funding is applicable to the Contract, then 10 working days) from the Notice of Award of bid. Failure to provide said documents within the designated period shall be sufficient cause to find the bid non-responsive and move to award to the next proposer offering the next best value to the City.

IP 18. Precedence of Bid Prices

In the event of discrepancies between the bid total, summaries of totals and unit price extensions, the unit price correctly extended will control over the summaries of totals, and the summaries of totals correctly added will control over the total, whether the summaries of totals are extended unit prices or lump sums.

IP 19. Right to Reject Any and All Bids

The City reserves the right to reject any and all bids.

IP 20. Time Period to Award/Reject Bids

The undersigned Bidder agrees that the City may have **ONE-HUNDRED and TWENTY (120) DAYS** from the date bids are opened to accept or reject this Bid Proposal. It is further understood that if the Bidder to whom any award is made fails to enter into a Contract as provided in the Specifications, award may be made to the next lowest responsive and responsible Bidder, who shall be bound to perform as if he/she had received the award in the first instance. No Bid Proposal may be withdrawn prior to award within that time.

IP 21. Award of Contract

When bids are submitted to the Council, the award will be made to the lowest responsive and responsible bidder, subject to the right to reject any and all bids, pursuant to Fresno Municipal Code section 4-102.

IP 22. Notification of Staff Determination

Once the City has reviewed and evaluated the bids received and has determined for award the responsible bid that provides the best value to the City, that determination will be posted on a public bulletin board outside the Purchasing Units Office and the City's website www.fresno.gov, reference link "For Business" (right hand side of screen), "Bid Opportunities," and "Anticipated Award." The bulletin board and website will generally be updated by Monday of each week, no later than 5 p.m. It is the sole responsibility of interested Proposers to seek this information from either of these sources.

For those Proposers that have concerns or rebuttal of any determination of non-responsiveness or non-responsibility about the Staff Determination, they will be given an opportunity to submit, in writing, within [5] days to the Purchasing Manager any concerns with the RFP process or Staff Determination. Such writing will be taken under consideration by the City Manager and may be acted upon within [5] days. If no action is taken within such [5] days, then there shall be no change in Staff Determination. The exercise of Proposer of its right to submit its written concerns shall be a condition precedent to seeking judicial review of any award of a contract hereunder.

IP 23. Minor Irregularities

The City of Fresno reserves the right to waive any informality or minor irregularity that does not have a monetary consideration when it is in the best interest of the public and of the City to do so. A discrepancy that offers a Bidder an unfair advantage will cause the bid to be nonresponsive.

IP 24. Tiebreaker

In the event a tiebreaker is needed to establish the lowest responsive and responsible Bidder, the City shall, unless otherwise agreed upon by all participating parties, utilize a coin toss as a tiebreaker to be administered by a third party chosen by mutual consent of the participants. Such coin toss shall take place within 7 working days from the date of bid opening. If the City determines that a tiebreaker is necessary, each applicable Bidder agrees to participate or to indemnify the City in any litigation resulting from the utilization of the tiebreaker. If a Bidder refuses to timely participate, the City shall conduct the coin toss in a manner determined by the City to be fair to all and the results of such coin toss shall be final.

IP 25. Contract Documents

(To be filed after award by successful Bidder)

SECTION 3: GENERAL CONDITIONS

CITY OF FRESNO SPECIFICATIONS

PRODUCT PURCHASE CONTRACT FOR: Two (2) 40' Low Floor Regular All-Electric Fixed Route Bus

BID FILE NUMBER: 3604

GC 1. Definitions

Wherever used in the Specifications, including the Instructions to Bidders and the Bid Proposal, or any of the Contract Documents, the following words shall have the meaning herein given, unless the context requires a different meaning.

- (a) "Bidder" and "Proposer" shall mean and refer to each person or other entity submitting a Bid, whether or not such person or entity shall become a Seller by virtue of award of a Contract by the City.
- (b) "City," "Buyer," "Owner," "Vendee" and "City of Fresno" shall each mean and refer to the City of Fresno, California.
- (c) "Contract", "Contract Documents", "Bid", and "Bid Documents" shall each mean and refer to these Specifications, including the Instructions to Bidders, the Bid and any addenda thereto, the Agreement and other standard Specifications, City's Specifications and other papers and documents incorporated by reference into or otherwise referred to in any of the foregoing documents, whether or not attached thereto.
- (d) "Contractor," "Seller," "Supplier" and "Contractor" shall each mean and refer to each person or other entity awarded a Contract hereunder and named or to be named in the Agreement with the City to furnish the goods or services, or both, to be furnished under the Contract.
- (e) "Council" and "City Council" shall each mean and refer to the Council of the City.
- (f) "Goods" and "Merchandise" shall each mean and refer to the equipment, material, article, supply or thing to be furnished by the Seller under the Contract.
- (g) "Purchasing Manager" shall mean and refer to the Purchasing Manager of the City.
- (h) "Specifications" shall mean and refer to all of the Contract Documents.
- (i) "Working day" shall mean and refer to City regular business day.

GC 2. Products Liability Insurance

If these Specifications are for equipment with moving parts, the Contractor shall maintain, and provide the City of Fresno with verification of, manufacturer's products liability insurance policy in excess of \$1,000,000 on said Bid Item(s) equipment.

GC 3. Indemnification

To the furthest extent allowed by law, including California Civil Code section 2782 (if applicable), Contractor shall indemnify, hold harmless and defend City and each of its officers, officials, employees, agents and volunteers from any and all loss, liability, fines, penalties, forfeitures, costs and damages (whether in Contract, tort or strict liability, including, but not limited to personal injury, death at any time and property damage) incurred by City, Contractor or any other person, and from any and all claims, demands and actions in law or equity (including attorney's fees and litigation expenses), arising or

alleged to have arisen directly or indirectly out of performance of this Contract. Contractor's obligations under the preceding sentence shall apply regardless of whether the City or any of its officers, officials, employees, agents or volunteers are passively negligent, but shall not apply to any loss, liability, fines, penalties, forfeitures, costs or damages caused by the active or sole negligence, or by the willful misconduct, of the City or any of its officers, officials, employees, agents or volunteers.

If Contractor should subcontract all or any portion of the work to be performed under this Contract, Contractor shall require each subcontractor to indemnify, hold harmless and defend City and each of its officers, officials, employees, agents and volunteers in accordance with the terms of the preceding paragraph.

This section shall survive termination or expiration of this Contract.

GC 4. Federal Immigration Reform and Control Act Of 1986

As a material part of any contract for a City of Fresno project, every Contractor who has employees who will work on a City of Fresno project, is required to comply with all of the provisions of the Federal Immigration Reform and Control Act of 1986 (P.L. 99-603, 100 Stat. 3359). This requirement includes compliance with all of the employee documentation provisions. Furthermore, the Contractor will make any employee documentation required to comply with the Act immediately available to the City upon its request for each individual employee working on a City of Fresno project.

GC 5. Workmanship Guaranty

The workmanship of the goods or services provided to the City by the Contractor will be in accordance with generally accepted standards.

GC 6. Warranty

For the purchase of equipment and material, the Contractor, unless otherwise provided in the Specifications, shall guarantee all items furnished in accordance with the standard guarantee offered by the manufacturer to cities and consumers of the product. The Contractor shall be responsible for all warranty costs, including the transportation costs to and from the repair station.

GC 7. Precedence Of Contract Documents

The order of precedence of documents shall be: (1) Rules and Regulations of Federal Agencies relating to the source of funds for this purchase; (2) Supplemental Agreements, Change Orders, or Contract the one dated later having precedence over another dated earlier; (3) Special Conditions; (4) General Conditions; (5) Technical Specifications.

Whenever any conflict appears in any portion of the Contract, it shall be resolved by application of the order of precedence.

GC 8. Contract Documents

Upon award of the Contract, the Contractor shall execute and submit all required documents (which will include the "Contract," a sample of which is included in these Specifications on page 2019-220) to the Purchasing Manager, 2600 Fresno Street, Room 2156, Fresno, California 93721 in a form acceptable to the City of Fresno within 15 calendar days (except in the event federal funding is applicable to this Contract, then 10 working days) from the date of Notice of Award. Failure to provide said documents within the designated period shall be sufficient cause to forfeit the Contractor's bid deposit and initiate a departmental recommendation to the Council to award the Contract to the next lowest responsive and responsible Bidder.

GC 9. Assignment of Payment

Contractor hereby agrees it will not assign the payment of any monies due it from the City under the terms of this Contract to any other individual(s), corporation(s) or entity(ies). The City retains the right to pay any and all monies due Contractor directly to Contractor.

GC 10. Patents

For the purchase of equipment and material, the Contractor shall hold the City of Fresno, its officers and employees, harmless from any and all liability for damages arising out of the use of any patented material, equipment, device or process incorporated into or made a part of or required by the manufacturer's specifications to be used on or in connection with the material, equipment or supplies purchased by the City pursuant to these Specifications, and Contractor agrees, by submission of a bid hereunder, to defend the City, at Contractor's sole expense, in any action or suit for damages or injunctive relief on account of any allegedly unauthorized use of or infringement of patent rights on any patented material, equipment, device or process, if the City is named as a defendant in any such action or suit.

GC 11. OSHA Compliance

For the purchase of equipment and material, the items covered by this Contract must conform with the Safety Orders of the State of California, Division of Industrial Safety, pursuant to the California Occupational Safety and Health Act, and the Federal Standards established by the Occupational Safety and Health Act of 1970, and their present and future amendments during the term of this Contract. In the event of a conflict between such Safety Orders and Federal Standards, the items shall conform to the respective Order or Standard which is more restrictive.

GC 12. Recycling Program

In the event Contractor maintains an office or operates a facility(ies), or is required herein to maintain or operate same, within the incorporated limits of the City of Fresno, Contractor at its sole cost and expense shall:

- (i) Immediately establish and maintain a viable and ongoing recycling program, approved by City's Solid Waste Management Division, for each office and facility. Literature describing City recycling programs is available from City's Solid Waste Management Division and by calling City of Fresno Recycling Hotline at (559) 621-1111.
- (ii) Immediately contact City's Solid Waste Management Division at (559) 621-1452 and schedule a free waste audit, and cooperate with such Division in their conduct of the audit for each office and facility.
- (iii) Cooperate with and demonstrate to the satisfaction of City's Solid Waste Management Division the establishment of the recycling program in paragraph (i) above and the ongoing maintenance thereof.

GC 13. Sustainability

The City recognizes that being sustainable (environmentally, economically and socially responsible) involves everyone, both internal and external to the City. The City expects its Contractors to have their own sustainability policies and programs in place and to provide services in line with the principles established therein. Implementation of sustainable practices may include maximizing the use of environmentally and socially responsible materials and services, utilizing energy-efficient and non-polluting vehicles, equipment and processes, and ensuring employee awareness of sustainability initiatives.

The City has a sustainability policy that includes the responsibility to make sure all of its Contractors are

informed of this policy. The Contractor will provide the City with a statement indicating that responsible parties have read and understand the City's sustainability policies and that it agrees to use reasonable efforts to conduct its work and operations in a manner that is consistent with them. In addition the Contractor will provide the City with a copy of its corporate sustainability policy to the contract program, processes, and procedures for review (CDRL).

GC 14. Delivery and Extensions

Unless otherwise provided in the Specifications, delivery shall be made F.O.B. the specified place of delivery within the City of Fresno or environs.

If Contractor is delayed making delivery by any conditions or events beyond the reasonable control of Contractor and without its fault or negligence such as acts of God or the public enemy, acts of City in its contractual capacity or otherwise, illegal strikes, boycotts or like illegal obstructive action by employee or labor organizations, illegal general lockouts or other defensive action by employers, whether general or by organizations of employers, fires, floods, epidemics, quarantine restrictions, and delays of common carriers; Contractor shall have no claim for damages against City for any such cause of delay, but shall in such cases be entitled to such extension of time as shall reasonably compensate for actual loss of time occasioned thereby, upon application to said City Manager for such extension; provided, that no such extension of time shall be granted unless Contractor shall have notified the Purchasing Manager in writing, of the condition or event which is expected to cause a delay in delivery and the actual or estimated number of days of delay anticipated on account thereof, within one week after the commencement or occurrence of the condition or event. Contractor shall remedy such occurrence with all reasonable dispatch, and shall promptly give written notice to the Purchasing Manager of the cessation of such occurrence. The decision of said City Manager as to the number of additional days, if any, to be allowed for completion of delivery on account of such condition or event, shall be given in writing to Contractor.

GC 15. Contract Documents

Upon award of the Contract, the Contractor shall execute and submit all required documents (which will include the "Product Requirements Contract," a sample of which is included in these Specifications on page 219-220) to the Purchasing Manager, 2600 Fresno Street, Room 2156, Fresno, California 93721 in a form acceptable to the City of Fresno within 15 calendar days (except in the event federal funding is applicable to this Contract, then 10 working days) from the date of Notice of Award. Failure to provide said documents within the designated period shall be sufficient cause to forfeit the Contractor's Bid deposit and initiate a departmental recommendation to the Council to award the Contract to the next lowest responsive and responsible Bidder.

GC 16. Payment

Unless otherwise provided in the Specifications, payment of the Contract price shall be made by City to Contractor in lawful money of the United States by warrant of City issued and delivered to Contractor in the ordinary course of City business promptly after completion of delivery of the specified item(s) and their acceptance by City.

GC 17. Funding

This Contract is contingent on the appropriation of funds by City. Should funds not be appropriated, this Contract may be terminated by City upon prior written notice to Contractor notwithstanding any other provision of these General Conditions.

GC 18. Termination For Convenience

The City reserves the right to terminate this Contract upon 60 calendar days' prior written notice to the

Contractor. In the event of such termination, the Contractor shall be paid for satisfactory service performed to the date of termination.

GC 19. Termination For Non-Performance

If Contractor shall (i) materially breach any of its obligations under this Contract (including, without limitation, the failure to meet quality standards or to complete delivery, within the time specified herein, of all or any part of the materials, equipment, supplies or services to be provided under the Contract), and (iii) fail to commence and diligently pursue reasonable efforts to cure such breach within 5 calendar days after written notice by the City specifically describing the breach; the City Manager or his/her designee, acting for and on behalf of the City, may at any time after the expiration of the time for delivery, terminate the Contract as to the whole thereof, or in the event partial delivery has been made and accepted, as to such items or service to be furnished which have not been delivered or accepted prior to such termination. Such termination shall be effective upon receipt by Contractor of written notice of termination from said City Manager or his/her designee, which notice shall be deemed to have been received by Contractor, if mailed, within forty-eight hours to Contractor's address as contained in the Contractor's Bid Proposal or, if personally delivered, upon the delivery thereof to Contractor, the authorized representative of Contractor, or to the Contractor's said address.

The Contractor may terminate this Contract if City materially breaches any of its obligations under this Contract and fails to commence and diligently pursue reasonable efforts to cure such breach within 30 calendar days after written notice by the Contractor specifically describing the breach. Such termination shall be effective upon receipt by City of written notice of termination from Contractor, which notice shall be deemed to have been received by City, if mailed, within forty-eight hours to City's address as contained on the signature page of the Contract or, if personally delivered, upon the delivery thereof to the authorized representative of City or to City's said address.

GC 20. Termination by City for Non-Appropriation

In the event of non-appropriation relating to the Contract, City shall have the right to terminate the Contract at the end of any fiscal year of City, in the manner and subject to the terms specified in this paragraph. City shall endeavor to give written notice of such termination not less than sixty (60) days prior to the end of such fiscal year, and shall notify Contractor of any anticipated termination. For purposes of this paragraph, "fiscal year" shall mean the twelve month fiscal period of City which commences on July 1 in every year and ends on the following June 30. For purposes of this paragraph, "non-appropriation" shall mean the failure of the City or City's governing body to appropriate money for any fiscal year of City sufficient for the continued performance of the Contract by City.

GC 21. Independent Contractor

In the furnishing of the services provided for herein, the Contractor is acting as an independent contractor. Neither the Contractor, nor any of its officers, associates, agents or employees shall be deemed an employee, joint venturer, partner or agent of the City for any purpose. However, the City shall retain the right to verify that the Contractor is performing its respective obligations in accordance with the terms of the Contract.

Because of its status as an independent contractor, Contractor and its officers, agents and employees shall have absolutely no right to employment rights and benefits available to City employees. Contractor shall be solely liable and responsible for all payroll and tax withholding and for providing to, or on behalf of, its employees all employee benefits including, without limitation, health, welfare and retirement benefits. In addition, together with its other obligations under this Agreement, Contractor shall be solely responsible, indemnify, defend and save City harmless from all matters relating to employment and tax withholding for and payment of Contractor's employees, including, without limitation, (i) compliance with Social Security and unemployment insurance withholding, payment of workers compensation benefits, and all other laws and regulations governing matters of employee

withholding, taxes and payment; and (ii) any claim of right or interest in City employment benefits, entitlements, programs and/or funds offered employees of City whether arising by reason of any common law, de facto, leased, or co- employee rights or other theory. It is acknowledged that during the term of this Agreement, Contractor may be providing services to others unrelated to City or to this Agreement.

GC 22. Notices

Except as otherwise expressly provided in the Specifications, any notice required or intended to be given to either party under the terms of this Contract shall be in writing and shall be deemed to be duly given if delivered personally or sent by United States registered or certified mail, with postage prepaid, return receipt requested, addressed to the party to which notice is to be given at the party's address set forth on the signature page of the Bid Proposal in the case of the Contractor and at the address set forth on the signature page of the Contract in the case of the City, or at such other address as the parties may from time to time designate by written notice. Notices served by United States mail in the manner above described shall be deemed sufficiently served or given at the time of the mailing thereof.

GC 23. Binding

Subject to the following section, once this Contract is signed by all parties, it shall be binding upon, and shall inure to the benefit of, all parties, and each parties' respective heirs, successors, assigns, transferees, agents, servants, employees and representatives.

GC 24. Assignment

The Contract is personal to the Contractor and there shall be no assignment, transfer, sale, or subcontracting by the Contractor of its rights or obligations under the Contract without the prior written approval of the City. Any attempted assignment, transfer, sale or subcontracting by the Contractor, its successors or assigns, shall be null and void unless approved in writing by the City.

GC 25. Compliance with Laws and Regulations

The Contractor shall at all times comply with all applicable laws, regulations, policies, procedures and directives (together, the "Law"), including without limitation, FTA regulations, policies, procedures and directives, including those listed directly or by reference in the agreement between the City and FTA that funds any part of this Contract, as they may be amended or promulgated from time to time during the term of this Contract. Contractor's failure to so comply shall constitute a material breach of this Contract.

GC 26. Changes of Law

Changes of Law that becomes effective after the Bid Due Date may result in price changes. If a price adjustment is indicated, either upward or downward, it shall be negotiated between the City and the Contractor, and the final Contract price will be adjusted upward or downward to reflect such changes in Law. Such price adjustment may be audited, where required.

GC 27. Governing Law and Choice of Forum

This Contract shall be governed by the laws of California without regard to conflict of law rules. The Contractor consents to the jurisdiction of the identified state, County of Fresno.

GC 28. Waiver

The waiver by either party of a breach by the other of any provision of this Contract shall not constitute a continuing waiver or a waiver of any subsequent breach of either the same or a different provision of this Contract. No provisions of this Contract may be waived unless in writing and signed by all parties

to this Contract. Waiver of any one provision herein shall not be deemed to be a waiver of any other provision herein.

GC 29. Headings

The section headings in this Contract are for convenience and reference only and shall not be construed or held in any way to explain, modify or add to the interpretation or meaning of the provisions of this Contract.

GC 30. Severability

The provisions of this Contract are severable. The invalidity or unenforceability of any one provision in this Contract shall not affect the other provisions.

GC 31. Interpretation

The parties acknowledge that this Contract in its final form is the result of the combined efforts of the parties and that, should any provision of this Contract be found to be ambiguous in any way, such ambiguity shall not be resolved by construing this Contract in favor of or against either party, but rather by construing the terms in accordance with their generally accepted meaning.

GC 32. Attorney's Fees

If either party is required to commence any proceeding or legal action to enforce or interpret any term, covenant or condition of the Contract, the prevailing party in such proceeding or action shall be entitled to recover from the other party its reasonable attorney's fees and legal expenses.

GC 33. Exhibits

Each exhibit and attachment referenced in this Contract is, by the reference, incorporated into and made a part of this Contract.

GC 34. Cumulative Remedies

No remedy or election hereunder shall be deemed exclusive but shall, wherever possible, be cumulative with all other remedies at law or in equity.

GC 35. No Third Party Beneficiaries

The rights, interests, duties and obligations defined within this Contract are intended for the specific parties hereto as identified in the preamble of this Contract. Notwithstanding anything stated to the contrary in this Contract, it is not intended that any rights or interests in this Contract benefit or flow to the interest of any third parties other than expressly identified within this section. The parties do intend that in the event that the State of California is funding the purchase hereunder, that the State of California be a third party beneficiary under this Contract and all rights, interest and benefits of this Contract accrue to the State.

GC 36. Funding

This Contract is contingent on the appropriation of funds by City. Should funds not be appropriated, this Contract may be terminated by City upon prior written notice to Contractor notwithstanding any other provision of these General Conditions.

GC 37. Governing Law and Venue

The Contract shall be governed by, and construed and enforced in accordance with, the laws of the State of California, excluding, however, any conflict of laws rule which would apply the law of another

jurisdiction. Venue for purposes of the filing of any action regarding the enforcement or interpretation of the Contract and any rights and duties hereunder shall be Fresno County, California.

GC 38. Extent of Contract

Each party acknowledges that they have read and fully understand the contents of this Contract. This Contract represents the entire and integrated agreement between the parties with respect to the subject matter hereof and supersedes all prior negotiations, representations or agreements, either written or oral.

GC 39. Modifications and Change Orders

This Contract may be modified only by written instrument duly authorized and executed by both City and Contractor in accordance with City's current applicable contract change order resolution, as may be revised. The City reserves the right to add, modify or delete items from the Contract including, without limitation, the Special Conditions and Technical Specifications. Any such changes shall be made only by means of a formal change order signed by both the City and the Contractor.

GC 40. Alteration of Terms

No alterations or variations of the terms of this Contract shall be valid unless made in writing and signed by both parties.

GC 41. Contract Changes

No changes or modifications to the Contract shall be made unless agreed to and signed by both parties. No prior, current or post award verbal agreement or agreements with any officer, agent or employee of the City shall affect or modify any terms or obligations of these Specifications or any Contract resulting from this procurement.

GC 42. Amendments

The City of Fresno reserves the right to add, modify, or delete items from the Contract including Special Conditions or Scope of Work. Any changes shall be made only by means of a formal amendment signed by both the City and Contractor.

GC 43. DBE Requirements for Transit Vehicle Manufacturers

Pursuant to Title 49, Code of Federal Regulations, Part 26.49, a Bidder, as a condition of being authorized to respond to this solicitation, must certify by completing the form DBE Approval Certification that it has on file with the Federal Transportation Administration (FTA) an approved or not disapproved annual disadvantaged business enterprise (DBE) subcontracting participation goal.

GC 44. Buy America Certification

This Contract is subject to the "Buy America" requirements of 49 United States Code (USC) §5323(j) and 49 Code of Federal Regulations (CFR) Part 661, as may be amended from time to time, and applicable federal regulations. Prospective Bidders' attention is directed to 49 CFR §661.11, "Rolling Stock Procurements." Prospective Bidders have the responsibility to comply with the cited and any governing statutes and regulations, including official interpretations.

A Bidder shall submit to the City the appropriate Buy America certification, included in this document, with all offers on FTA-funded contracts. Bids that are not accompanied by a properly completed Buy America certification are subject to the provisions of 49 CFR 661.13 and will be rejected as nonresponsive. The Bidder shall submit proof of Buy America compliance and supply a certificate of compliance with each bus delivered to the City under this Contract. The City will conduct a Pre-Award

audit of the Contractor's compliance plan for technical and Buy America compliance, as well as a Pre-Delivery and Post-Delivery audit to verify compliance.

The two signature blocks on the Buy America certificate are mutually exclusive. Bidders shall sign only one signature block on the certificate. Signing both signature blocks will make the Bid nonresponsive. A false certification is a criminal act in violation of 18 USC §1001.

A Bidder who has submitted an incomplete Buy America certificate or an incorrect certificate of noncompliance through inadvertent or clerical error (but not including failure to sign the certificate, submission of certificates of both compliance and noncompliance, or failure to submit any certification), may submit to the FTA Chief Counsel within ten (10) days of Bid opening a written explanation of the circumstances surrounding the submission of the incomplete or incorrect certification in accordance with 28 USC §1746, sworn under penalty of perjury, stating that the submission resulted from inadvertent or clerical error. The Bidder will also submit evidence of intent, such as information about the origin of the product, invoices, or other working documents. The Bidder will simultaneously send a copy of this information to the City.

The FTA Chief Counsel may request additional information from the Bidder, if necessary. The City may not make Contract award until the FTA Chief Counsel issues his or her determination, except as provided in 49 CFR Part 661.15(m).

Certification based on ignorance of proper application of the Buy America requirements is not an inadvertent or clerical error.

A waiver from the Buy America provisions maybe sought by the City from the FTA for the proposed awardee, if the grounds for a waiver exist. All Bidders seeking a waiver must submit to the City a timely request in writing, which shall include the facts and justification to support the granting of the waiver. Such waiver from the Buy America provisions may be granted if the FTA determines the following:

1. Their application would be inconsistent with the public interest;
2. Materials are not produced in the United States in sufficient and reasonably available quantities and of a satisfactory quality; or
3. Inclusion of domestic material will increase the cost of the overall Contract by more than 25 percent.

Any party may petition the FTA to investigate a successful Bidder's compliance with the Buy America certification. The procedures are set out in 49 CFR Part 661.15. If the FTA determines that the evidence indicates noncompliance, the FTA will require the City to initiate an investigation. The successful Bidder has the burden of proof to establish compliance with its certification. If the successful Bidder fails to so demonstrate compliance, then the successful Bidder will be required to substitute sufficient domestic materials without revision of the original Contract terms. Failure to do so will be a breach of the Contract and may lead to the initiation of debarment proceedings under 49 CFR Part 29.

GC 45. FTA Review

After such administrative remedies have been exhausted, an interested party may file a protest with the Federal Transit Administration of the U.S. Department of Transportation pursuant to the procedures provided in the FTA C 4220.1F or its successor within five (5) working days of the date when the protester has received actual or constructive notice of the recipient's final decision. FTA review is limited to the alleged failure of the City to have written protest procedures, the alleged failure of the City to follow those procedures, the alleged failure of the City to review a protest or the alleged violation of federal law or regulation.

GC 46. Materials and Workmanship

The Contractor shall be responsible for all materials and workmanship in the construction of the bus and all accessories used, whether the same are manufactured by the Contractor or purchased from a Supplier. This provision excludes any equipment leased or supplied by the City, except insofar as such equipment is damaged by the failure of a part or component for which the Contractor is responsible, or except insofar as the damage to such equipment is caused by the Contractor during the manufacture of the buses.

Body materials shall be selected and the body fabricated to reduce maintenance, extend durability, and provide consistency of appearance throughout the service life of the bus. Detailing shall be kept simple; add-on devices and trim, where necessary, shall be minimized and integrated into the basic design.

GC 47. Conformance with Specifications and Drawings

Materials furnished and Work performed by the Contractor shall conform to the requirements of the Technical Specifications and other Contract documents. Notwithstanding the provision of drawings, technical specifications or other data by the City, the Contractor shall have the responsibility of supplying all parts, materials, details, and any units required to make the bus complete and ready for service even though such details may not be specifically mentioned in the drawings and specifications. Items that are installed by the City shall not be the responsibility of the Contractor unless they are included in this Contract. No substitution or change is permitted without the prior written consent of the City.

Omissions from the Contract specifications, or the inaccurate description of details of Work that are manifestly necessary to carry out the intent of the Contract specifications, or that are customarily performed, shall not relieve the Contractor from performing such omitted Work or inaccurately described details of the Work, and they shall be performed as if fully and correctly set forth and described.

GC 48. Inspection, Testing and Acceptance

GC 48.1 General

The City's Representative shall at all times have access to the Work, the Contractor and, through the Contractor, its Suppliers. The Contractor and its Suppliers shall furnish every reasonable facility for ascertaining that the materials and the workmanship are in accordance with the requirements of the Contract Documents. All Work done shall be subject to the City Representative's inspection and approval in accordance with the approved Work products developed as a result of the Contract Documents.

The Pre-Delivery Tests and inspections shall be performed at the Contractor's plant; they shall be performed in accordance with the procedures defined in "Section 8: Quality Assurance"; and they may be witnessed by the resident inspector. When a bus passes these tests and inspections, the resident inspector shall authorize release of the bus.

Within thirty (30) calendar days after arrival at the designated point of delivery, the bus shall undergo the City tests defined in "Post-Delivery Tests." If the bus passes these tests or if the City does not notify the Contractor of non-acceptance within 15 calendar days after delivery, then acceptance of the bus by the City occurs on the 30th day after delivery. If the bus fails these tests, it shall not be accepted until the repair procedures defined in "Repairs after Non-Acceptance" have been carried out and the bus retested until it passes. Acceptance occurs earlier if the City notifies the Contractor of early acceptance or places the bus in revenue service.

GC 48.2 Risk of Loss

The City shall assume risk of loss of the bus upon delivery, as defined in “Bus Delivery.” Prior to this delivery, the Contractor shall have risk of loss of the bus, including any damages sustained during the delivery regardless of the status of title or any payments related to the bus. Operators shall keep a maintenance log enroute, and it shall be delivered to the City with the bus. If the bus is released back to the Contractor for any reason, then the Contractor has the risk of loss upon such release.

GC 49. Title and Warranty of Title

Adequate documents for registering the bus in City of Fresno – Department of Transportation/FAX shall be provided to the City not less than 10 business days before delivery to the City. Upon acceptance of each bus, the Contractor warrants that the title shall pass to the City free and clear of all encumbrances.

Each unit shall be registered as follows:

City of Fresno
Department of Transportation/FAX
2223 "G" St.
Fresno, CA 93706

GC 50. Intellectual Property Warranty

The City shall advise the Contractor of any impending patent suit related to this Contract against the City and provide all information available. The Contractor shall defend any suit or proceeding brought against the City based on a claim that any equipment, or any part thereof, furnished under this Contract constitutes an infringement of any patent, and the Contractor shall pay all damages and costs awarded therein, excluding incidental and consequential damages against the City. In case said equipment, or any part thereof, is in such suit held to constitute infringement and use of said equipment or parts is enjoined, the Contractor shall, at its own expense and at its option, either procure for the City the right to continue using said equipment or part, or replace same with non-infringing equipment, or modify it so it becomes non-infringing.

The Contractor’s obligations under this section are discharged and the City shall hold the Contractor harmless with respect to the equipment or part if it was specified by the City and all requests for substitutes were rejected, and the Contractor advised the City under “Questions, Clarifications and Omissions” of a potential infringement, in which case the Contractor shall be held harmless.

GC 51. Data Rights

GC 51.1 Proprietary Rights/Rights in Data

The term “subject data” used in this clause means recorded information, whether or not copyrighted, that is delivered or specified to be delivered under the Contract. It includes the proprietary rights of the following:

- Shop drawings and working drawings
- Technical data including manuals or instruction materials, computer or microprocessor software
- Patented materials, equipment, devices or processes
- License requirements

The City shall protect proprietary information provided by the Contractor to the fullest extent of the law. The Contractor shall grant a non-exclusive license to allow the City to utilize such information in order to maintain the vehicles. In the event that the Contractor no longer provides the information, the City

has the right to reverse engineer patented parts and software.

The City reserves a royalty-free, non-exclusive and irrevocable license to reproduce, publish or otherwise use, and to authorize others to use, the following subject data for its purposes: (1) any subject data required to be developed and first produced in the performance of the Contract and specifically paid for as such under the Contract, whether or not a copyright has been obtained; and (2) any rights of copyright to which the Contractor, Subcontractor or Supplier purchases ownership for the purpose of performance of the Contract and specifically paid for as such under the Contract. The Contractor agrees to include the requirements of this clause, modified as necessary to identify the affected parties, in each subcontract and supply order placed under the Contract.

GC 51.2 Access to Onboard Operational Data

The City grants to the Contractor the right to inspect, examine, download, and otherwise obtain any information or data available from components provided by the Contractor, including, but not limited to, any electronic control modules or other data-collection devices, to the extent necessary to enable the Contractor to perform reliability maintenance analysis, corrective action and/or other engineering type Work for the bus. This right expressly excludes access to information or data collected on any equipment not provided and installed by the Contractor.

GC 51.3 Maintenance of Records; Access by City; Right to Audit Records

In accordance with 49 CFR § 18.36(i), 49 CFR § 19.48(d) and 49 USC § 5325(a), provided that the City is the FTA recipient or a sub-grantee of the FTA recipient, the Contractor agrees to provide the City, FTA, the Comptroller General of the United States, the Secretary of the U.S. Department of Transportation, California or any of their duly authorized representatives access to any books, documents, papers and records of the Contractor that are directly pertinent to or relate to this Contract (1) for the purpose of making audits, examinations, excerpts and transcriptions and (2) when conducting an audit and inspection.

1. In the event of a sole-source Contract, single Bid, single responsive Bid, or competitive negotiated procurement, the Contractor shall maintain and the Contracting Officer, the U.S. Department of Transportation (if applicable) or the representatives thereof shall have the right to examine all books, records, documents and other cost and pricing data related to the Contract price, unless such pricing is based on adequate price competition, established catalog or market prices of commercial items sold in substantial quantities to the public, or prices set by law or regulation, or combinations thereof. Data related to the negotiation or performance of the Contract shall be made available for the purpose of evaluating the accuracy, completeness and currency of the cost or pricing data. The right of examination shall extend to all documents necessary for adequate evaluation of the cost or pricing data, along with the computations and projections used therein, including review of accounting principles and practices that properly reflect all direct and indirect costs anticipated for the performance of the Contract.
2. For Contract modifications or change orders, the Contracting Officer, the U.S. Department of Transportation, if applicable, or their representatives shall have the right to examine all books, records, documents and other cost and pricing data related to a Contract modification, unless such pricing is based on adequate price competition, established catalog or market prices of commercial items sold in substantial quantities to the public, or prices set by law or regulation, or combinations thereof. Data related to the negotiation or performance of the Contract modification or change order shall be made available for the purpose of evaluating the accuracy, completeness and currency of the cost or pricing data. The right of examination shall extend to all documents necessary for adequate evaluation of the cost or pricing data, along with the computations and projections used therein, either before or after execution of the Contract modification or change order for the purpose of conducting a cost analysis. If an examination made after execution of the Contract modification or change order reveals

inaccurate, incomplete or out-of-date data, the Contracting Officer may renegotiate the Contract modification or change order price adjustment, and the City shall be entitled to any reductions in the price that would result from the application of accurate, complete or up-to-date data.

The requirements of this section are in addition to other audit, inspection and record-keeping provisions specified elsewhere in the Contract documents.

GC 52. Suspension of Work

The City may at any time and for any reason within its sole discretion issue a written order to the Contractor suspending, delaying or interrupting all or any part of the Work for a specified period of time. The Contractor shall comply immediately with any such written order and take all reasonable steps to minimize costs allocable to the Work covered by the suspension during the period of work stoppage. Contractor shall continue the Work that is not included in the suspension and shall continue such ancillary activities as are not suspended. The Contractor shall resume performance of the suspended Work upon expiration of the notice of suspension, or upon direction from the City.

The Contractor shall be allowed an equitable adjustment in the Contract price (excluding profit) and/or an extension of the Contract time, to the extent that cost or delays are shown by the Contractor to be directly attributable to any suspension. However, no adjustment shall be made under this section for any suspension, delay or interruption due to the fault or negligence of the Contractor, or for which an equitable adjustment is provided for, or excluded under any other term or condition of the Contract. As soon as reasonably possible but no later than forty-five (45) calendar days, or any other period of time agreed to by the parties, after receipt of the written suspension of work notice, the Contractor shall submit to the Contracting Officer a detailed price and schedule Bid for the suspension, delay or interruption.

GC 53. Claims and Disputes

GC 53.1 General

The Contractor and Owner shall make good faith efforts to resolve any and all Claims and disputes in a timely manner that may from time to time arise during Contractor's performance of the Work. Claims, including those alleging an error or omission shall be directed to the Owner's Transportation Director for action as provided in the "Resolution of Claims and Disputes," below.

It shall be a condition precedent to Claims review by the Transportation Director or his/her designated representative and to mediation or litigation between the Contractor and Owner as to all such matters arising prior to the date final payment is due, that a formal decision on all Contractor Claims be made by the Transportation Director. It shall be a condition precedent that the Contractor appeal any disputed Claim to the Transportation Director prior to initiating mediation or litigation. It shall be a condition precedent that the Contractor mediate any disputed Claim through non-binding mediation as provided herein, prior to initiating litigation. Unless mutually waived in writing by both parties, these provisions apply regardless of 1) whether such matters relate to execution and progress of the Work, or 2) the extent to which the Work has been completed.

Notice of Intent to Claim by Contractor must be made within 72 hours after occurrence of the event giving rise to such Claim, or within 72 hours after the claimant first discovers or should have reasonably discovered the condition giving rise to the Claim, whichever is later. Notice of Intent to Claim and Claims must be made by written notice.

At all times during the course of the dispute resolution process pursuant to the "Resolution of Claims and Disputes," the Contractor shall continue with the Work as directed, in a diligent manner and without delay, or shall conform to the Owner's decision or order, and shall be governed by all applicable provisions of the Contract. Records of the Work shall be kept in sufficient detail to enable payment in

accordance with applicable provisions in the Contract, if this should become necessary.

The making of final payment shall not constitute a waiver of Claims by the Owner including, but not limited to, the following:

- (i) liens, Claims, security interests or encumbrances arising out of the Contract and unsettled;
- (ii) failure of the Work to comply with the requirements of the Contract Documents; or
- (iii) terms of special warranties required by the Contract Documents.

Contractor shall promptly provide an unconditional waiver and release upon final payment in accordance with California Civil Code section 3262 and these Contract Documents. Except to the extent of any Claim arising from City's sole or active negligence, and except to the extent Contractor expressly describes any other disputed Claims for which prior written notice has been given the City and lists the respective dollar amounts in an unconditional waiver and release, the making of final payment shall constitute a waiver of Claims by the Contractor pertaining to any and all costs, expenses, changes or other Claims related to Contract Price or Contract Time, including any synergistic effects attributed to multiple Change Orders. In the event of any disputed Claims between the City and Contractor, the City may withhold from the final payment an amount not to exceed 150% of the disputed amount.

SECTION 4: FEDERAL REQUIREMENTS

CITY OF FRESNO SPECIFICATIONS

PRODUCT PURCHASE CONTRACT FOR:
Two (2) 40' Low Floor Regular All-Electric Fixed Route Bus

BID FILE NUMBER: 3604

FR 1. Termination

FR 1.1 Termination for Convenience

The performance of Work under this Contract may be terminated by the City in accordance with this clause in whole, or from time to time in part, whenever the Contracting Officer shall determine that such termination is in the best interest of the City. Any such termination shall be effected by delivery to the Contractor of a notice of termination specifying the extent to which performance of Work under the Contract is terminated, and the date upon which such termination becomes effective.

After receipt of a notice of termination, and except as otherwise directed by the Contracting Officer, the Contractor shall do the following:

- Stop Work under the Contract on the date and to the extent specified in the notice of termination.
- Place no further orders or subcontracts for materials, services or facilities, except as may be necessary for completion of such portion of the Work under the Contract as is not terminated.
- Terminate all orders and subcontracts to the extent that they relate to the performance of work terminated by the notice of termination; assign to the City in the manner, at the times, and to the extent directed by the Contracting Officer, all of the right, title and interest of the Contractor under the orders and subcontracts so terminated, in which case the City shall have the right, in its discretion, to settle or pay any or all claims arising out of the termination of such orders and subcontracts.
- Settle all outstanding liabilities and all claims arising out of such termination of orders and subcontracts, with the approval or ratification of the Contracting Officer, to the extent he or she may require, which approval or ratification shall be final for all the purposes of this clause.
- Transfer title to the City and deliver in the manner, at the times and to the extent, if any, directed by the Contracting Officer the fabricated or un-fabricated parts, Work in process, completed Work, supplies and other material produced as part of, or acquired in connection with the performance of, the Work terminated, and the completed or partially completed plans, drawings, information and other property which, if the Contract had been completed, would have been required to be furnished to the City.
- Use its best efforts to sell, in the manner, at the times, to the extent, and at the price(s) directed or authorized by the Contracting Officer, any property of the types referred to above, provided, however, that the Contractor shall not be required to extend credit to any purchaser, and may acquire any such property under the conditions prescribed by and at prices approved by the Purchasing Manager, and provided further that the proceeds of any such transfer or disposition shall be applied in reduction of any payments to be made by the City to the Contractor under this Contract or shall otherwise be credited to the price or cost of the Work covered by this Contract or paid in such other manner as the Contracting Officer may direct.
- Complete performance of such part of the Work as shall not have been terminated by the notice of termination.

- Take such action as may be necessary, or as the Contracting Officer may direct, for the protection or preservation of the property related to this Contract that is in the possession of the Contractor and in which the City has or may acquire an interest.

The Contractor shall be paid its costs, including Contract close-out costs, and profit on Work performed up to the time of termination. The Contractor shall promptly submit its termination claim to the City to be paid the Contractor. Settlement of claims by the Contractor under this termination for convenience clause shall be in accordance with the provisions set forth in Part 49 of the Federal Acquisition Regulations (48 CFR 49) except that wherever the word "Government" appears, it shall be deleted and the word "Agency" shall be substituted in lieu thereof.

FR 1.2 Termination for Default

The City may, by written notice of default to the Contractor, terminate the whole or any part of this Contract if the Contractor fails to make delivery of the supplies or to perform the services within the time specified herein or any extension thereof; or if the Contractor fails to perform any of the other material provisions of the Contract, or so fails to make progress as to endanger performance of this Contract in accordance with its terms, and in either of these two circumstances does not cure such failure within a period of ten (10) business days, or such longer period as the Contracting Officer may authorize in writing, after receipt of notice from the Contracting Officer specifying such failure.

If the Contract is terminated in whole or in part for default, the City may procure, upon such terms and in such manner as the Contracting Officer may deem appropriate, supplies or services similar to those so terminated. The Contractor shall be liable to the City for any excess costs for such similar supplies or services and shall continue the performance of this Contract to the extent not terminated under the provisions of this clause.

Except with respect to defaults of Subcontractors, the Contractor shall not be liable for any excess costs if the failure to perform the Contract arises out of a cause beyond the control and without the fault or negligence of the Contractor. If the failure to perform is caused by the default of a Subcontractor, and if such default arises out of causes beyond the control of both the Contractor and Subcontractor, and without the fault or negligence of either of them, the Contractor shall not be liable for any excess costs for failure to perform, unless the supplies or services to be furnished by the Subcontractor were obtainable from other sources and in sufficient time to permit the Contractor to meet the required delivery schedule.

Payment for completed supplies delivered to and accepted by the City shall be at the Contract price. The City may withhold from amounts otherwise due the Contractor for such completed supplies such sum as the Contracting Officer determines to be necessary to protect the City against loss because of outstanding liens or claims of former lien holders.

If, after notice of termination of this Contract under the provisions of this clause, it is determined for any reason that the Contractor was not in default under the provisions of this clause, or that the default was excusable under the provisions of this clause, then the rights and obligations of the parties shall be the same as if the notice of termination had been issued pursuant to termination for convenience of the City.

FR 1.3 Opportunity to Cure (General Provision)

The CITY, in its sole discretion may, in the case of a termination for breach or default, allow the Contractor five (5) calendar days in which to cure the defect. In such case, the Notice of Termination will state the time period in which cure is permitted and other appropriate conditions.

If Contractor fails to remedy to CITY's satisfaction the breach or default of any of the terms, covenants, or conditions of this Contract within [10 days] after receipt by Contractor of written notice from CITY setting forth the nature of said breach or default, CITY shall have the right to terminate the contract without any further obligation to Contractor. Any such termination for default shall not in any way

operate to preclude CITY from also pursuing all available remedies against Contractor and its sureties for said breach or default.

FR 1.4 Waiver of Remedies for any Breach

In the event that CITY elects to waive its remedies for any breach by Contractor of any covenant, term or condition of this contract, such waiver by CITY shall not limit CITY's remedies for any succeeding breach of that or of any other covenant, term, or condition of this contract.

FR 2. Compliance with Federal Lobbying Policy

Contractors who apply or bid for an award of \$100,000 or more shall file the certification required by 49 CFR Part 20, "New Restrictions on Lobbying." Each tier certifies to the tier above that it will not and has not used federal appropriated funds to pay any person or organization for influencing or attempting to influence an officer or employee of any City, a member of Congress, an officer or employee of Congress, or an employee of a member of Congress in connection with obtaining any federal Contract, grant or any other award covered by 31 USC 1352. Each tier shall also disclose the name of any registrant under the Lobbying Disclosure Act of 1995 who has made lobbying contacts on its behalf with non-federal funds with respect to that federal Contract, grant or award covered by 31 USC 1352. Such disclosures are forwarded from tier to tier up to the recipient.

FR 3. Employee Protections

Contract Work Hours and Safety Standards for Awards Not Involving Construction

The Contractor shall comply with all federal laws, regulations, and requirements providing wage and hour protections for non-construction employees, in accordance with 40 U.S.C. § 3702, Contract Work Hours and Safety Standards Act, and other relevant parts of that Act, 40 U.S.C. § 3701 et seq., and U.S. DOL regulations, "Labor Standards Provisions Applicable to Contracts Covering Federally Financed and Assisted Construction (also Labor Standards Provisions Applicable to Non-construction Contracts Subject to the Contract Work Hours and Safety Standards Act)," 29 C.F.R. part 5.

The Contractor shall maintain payrolls and basic payroll records during the course of the work and shall preserve them for a period of three (3) years from the completion of the contract for all laborers and mechanics, including guards and watchmen, working on the contract. Such records shall contain the name and address of each such employee, social security number, correct classifications, hourly rates of wages paid, daily and weekly number of hours worked, deductions made, and actual wages paid.

Such records maintained under this paragraph shall be made available by the Contractor for inspection, copying, or transcription by authorized representatives of the FTA and the Department of Labor, and the Contractor will permit such representatives to interview employees during working hours on the job.

The contractor shall require the inclusion of the language of this clause within subcontracts of all tiers.

FR 4. Clean Air Act and Federal Water Pollution Control Act

The Contractor agrees:

1. It will not use any violating facilities;
2. It will report the use of facilities placed on or likely to be placed on the U.S. EPA "List of Violating Facilities;"
3. It will report violations of use of prohibited facilities to FTA; and
4. It will comply with the inspection and other requirements of the Clean Air Act, as amended, (42 U.S.C. §§ 7401 – 7671q); and the Federal Water Pollution Control Act as amended, (33 U.S.C. §§ 1251-1387).

FR 5. Violation and Breach of Contract

Rights and Remedies

The CITY shall have the following rights in the event that the CITY deems the Contractor guilty of a breach of any term under the Contract.

1. The right to take over and complete the work or any part thereof as CITY for and at the expense of the Contractor, either directly or through other contractors;
2. The right to cancel this Contract as to any or all of the work yet to be performed;
3. The right to specific performance, an injunction or any other appropriate equitable remedy; and
4. The right to money damages.

Rights and Remedies of Contractor

In as much as the Contractor can be adequately compensated by money damages for any breach of this Contract, which may be committed by the CITY, the Contractor expressly agrees that no default, act or omission of the CITY shall constitute a material breach of this Contract, entitling Contractor to cancel or rescind the Contract (unless the CITY directs Contractor to do so) or to suspend or abandon performance.

Remedies

Substantial failure of the Contractor to complete the Project in accordance with the terms of this Agreement will be a default of this Agreement. In the event of a default, the CITY will have all remedies in law and equity, including the right to specific performance, without further assistance, and the rights to termination or suspension as provided herein. The Contractor recognizes that in the event of a breach of this Agreement by the Contractor before the CITY takes action contemplated herein, the CITY will provide the Contractor with sixty (60) days written notice that the CITY considers that such a breach has occurred and will provide the Contractor a reasonable period of time to respond and to take necessary corrective action.

Disputes

1. Example 1: Disputes arising in the performance of this Contract that are not resolved by agreement of the parties shall be decided in writing by the authorized representative of CITY's [title of employee]. This decision shall be final and conclusive unless within [10] days from the date of receipt of its copy, the Contractor mails or otherwise furnishes a written appeal to the [title of employee]. In connection with any such appeal, the Contractor shall be afforded an opportunity to be heard and to offer evidence in support of its position. The decision of the [title of employee] shall be binding upon the Contractor and the Contractor shall abide by the decision.
2. Example 2: The CITY and the Contractor intend to resolve all disputes under this Agreement to the best of their abilities in an informal manner. To accomplish this end, the parties will use an Alternative Dispute Resolution process to resolve disputes in a manner designed to avoid litigation. In general, the parties contemplate that the Alternative Dispute Resolution process will include, at a minimum, an attempt to resolve disputes through communications between their staffs, and, if resolution is not reached at that level, a procedure for review and action on such disputes by appropriate management level officials within the CITY and the Contractor's organization.

In the event that a resolution of the dispute is not mutually agreed upon, the parties can agree to mediate the dispute or proceed with litigation. Notwithstanding any provision of this section, or any other provision of this Contract, it is expressly agreed and understood that any court proceeding arising out of a dispute under the Contract shall be heard by a Court de novo and the court shall not be limited

in such proceeding to the issue of whether the Authority acted in an arbitrary, capricious or grossly erroneous manner.

Pending final settlement of any dispute, the parties shall proceed diligently with the performance of the Contract, and in accordance with the CITY's direction or decisions made thereof.

Performance During Dispute

Unless otherwise directed by CITY, Contractor shall continue performance under this Contract while matters in dispute are being resolved.

Claims for Damages

Should either party to the Contract suffer injury or damage to person or property because of any act or omission of the party or of any of its employees, agents or others for whose acts it is legally liable, a claim for damages therefor shall be made in writing to such other party within a reasonable time after the first observance of such injury or damage.

Remedies

Unless this Contract provides otherwise, all claims, counterclaims, disputes and other matters in question between the CITY and the Contractor arising out of or relating to this agreement or its breach will be decided by arbitration if the parties mutually agree, or in a court of competent jurisdiction within the State in which the CITY is located.

Rights and Remedies

The duties and obligations imposed by the Contract documents and the rights and remedies available thereunder shall be in addition to and not a limitation of any duties, obligations, rights and remedies otherwise imposed or available by law. No action or failure to act by the CITY or Contractor shall constitute a waiver of any right or duty afforded any of them under the Contract, nor shall any such action or failure to act constitute an approval of or acquiescence in any breach thereunder, except as may be specifically agreed in writing.

FR 6. Buy America

The Buy America regulation at 49 C.F.R. § 661.13 requires notification of the Buy America requirements in a recipients' bid or request for proposal for FTA funded contracts. Recipients can draw on the following language for inclusion in their federally funded procurements. Note that recipients are responsible for including the correct Buy America certification based on what they are acquiring. Recipients should not include both the rolling stock and steel, iron, or manufactured products certificates in the documents unless acquiring both in the same procurement.

The contractor agrees to comply with 49 U.S.C. 5323(j) and 49 C.F.R. part 661, which provide that Federal funds may not be obligated unless all steel, iron, and manufactured products used in FTA funded projects are produced in the United States, unless a waiver has been granted by FTA or the product is subject to a general waiver. General waivers are listed in 49 C.F.R. § 661.7. Separate requirements for rolling stock are set out at 49 U.S.C. 5323(j)(2)(C) and 49 C.F.R. § 661.11. The BIDDER must submit to CITY the appropriate Buy America certification below with its [bid or offer]. Bids or offers that are not accompanied by a completed Buy America certification will be rejected as nonresponsive.

FR 7. Suspension and Debarment

This Contract is a covered transaction for purposes of 49 CFR Part 29. As such, the Contractor is required to verify that none of the Contractor, its principals, as defined at 49 CFR 29.995, or affiliates, as defined at 49 CFR 29.905, are excluded or disqualified as defined at 49 CFR 29.940 and 29.945.

The Contractor is required to comply with 49 CFR 29, Subpart C, and must include the requirement to comply with 49 CFR 29, Subpart C, in any lower-tier covered transaction it enters into.

By signing and submitting its Bid, the Bidder certifies as follows:

The certification in this clause is a material representation of fact relied upon by **City of Fresno**. If it is later determined that the Bidder knowingly rendered an erroneous certification, in addition to remedies available to **City of Fresno**, the federal government may pursue available remedies, including but not limited to suspension and/or debarment. The Bidder agrees to comply with the requirements of 49 CFR 29, Subpart C, while this Bid is valid and throughout the period of any Contract that may arise from this Bid. The Bidder further agrees to include a provision requiring such compliance in its lower tier covered transactions.

FR 8. Access to Records and Reports

1. **Record Retention.** The Contractor will retain, and will require its subcontractors of all tiers to retain, complete and readily accessible records related in whole or in part to the contract, including, but not limited to, data, documents, reports, statistics, sub-agreements, leases, subcontracts, arrangements, other third party agreements of any type, and supporting materials related to those records.
2. **Retention Period.** The Contractor agrees to comply with the record retention requirements in accordance with 2 C.F.R. § 200.333. The Contractor shall maintain all books, records, accounts and reports required under this Contract for a period of at not less than three (3) years after the date of termination or expiration of this Contract, except in the event of litigation or settlement of claims arising from the performance of this Contract, in which case records shall be maintained until the disposition of all such litigation, appeals, claims or exceptions related thereto.
3. **Access to Records.** The Contractor agrees to provide sufficient access to FTA and its contractors to inspect and audit records and information related to performance of this contract as reasonably may be required.
4. **Access to the Sites of Performance.** The Contractor agrees to permit FTA and its contractors access to the sites of performance under this contract as reasonably may be required.

Privacy Act

The Contractor agrees to comply with, and assures the compliance of its employees with, the information restrictions and other applicable requirements of the Privacy Act of 1974, 5 U.S.C. § 552a. Among other things, the Contractor agrees to obtain the express consent of the Federal Government before the Contractor or its employees operate a system of records on behalf of the Federal Government. The Contractor understands that the requirements of the Privacy Act, including the civil and criminal penalties for violation of that Act, apply to those individuals involved, and that failure to comply with the terms of the Privacy Act may result in termination of the underlying contract. The Contractor also agrees to include these requirements in each subcontract to administer any system of records on behalf of the Federal Government financed in whole or in part with Federal assistance provided by FTA.

The following access to records requirements apply to this Contract:

Local Governments

In accordance with 49 CFR 18.36(i), the Contractor agrees to provide the City, the FTA Administrator, the Comptroller General of the United States or any of their authorized representatives access to any books, documents, papers and records of the Contractor that are directly pertinent to this Contract for the purposes of making audits, examinations, excerpts and transcriptions. Contractor also agrees, pursuant to 49 CFR 633.17 to provide the FTA Administrator or his authorized representatives including

any PMO Contractor access to Contractor's records and construction sites pertaining to a major capital project, defined at 49 USC 5302(a)1, which is receiving federal financial assistance through the programs described at 49 USC 5307, 5309 or 5311.

State Governments

In accordance with 49 CFR 633.17, the Contractor agrees to provide the City, the FTA Administrator or his authorized representatives, including any PMO Contractor, access to the Contractor's records and construction sites pertaining to a major capital project, defined at 49 USC 5302(a)1, which is receiving federal financial assistance through the programs described at 49 USC 5307, 5309 or 5311. By definition, a major capital project excludes contracts of less than the simplified acquisition threshold currently set at \$100,000.

The Contractor agrees to permit any of the foregoing parties to reproduce by any means whatsoever or to copy excerpts and transcriptions as reasonably needed.

FR 9. Changes to Federal Requirements

Contractor shall at all times comply with all applicable FTA regulations, policies, procedures and directives, including without limitation those listed directly or by reference in the Master Agreement between the PURCHASER and FTA, as they may be amended or promulgated from time to time during the term of this contract. Contractor's failure to so comply shall constitute a material breach of this contract.

FR 10. Civil Rights Requirements

Civil Rights and Equal Opportunity

The CITY is an Equal Opportunity Employer. As such, the CITY agrees to comply with all applicable Federal civil rights laws and implementing regulations. Apart from inconsistent requirements imposed by Federal laws or regulations, the CITY agrees to comply with the requirements of 49 U.S.C. § 5323(h) (3) by not using any Federal assistance awarded by FTA to support procurements using exclusionary or discriminatory specifications.

The following requirements apply to the underlying Contract:

1. **Nondiscrimination:** In accordance with Federal transit law at 49 U.S.C. § 5332, the Contractor agrees that it will not discriminate against any employee or applicant for employment because of race, color, religion, national origin, sex, disability, or age. In addition, the Contractor agrees to comply with applicable Federal implementing regulations and other implementing requirements FTA may issue.
2. **Equal Employment Opportunity:** The following equal employment opportunity requirements apply to the underlying Contract:
3. **Race, Color, Creed, National Origin, Sex:** In accordance with Title VII of the Civil Rights Act, as amended, 42 U.S.C. § 2000e et seq., and Federal transit laws at 49 U.S.C. § 5332, the Contractor agrees to comply with all applicable equal employment opportunity requirements of U.S. Department of Labor (U.S. DOL) regulations, "Office of Federal Contract Compliance Programs, Equal Employment Opportunity, Department of Labor," 41 C.F.R. chapter 60, and Executive Order No. 11246, "Equal Employment Opportunity in Federal Employment," September 24, 1965, 42 U.S.C. § 2000e note, as amended by any later Executive Order that amends or supersedes it, referenced in 42 U.S.C. § 2000e note. The Contractor agrees to take affirmative action to ensure that applicants are employed, and that employees are treated during employment, without regard to their race, color, religion, national origin, or sex (including sexual orientation and gender identity). Such action shall include, but not be limited to, the following: employment, promotion, demotion or transfer, recruitment or recruitment advertising, layoff or

termination; rates of pay or other forms of compensation; and selection for training, including apprenticeship. In addition, the Contractor agrees to comply with any implementing requirements FTA may issue.

4. **Age:** In accordance with the Age Discrimination in Employment Act, 29 U.S.C. §§ 621-634, U.S. Equal Employment Opportunity Commission (U.S. EEOC) regulations, "Age Discrimination in Employment Act," 29 C.F.R. part 1625, the Age Discrimination Act of 1975, as amended, 42 U.S.C. § 6101 et seq., U.S. Health and Human Services regulations, "Nondiscrimination on the Basis of Age in Programs or Activities Receiving Federal Financial Assistance," 45 C.F.R. part 90, and Federal transit law at 49 U.S.C. § 5332, the Contractor agrees to refrain from discrimination against present and prospective employees for reason of age. In addition, the Contractor agrees to comply with any implementing requirements FTA may issue.
5. **Disabilities:** In accordance with section 504 of the Rehabilitation Act of 1973, as amended, 29 U.S.C. § 794, the Americans with Disabilities Act of 1990, as amended, 42 U.S.C. § 12101 et seq., the Architectural Barriers Act of 1968, as amended, 42 U.S.C. § 4151 et seq., and Federal transit law at 49 U.S.C. § 5332, the Contractor agrees that it will not discriminate against individuals on the basis of disability. In addition, the Contractor agrees to comply with any implementing requirements FTA may issue.
6. The Contractor also agrees to include these requirements in each subcontract financed in whole or in part with federal assistance provided by FTA, modified only if necessary to identify the affected parties.

FR 11. Disadvantaged Business Enterprise (DBE)

For all DOT-assisted contracts, each FTA recipient must include assurances that third party contractors will comply with the DBE program requirements of 49 C.F.R. part 26, when applicable. The following contract clause is required in all DOT-assisted prime and subcontracts:

The contractor, subrecipient or subcontractor shall not discriminate on the basis of race, color, national origin, or sex in the performance of this contract. The contractor shall carry out applicable requirements of 49 C.F.R. part 26 in the award and administration of DOT-assisted contracts. Failure by the contractor to carry out these requirements is a material breach of this contract, which may result in the termination of this contract or such other remedy as the recipient deems appropriate, which may include, but is not limited to:

1. Withholding monthly progress payments;
2. Assessing sanctions;
3. Liquidated damages; and/or
4. Disqualifying the contractor from future bidding as non-responsible. 49 C.F.R. § 26.13(b).

Further, recipients must establish a contract clause to require prime contractors to pay subcontractors for satisfactory performance of their contracts no later than 30 days from receipt of each payment the recipient makes to the prime contractor. 49 C.F.R. § 26.29(a). Finally, for contracts with defined DBE contract goals, each FTA recipient must include in each prime contract a provision stating that the contractor shall utilize the specific DBEs listed unless the contractor obtains the recipient's written consent; and that, unless the recipient's consent is provided, the contractor shall not be entitled to any payment for work or material unless it is performed or supplied by the listed DBE. 49 C.F.R. § 26.53(f) (1).

As an additional resource, recipients can draw on the following language for inclusion in their federally funded procurements.

Overview

It is the policy of the CITY and the United States Department of Transportation (“DOT”) that Disadvantaged Business Enterprises (“DBE’s”), as defined herein and in the Federal regulations published at 49 C.F.R. part 26, shall have an equal opportunity to participate in DOT-assisted contracts. It is also the policy of the CITY to:

1. Ensure nondiscrimination in the award and administration of DOT-assisted contracts;
2. Create a level playing field on which DBE’s can compete fairly for DOT-assisted contracts;
3. Ensure that the DBE program is narrowly tailored in accordance with applicable law;
4. Ensure that only firms that fully meet 49 C.F.R. part 26 eligibility standards are permitted to participate as DBE’s;
5. Help remove barriers to the participation of DBEs in DOT assisted contracts;
6. To promote the use of DBEs in all types of federally assisted contracts and procurement activities; and
7. Assist in the development of firms that can compete successfully in the marketplace outside the DBE program.

This Contract is subject to 49 C.F.R. part 26. Therefore, the Contractor must satisfy the requirements for DBE participation as set forth herein. These requirements are in addition to all other equal opportunity employment requirements of this Contract. The CITY shall make all determinations with regard to whether or not a Bidder/Offeror is in compliance with the requirements stated herein. In assessing compliance, the CITY may consider during its review of the Bidder/Offeror’s submission package, the Bidder/Offeror’s documented history of non-compliance with DBE requirements on previous contracts with the CITY.

Contract Assurance

The Contractor, subrecipient or subcontractor shall not discriminate on the basis of race, color, national origin, or sex in the performance of this Contract. The Contractor shall carry out applicable requirements of 49 C.F.R. part 26 in the award and administration of DOT-assisted contracts. Failure by the Contractor to carry out these requirements is a material breach of this Contract, which may result in the termination of this Contract or such other remedy as the CITY deems appropriate.

FR 12. Federal Energy Conservation Requirements

The contractor agrees to comply with mandatory standards and policies relating to energy efficiency, which are contained in the state energy conservation plan issued in compliance with the Energy Policy and Conservation Act.

FR 13. Federal Funding, Incorporation of FTA Terms and Federal Changes

The preceding provisions include, in part, certain standard terms and conditions required by the Department of Transportation, whether or not expressly set forth in the preceding Contract provisions. All contractual provisions required by DOT, as set forth in FTA Circular 4220.1F or its successors are hereby incorporated by reference. Anything to the contrary herein notwithstanding, all FTA mandated terms shall be deemed to control in the event of a conflict with other provisions contained in this agreement. The Contractor shall not perform any act, fail to perform any act or refuse to comply with any City of Fresno requests that would cause City of Fresno to be in violation of the FTA terms and conditions.

The Contractor shall at all times comply with all applicable FTA regulations, policies, procedures and directives, including without limitation those listed directly or by reference in the Master Agreement between City and FTA, as they may be amended or promulgated from time to time during the term of this Contract. Contractor’s failure to so comply shall constitute a material breach of this Contract.

FR 14. No Government Obligation to Third Parties

1. The Recipient and Contractor acknowledge and agree that, notwithstanding any concurrence by the Federal Government in or approval of the solicitation or award of the underlying Contract, absent the express written consent by the Federal Government, the Federal Government is not a party to this Contract and shall not be subject to any obligations or liabilities to the Recipient, Contractor or any other party (whether or not a party to that contract) pertaining to any matter resulting from the underlying Contract.
2. The Contractor agrees to include the above clause in each subcontract financed in whole or in part with Federal assistance provided by the FTA. It is further agreed that the clause shall not be modified, except to identify the subcontractor who will be subject to its provisions.

FR 15. Safe Operation of Motor Vehicles

Seat Belt Use

The Contractor is encouraged to adopt and promote on-the-job seat belt use policies and programs for its employees and other personnel that operate company-owned vehicles, company-rented vehicles, or personally operated vehicles. The terms “company-owned” and “company-leased” refer to vehicles owned or leased either by the Contractor or CITY.

Distracted Driving

The Contractor agrees to adopt and enforce workplace safety policies to decrease crashes caused by distracted drivers, including policies to ban text messaging while using an electronic device supplied by an employer, and driving a vehicle the driver owns or rents, a vehicle Contractor owns, leases, or rents, or a privately-owned vehicle when on official business in connection with the work performed under this agreement.

FR 16. Recycled Products

The Contractor agrees to provide a preference for those products and services that conserve natural resources, protect the environment, and are energy efficient by complying with and facilitating compliance with Section 6002 of the Resource Conservation and Recovery Act, as amended, 42 U.S.C. § 6962, and U.S. Environmental Protection CITY (U.S. EPA), “Comprehensive Procurement Guideline for Products Containing Recovered Materials,” 40 C.F.R. part 247.

FR 17. Fly America

Fly America Requirements

1. Definitions. As used in this clause- “International air transportation” means transportation by air between a place in the United States and a place outside the United States or between two places both of which are outside the United States. “United States” means the 50 States, the District of Columbia, and outlying areas. “U.S.-flag air carrier” means an air carrier holding a certificate under 49 U.S.C. Chapter 411.
2. When Federal funds are used to fund travel, Section 5 of the International Air Transportation Fair Competitive Practices Act of 1974 (49 U.S.C. 40118) (Fly America Act) requires contractors, recipients, and others use U.S.-flag air carriers for U.S. Government-financed international air transportation of personnel (and their personal effects) or property, to the extent that service by those carriers is available. It requires the Comptroller General of the United States, in the absence of satisfactory proof of the necessity for foreign-flag air transportation, to disallow expenditures from funds, appropriated or otherwise established for the account of the United States, for international air transportation secured aboard a foreign-flag air carrier if a U.S.-flag air carrier is available to provide such services.

3. If available, the Contractor, in performing work under this contract, shall use U.S.-flag carriers for international air transportation of personnel (and their personal effects) or property.
4. In the event that the Contractor selects a carrier other than a U.S.-flag air carrier for international air transportation, the Contractor shall include a statement on vouchers involving such transportation essentially as follows:

Statement of Unavailability of U.S.-Flag Air Carriers

International air transportation of persons (and their personal effects) or property by U.S.-flag air carrier was not available or it was necessary to use foreign-flag air carrier service for the following reasons. See FAR § 47.403. [State reasons]:

5. The Contractor shall include the substance of this clause, including this paragraph (5), in each subcontract or purchase under this contract that may involve international air transportation.

FR 18. Cargo Preference Requirements

Cargo Preference - Use of United States-Flag Vessels

The contractor agrees:

1. To use privately owned United States-Flag commercial vessels to ship at least 50 percent of the gross tonnage (computed separately for dry bulk carriers, dry cargo liners, and tankers) involved, whenever shipping any equipment, material, or commodities pursuant to the underlying contract to the extent such vessels are available at fair and reasonable rates for United States-Flag commercial vessels;
2. To furnish within 20 working days following the date of loading for shipments originating within the United States or within 30 working days following the date of loading for shipments originating outside the United States, a legible copy of a rated, "on-board" commercial ocean bill-of-lading in English for each shipment of cargo described in the preceding paragraph to the Division of National Cargo, Office of Market Development, Maritime Administration, Washington, DC 20590 and to the FTA recipient (through the contractor in the case of a subcontractor's bill-of-lading.); and
3. To include these requirements in all subcontracts issued pursuant to this contract when the subcontract may involve the transport of equipment, material, or commodities by ocean vessel.

FR 19. Program Fraud and False, Fraudulent Statements or Related Acts

1. The Contractor acknowledges that the provisions of the Program Fraud Civil Remedies Act of 1986, as amended, 31 U.S.C. § 3801 et seq. and U.S. DOT regulations, "Program Fraud Civil Remedies," 49 C.F.R. part 31, apply to its actions pertaining to this Project. Upon execution of the underlying contract, the Contractor certifies or affirms the truthfulness and accuracy of any statement it has made, it makes, it may make, or causes to be made, pertaining to the underlying contract or the FTA assisted project for which this contract work is being performed. In addition to other penalties that may be applicable, the Contractor further acknowledges that if it makes, or causes to be made, a false, fictitious, or fraudulent claim, statement, submission, or certification, the Federal Government reserves the right to impose the penalties of the Program Fraud Civil Remedies Act of 1986 on the Contractor to the extent the Federal Government deems appropriate.
2. The Contractor also acknowledges that if it makes, or causes to be made, a false, fictitious, or fraudulent claim, statement, submission, or certification to the Federal Government under a contract connected with a project that is financed in whole or in part with Federal assistance originally awarded by FTA under the authority of 49 U.S.C. chapter 53, the Government

reserves the right to impose the penalties of 18 U.S.C. § 1001 and 49 U.S.C. § 5323(l) on the Contractor, to the extent the Federal Government deems appropriate.

3. The Contractor agrees to include the above two clauses in each subcontract financed in whole or in part with Federal assistance provided by FTA. It is further agreed that the clauses shall not be modified, except to identify the subcontractor who will be subject to the provisions.

FR 20. Bus Testing

The Contractor agrees to comply with 49 U.S.C. A 5323(c) and FTA's implementing regulation at 49 CFR Part 665 and shall perform the following:

1. A manufacturer of a new bus model or a bus produced with a major change in components or configuration shall provide a copy of the final test report to MTD at a point in the procurement process specified by MTD which will be prior to MTD's final acceptance of the first vehicle.
2. A manufacturer who releases a report under paragraph (a) above shall provide notice to the operator of the testing facility that the report is available to the public.
3. If the manufacturer represents that the vehicle was previously tested, the vehicle being sold should have the identical configuration and major components as the vehicle in the test report, which must be provided to MTD prior to MTD's final acceptance of the first vehicle. If the configuration or components are not identical, the manufacturer shall provide a description of the change and the manufacturer's basis for concluding that it is not a major change requiring additional testing.
4. If the manufacturer represents that the vehicle is "grandfathered" (has been used in mass transit service in the United States before October 1, 1988, and is currently being produced without a major change in configuration or components), the manufacturer shall provide the name and address of the recipient of such a vehicle and the details of that vehicle's configuration and major components.

FR 21. Pre-Award and Post-Delivery Audits

The Contractor agrees to comply with 49 U.S.C. § 5323(l) and FTA's implementing regulation at 49 CFR Part 663 and to submit the following certifications:

1. **Buy America requirements:** The Contractor shall complete and submit a declaration certifying either compliance or noncompliance with Buy America. If the Bidder/Offeror certifies compliance with Buy America, it shall submit documentation which lists:
 - a. Component and subcomponent parts of the rolling stock to be purchased identified by manufacturer of the parts, their country of origin and costs; and
 - b. The location of the final assembly point for the rolling stock, including a description of the activities that will take place at the final assembly point and the cost of final assembly.
2. **Solicitation specification requirements:** The Contractor shall submit evidence that it will be capable of meeting the bid specifications.
3. **Federal Motor Vehicle Safety Standards (FMVSS):** The Contractor shall submit
 - a. manufacturer's FMVSS self-certification sticker information that the vehicle complies with relevant FMVSS; or(2) manufacturer's certified statement that contracted buses will not be subject to FMVSS regulations.

SECTION 5: SPECIAL CONDITIONS

CITY OF FRESNO SPECIFICATIONS

PRODUCT PURCHASE CONTRACT FOR:
Two (2) 40' Low Floor Regular All-Electric Fixed Route Bus

BID FILE NUMBER: 3604

SP 1. Pricing Conditions

The pricing for the Two (2) 40' Low Floor Regular All-Electric Fixed Route Bus shall remain firm and fixed at the Bid price until the NTP.

SP 2. Authorization To Place Orders

Names of individuals authorized to place orders will be provided in writing by the City upon or following the issuance by the City of the Notice to Proceed. City may modify such writing from time to time by notice to the Contractor.

SP 3. Contractor's Authorized Representative

The name, mailing address, telephone number, any e-mail address and any facsimile number of Contractor's authorized representative shall be provided in writing by Contractor no later than 5 calendar days following the issuance by the City of the Notice to Proceed.

SP 4. Change Orders

The City of Fresno reserves the right to add, modify or delete items from the Contract or Special Conditions or Technical Specifications. Any changes shall be made only by means of a formal Change Order signed by both the City and the Seller.

SP 5. Deliveries

SP 5.1 Bus Delivery

Cancellation of backorders is not acceptable. Contractor must fill order in its entirety. Except as otherwise expressly provided herein, delivery(ies) shall be made within **EIGHTEEN (18) months, FIVE-HUNDRED FORTY-EIGHT (548) calendar days** from NTP or must receive written approval from the City for an extension of the delivery date. Any goods deemed by the City to be defective, or any wrong parts shipped in error, must be replaced within **FIVE (5) calendar days** of notification. The City must be notified **FORTY-EIGHT (48) hours** in advance of delivery or shipment may be refused.

Delivery of items is to be F.O.B. DESTINATION, FREIGHT PREPAID AND ALLOWED, to:

City of Fresno
Department of Transportation/FAX Maintenance
2223 G Street
Fresno, CA 93706

SP 5.2 Delivery Schedule

Hours of delivery shall be 8:00 am to 4:00 pm Monday through Friday unless arrangements are made prior to delivery, excluding all City recognized Holidays.

Upon the Award and the City's Notice to Proceed, an order of Two (2) 40' Low Floor Regular All-Electric Fixed Route Bus shall be placed on order with the awarded Contractor. The buses shall be

delivered no later than **EIGHTEEN (18) months, FIVE-HUNDRED FORTY-EIGHT (548) calendar days**. The Contractor shall provide its bus delivery schedule for each bus and deliverables specified herein for review and approval within **THIRTY (30) calendar day** of NTP.

SP 5.3 Non-Delivery

If the Contractor fails to meet delivery requirements, the City may, but is not obligated to, procure the goods from another source and recover any loss occasioned thereby (including, without limitation, any increase in cost and liquidated damages for Contractor's delay up to date of delivery and acceptance by City of goods from another source), from any unpaid balance due the Contractor or through reduction of future invoices. Otherwise, Contractor will reimburse City within 30 days of receipt of invoice from the City. The price paid by the City shall be considered the prevailing market price at the time purchase is made. City will notify Contractor of any decision to procure the goods from another source. Such notification may be by telephone, electronic mail, or facsimile to Contractor or Contractor's authorized representative.

SP 5.4 Liquidated Damages

It is mutually understood and agreed by and between the parties by executing the Contract each agree that time is of the essence with respect to the completion of the Work and that in case of any failure on the part of the Contractor to deliver the buses within the time specified in "Delivery Schedule," except for any excusable delays as provided in "Excusable Delays/Force Majeure" or any extension thereof, the City will be damaged thereby. The amount of said damages, being difficult if not impossible of definite ascertainment and proof, it is hereby agreed that the Contractor shall be liable for and shall pay the amount of such damages due to the City as fixed, agreed, and liquidated damages, and not as a penalty the sum of **TWO-HUNDRED FIFTY DOLLARS (\$250.00)** per day per bus/item for every calendar day not delivered in substantially good condition as inspected by the City at the time released for shipment, or delay in delivery of equipment or materials from the maximum delivery date as specified herein or in any written extensions of time granted by the City. Such payment due to the City will be deducted by the City from any payments due to the Contractor for item(s) delivered. Otherwise, Contractor will reimburse City within 30 days of receipt of invoice from the City.

The Contractor hereby agrees to pay the aforementioned amounts as fixed, agreed and liquidated damages, and not by way of penalty, to the City and further authorizes the City to deduct the amount of the damages from money due the Contractor under the Contract, computed as aforesaid. If the money due the Contractor is insufficient or no money is due the Contractor, then the Contractor shall pay the City the difference or the entire amount, whichever may be the case, within thirty (30) days after receipt of a written demand by the Contracting Officer.

The payment of aforesaid fixed, agreed and liquidated damages shall be in lieu of any damages for any loss of profit, loss of revenue, loss of use, or for any other direct, indirect, special or consequential losses or damages of any kind whatsoever that may be suffered by the City arising at any time from the failure of the Contractor to fulfill the obligations referenced in this clause in a timely manner.

SP 6. Contract Deliverable Requirements List (CDRL)

Contract deliverables associated with this Contract are set forth in the table below, along with other pertinent information. Contract deliverables shall be submitted in accordance with "Section 6: Technical Specifications." Due dates shown note the last acceptable date for receipt of Contract deliverables. The City will consider early receipt of Contract deliverables on a case-by-case basis. The reference section designates the appropriate specification section(s) where the requirement is referenced.

An itemized pricing for all components, parts, diagnostic equipment, tooling, and training (TS 8.7) deliverables shall be submitted with bid package. Itemized pricing form is found on page 243-247 EXHIBIT "A".

SP 6.1 Contract Deliverables

Deliverable		City Action	Due Date	Format	Quantity Due
1.	Bus Testing— Altoona Test Report	Review	Prior to delivery	Hardcopy	1
2.	List of serialized units installed on each bus	Review	With each delivered bus	Electronic media	1 per bus
3.	Copy of Manufacturers' formal Quality Assurance Program	Review	Pre-award site visit	Hardcopy	1 per order
4.	QA manufacturing certificate	Review	With each delivered bus	Hardcopy	1 per bus
5.	QA purchasing certifications acknowledging receipt of applicable specification	Review	30 days following first Pre-Production Meeting	Hardcopy	1 per order
6.	Pre-Delivery Bus Documentation Package	Review	With each delivered bus	Hardcopy	1 per bus
7.	Motor Vehicle Pollution Requirements Certificate	Review	With each delivered bus	Hardcopy	1 per order
8.	Engine Emissions Certificate—NO _x levels	Review	Prior to completion	Hardcopy	1 per order
9.	Pre-Production Meeting minutes	Approval	30 days after each meeting	Hardcopy	2 originals per order
10.	Operator's log and incident report	Review	With each bus delivery if drive-away service is used	Hardcopy	1 per bus
11.	Title documentation	Review	10 days prior to bus delivery	Hardcopy	1 per bus
12.	Performance bond	Review	30 days following execution of Contract	Hardcopy	1 per order
13.	Insurance certificates	Approval	Before Work commences	Hardcopy	1 per order
14.	Engineering support	Review	During Pre-Production Meeting	Contracts	1 per order
15.	Training instructor information	Approval	30 days prior to delivery		1 per order
16.	Training curriculum	Approval	30 days prior to delivery	Electronic media	1 per order
17.	Teaching materials	Review	During classroom instruction	Hardcopy	1 per order
18.	Professionally prepared mechanics' "Bus Orientation" training video	Review	30 days prior to first production bus	Electronic Media	5 per order
19.	Final preventative maintenance manuals	Review	90 days after City written approval	Hardcopy	3 per order
				Electronic media	3 per order
20.	Final diagnostic procedures manuals	Review	90 days after City written approval	Hardcopy	3 per order
				Electronic media	3 per order

Deliverable		City Action	Due Date	Format	Quantity Due
21.	Final parts manuals	Approval	90 days after City written approval	Hardcopy	3 per order
				Electronic media	3 per order
22.	Component repair manuals (City approval/review period of 90 days from date of receipt)	Approval	90 days after City written approval of OEM component repair list	Hardcopy	3 per order
				Electronic media	3 per order
23.	Draft preventative maintenance manuals (City approval/review period of 90 days from date of receipt)	Approval	With delivery	Hardcopy	10 per order
24.	Draft diagnostic procedures manuals (City approval/review period of 90 days from date of receipt)	Approval	With delivery	Hardcopy	10 per order
25.	Draft parts manuals (City approval/review period of 90 days from date of receipt)	Approval	With delivery	Hardcopy	10 per order
26.	List of OEM component repair manuals	Approval	With delivery	Hardcopy	10 per order
27.	Draft operators' manuals (City approval/review period of 90 days from date of receipt)	Approval	With maximum of 30 days prior to start of production	Hardcopy	10 per order
28.	Final operators' manuals	Review	30 days following City approval of draft manual	Hardcopy	10 per bus
29.	Recommended spare parts list, including bill of materials	Review	60 days prior to shipment of first bus	Hardcopy	1 per order
30.	Part number index	Approval	60 days prior to shipment of first bus	Hardcopy	1 per order
				Spreadsheet	1 per order
31.	Current price list	Review	90 days after City written approval of draft parts manual	Hardcopy	20 per order
32.	In-process drawings	Review	30 days prior to production	Scale drawings	1 per order
33.	Electrical and air schematics	Review	30 days prior to production	Hardcopy	3 per order
				Electronic media	3 per order
34.	As-built drawings	Review	Within 60 days after final bus delivery	Electronic media	1
35.	Material samples	Review	By conclusion of Pre-Production Meetings		1
36.	Undercoating system program	Approval	First Pre-Production Meeting	Hardcopy	1
37.	Flooring certificate	Review	First Pre-Production Meeting	Certificate/ copy of purchase order	1

	Deliverable	City Action	Due Date	Format	Quantity Due
38.	Interior features – fire-resistance certificates	Review	Prior to completion	Certificates	1 per order
39.	Crashworthiness	Review	Pre-award audit	Certificate	1
40.	Technical review of electronic functionality	Approval	Prior to production	Hardcopy	1
41.	Interior security camera layout	Approval	Prior to completion	Copies of interior views	1 each
42.	Technical review of power plant		Prior to production	Hardcopy	1 per order
43.	Power plant certifications	Review	Prior to completion	Hardcopy	1 per order
44.	Striping layout	Approval	Prior to production	Hardcopy	1
45.	Resolution of issues “subject to City approval”	Approval	Prior to production	Hardcopy	1 per order
46.	List of bus OEM Specialty Tools	Review	First Pre-Production Meeting	Hardcopy	1 per order
47.	List of bus OEM Tow Equipment	Review	First Pre-Production Meeting	Hardcopy	1 per order

SP 7. Emergency Orders/Repairs

The City at times may require part(s) or repairs immediately in an emergency. The emergency may be handled on a will call basis. Therefore, Contractor shall maintain an inventory and a Manufactures’ licensed warranty repair facilities for any and all major parts and components provided by the Contractor installed in the buses ordered under this contract. The warehouse and manufacturer licensed warranty repair facilities shall be within a 25-mile radius of Fresno City Hall (2600 Fresno Street, Fresno, CA) and a 24-hour emergency call number. Contractor shall expedite supply of the parts(s) or a technician for repairs, and in any event, delivery or repairs shall be delivered or repairs commenced no more than 24 hours from City’s call.

SP 8. Payment

The City shall pay and the Contractor shall accept the amounts set forth in the cost proposal as full compensation for all costs and expenses of completing the Work in accordance with the Contract, including but not limited to all labor, equipment and material required; overhead; expenses; storage and shipping; risks and obligations; taxes (as applicable); fees and profit; and any unforeseen costs.

The Contractor must invoice the City of Fresno - Department of Transportation/FAX, in order to initiate the payment process. Invoices shall be supplied in duplicate and conspicuously displayed with the City of Fresno Purchase Order Number and shall be sent to:

City of Fresno
Department of Transportation/FAX
2223 G Street
Fresno, CA 93706

SP 8.1 Payment Terms

All payments will be made as provided herein, less any additional amount withheld as provided below and less any amounts for liquidated damages in accordance with “Liquidated Damages for Late Delivery of the Bus”. The Contractor will invoice the City with two separate invoices, first invoice for EIGHTY PERCENT (80%) and the second (final) invoice of the remaining TWENTY PERCENT (20%).

The City will make payments for EIGHTY PERCENT (80%) of buses at the unit prices itemized in the price schedule within THIRTY (30) calendar days after the delivery and acceptance of each bus and receipt of a proper invoice.

The City will make payments for spare parts and/or equipment at the unit prices itemized in the price schedule within THIRTY (30) calendar days after the delivery and acceptance of said spare parts and/or equipment and receipt of a proper invoice.

The City will make a final payment for all withholding within THIRTY (30) calendar days of receipt of a final proper invoice and the following:

1. Delivery and acceptance of all Contract deliverables, including manuals and other documentation required by the Contract, excluding training.
2. Contractor provision of any certifications as required by law and/or regulations.
3. Completion of post-delivery audits required under the Contract.
4. City acceptance after the THIRTY (30) day "Testing and Acceptance Period".

The Contractor may not charge interest for any late payment.

SP 9. Inspection, Tests, and Repairs

SP 9.1 Repair Performance

SP 9.1.1 Repairs by Contractor

After non-acceptance of the bus, the Contractor must begin Work within five (5) working days after receiving notification from the City of failure of acceptance tests. The City shall make the bus available to complete repairs timely with the Contractor repair schedule.

The Contractor shall provide, at its own expense, all spare parts, tools, and space required to complete the repairs. At the City's option, the Contractor may be required to remove the bus from the City's property while repairs are being made. If the bus is removed from the City's property, then repair procedures must be diligently pursued by the Contractor's representatives, and the Contractor shall assume risk of loss while the bus is under its control.

SP 9.1.2 Repairs by the City

The City will not take responsibility to correct Defects, except to replace defective parts as instructed by the Contractor.

1. **Parts used.** If the City performs the repairs after non-acceptance of the bus, it shall correct or repair the Defect and any Related Defects using Contractor-specified parts available from its own stock or those supplied by the Contractor specifically for this repair. Reports of all repairs covered by this procedure shall be submitted by the City to the Contractor for reimbursement or replacement of parts monthly, or at a period to be mutually agreed upon. The Contractor shall provide forms for these reports.
2. **Contractor-supplied parts.** If the Contractor supplies parts for repairs that are being performed by the City after non-acceptance of the bus, then these parts shall be shipped prepaid to the City.
3. **Return of defective components.** The Contractor may request that parts covered by this provision be returned to the manufacturing plant. The total costs for this action shall be paid by the Contractor.
4. **Reimbursement for labor.** The City shall be reimbursed by the Contractor for labor. The amount shall be determined by the City to cover all expenses including, but not limited to, a mechanic at a straight time wage rate, fringe benefits, and overhead, plus the cost of

transportation of the bus if such action was necessary, 160 percent of the shop labor rate, per person hour required to correct the defect. These wage and fringe benefit rates shall be adjusted based on the rates in effect in the City's service garage at the time the Defect correction is made. The amount determined shall be a minimum labor rate of **\$85.00 per hour**.

5. **Reimbursement for parts.** The City shall be reimbursed by the Contractor for defective parts that must be replaced to correct the Defect. The reimbursement shall include taxes where applicable and fifteen (15) percent handling costs.

SP 9.2 Configuration and Performance Approval

In order to assess the Contractor's compliance with the Technical Specifications, the City and the Contractor shall, at the Pre-Production Meeting, jointly develop a configuration and performance review document for review of the pilot vehicle. This document shall include appropriate performance standards for each test that is being required, and the document shall become part of the official record of the Pre-Production Meeting.

SP 9.3 First Article Inspection – Production

The purpose of a first article inspection is to confirm that any components, systems, subsystems, major assemblies, subassemblies, products, parts, apparatuses, articles and other materials comply with the Technical Specifications and other Contract documents.

Where required by the Contract documents or requested by the City, the Contractor shall cause first article inspections to be conducted. A first article inspection may include both a physical configuration inspection and a functional demonstration. First article inspections shall be conducted at the Contractor or Subcontractor's facility. The Contractor shall furnish to the City prior to each first article inspection a written inspection and demonstration plan for each item for review. The City's inspectors will attend each first article inspection unless the City provides a written waiver of its right to attend any such inspection. The results of each first article inspection shall be documented by the Contractor in a format deemed acceptable by the City, and all documents relating to the inspection shall be forwarded to the City.

SP 9.4 Post-Delivery Tests

The City will conduct acceptance tests on each delivered bus. These tests shall be completed within thirty (30) days after bus delivery and shall be conducted in accordance with written test plans. The purpose of these tests is to identify Defects that have become apparent between the time of bus release and delivery to the City. The post-delivery tests shall include visual inspection and bus operations. No post-delivery test shall apply criteria that are different from the criteria applied in an analogous pre-delivery test (if any).

Buses that fail to pass the post-delivery tests are subject to non-acceptance. The City shall record details of all Defects on the appropriate test forms and shall notify the Contractor of acceptance or non-acceptance of each bus according to "Inspection, Testing and Acceptance" after completion of the tests. The Defects detected during these tests shall be repaired according to the procedures defined in "Repairs after Non-Acceptance."

SP 9.5 Repairs after Non-Acceptance

The Contractor, or its designated representative, shall perform the repairs after non-acceptance. If the Contractor fails or refuses to begin the repairs within five (5) days, then the Work may be done by the City's personnel with reimbursement by the Contractor.

SP 10. Service and Parts

SP 10.1 Contractor Service and Parts Support

The Contractor shall state on the form Contractor Service and Parts Support Data the representatives responsible for assisting the City, as well as the location of the nearest distribution center and Manufacturers' warranty repair facilities for major parts and components installed on the bus, which shall furnish a complete supply of parts, components, and Manufacturers' warranty repairs for the repair and maintenance of the buses to be supplied. The Contractor also shall state below, or by separate attachment, its policy on transportation charges for parts other than those covered by warranty.

SP 10.2 Documentation

The Contractor shall provide an electronic copy and TWO (2) printed current maintenance manual(s) to include preventative maintenance procedures, diagnostic procedures and troubleshooting guides, and major component service manuals, an electronic copy and TWO (2) printed current parts manual(s), and an electronic copy and TWO (2) printed standard operator's manual(s) as part of this Contract. The Contractor also shall exert its best efforts to keep maintenance manuals, operator's manuals and parts books up to date for a period of fifteen (15) years. The supplied manuals shall incorporate all equipment ordered on the buses covered by this procurement. In instances where copyright restrictions or other considerations prevent the Contractor from incorporating major components information into the bus parts and service manuals, separate manual sets as published by the subcomponent supplier will be provided.

SP 10.3 Parts Availability Guarantee

The Contractor hereby guarantees to provide, within reasonable periods of time, the spare parts, software and all equipment necessary to maintain and repair the buses supplied under this Contract for a period of at least fifteen (15) years after the date of acceptance. Parts shall be interchangeable with the original equipment and shall be manufactured in accordance with the quality assurance provisions of this Contract. Prices shall not exceed the Contractor's then-current published catalog prices.

Where the parts ordered by the City are not received within two (2) working days of the agreed-upon time and date and a bus procured under this Contract is out of service due to the lack of said ordered parts, then the Contractor shall provide the City, within eight (8) hours of the City's verbal or written request, the original Suppliers' and/or manufacturers' parts numbers, company names, addresses, telephone numbers and contact persons' names for all of the specific parts not received by the City.

Where the Contractor fails to honor this parts guarantee or parts ordered by the City are not received within thirty (30) days of the agreed-upon delivery date, then the Contractor shall provide to the City, within seven (7) days of the City's verbal or written request, the design and manufacturing documentation for those parts manufactured by the Contractor and the original Suppliers' and/or manufacturers' parts numbers, company names, addresses, telephone numbers and contact persons' names for all of the specific parts not received by the City. The Contractor's design and manufacturing documentation provided to the City shall be for its sole use in regard to the buses procured under this Contract and for no other purpose.

SP 10.4 City-Furnished Property

In the event that equipment or other goods or materials are specified in the Technical Specifications to be furnished by the City to the Contractor for incorporation in the Work, the following provisions shall apply:

The City shall furnish the equipment, goods or materials in a timely manner so as not to delay Contract delivery or performance dates. If City-furnished property is received in a condition not suitable for the intended use, then the Contractor shall promptly notify the City, detailing the facts, and at the City's

expense repair, modify, return or take such other action as directed by the City. The parties may conduct a joint inspection of the property before the Contractor takes possession to document its condition.

The City retains title to all City-furnished property. Upon receipt of the City-furnished property, the Contractor assumes the charge and care of the property and bears the risk of loss or damage due to action of the elements or from any other cause. The Contractor shall provide appropriate protection for all such property during the progress of the Work. Should any City-furnished equipment or materials be damaged, such property shall be repaired or replaced at the Contractor's expense to the satisfaction of the City. No extension of time will be allowed for repair or replacement of such damaged items. Should the Contractor not repair or replace such damaged items, the City shall have the right to take corrective measures itself and deduct the cost from any sums owed to the Contractor.

Warranty administration and enforcement for City-furnished equipment are the responsibility of the City, unless the parties agree to transfer warranty responsibility to the Contractor.

SP 11. Federal Motor Vehicle Safety Standards (FMVSS)

The Contractor shall submit one (1) manufacturer's FMVSS self-certification, Federal Motor Vehicles Safety Standards that the vehicle complies with relevant FMVSS or two manufacturer's certified statement that the contracted buses will not be subject to FMVSS regulations.

SP 12. Escrow Accounts

SP 12.1 Software Escrow Account

All the Contractor's policies shall contain an endorsement naming the City as an additional insured and providing that written notice shall be given to the City's location at least thirty (30) days prior to termination, cancellation or material reduction of coverage in the policy; provided, however, that such notice may be given on ten (10) days' notice if the termination is due to nonpayment of premium.

Upon execution of the Contract, the Contractor shall provide the City a list of all OEM software comprising proprietary works ("Proprietary Software") for all major vehicle subsystems. From time to time and only upon request, information contained within the listed software may be made available to the City through the OEM of the vehicle subsystem. The Contractor and OEM are not obligated to provide copies of source code, as this is proprietary intellectual property; however, the Contractor is obligated to assist the City with any technical assistance for the duration of the life of the vehicle. It is the City's prerogative to evaluate the long-term viability of the Contractor and its Subcontractors and Suppliers based upon the criteria set forth in "Qualification Requirements."

Contractor shall place copies of the above source codes and unprotected application software in an escrow account to the benefit of the Agency. An escrow agreement is required should the contractor become in poor financial condition; changes ownership; declares bankruptcy or is about to declare bankruptcy; or if the Contractor fails to perform its obligation to either manufacture, support and maintain the product being produced for the Agency. If any of these events occur, the escrow agent shall release the source code and unprotected application software to the Agency so that the Agency can have the products completed, produced and maintained. Contractor also grants Agency full use, royalty free license of the escrowed source code and application software and documentation to support the purchased vehicles and equipment. Agency shall not reproduce or modify source code, applications, or documentation for distribution outside of the Agency. (See Appendix B)

SP 12.2 Manufacturing Data Escrow Account

Upon execution of the Contract, the Contractor shall provide the Agency a list of all manufacturing data comprising proprietary works ("Proprietary Data") for all major vehicles and equipment subsystems

Agency has contracted for. From time to time and only upon request, information contained within the listed data may be made available to the Agency through the OEM of the vehicle and equipment subsystems. The Contractor is obligated to assist the Agency with any technical assistance for the duration of the life of the vehicle and equipment. It is the Agency's prerogative to evaluate the long-term viability of the Contractor and its Subcontractors and Suppliers based upon the criteria set forth in "Qualification Requirements."

Contractor shall place copies of the above manufacturing data in an escrow account to the benefit of the Agency. An escrow agreement is required should the contractor become in poor financial condition; changes ownership; declares bankruptcy or is about to declare bankruptcy; or if the Contractor fails to perform its obligation to either manufacture, support and maintain the product being produced for the Agency. If any of these events occur, the escrow agent shall release the manufacturing data to the Agency so that the Agency can have the products completed, produced and maintained. Contractor also grants Agency full use, royalty free license of the escrowed data and documentation to support the purchased vehicles and equipment. Agency shall not reproduce or modify source code, applications, or documentation for distribution outside of the Agency. (See Appendix B).

SECTION 6: TECHNICAL SPECIFICATIONS

CITY OF FRESNO SPECIFICATIONS

PRODUCT PURCHASE CONTRACT FOR:
Two (2) 40' Low Floor Regular All-Electric Fixed Route Bus

BID FILE NUMBER: 3604

TS 1. General

Comply _____ Do Not Comply _____

- (a) It is the purpose and intent of these Specifications to describe the minimum requirements for **TWO (2) NEW 2019 MODEL YEAR OR NEWER 40' Low Floor Regular All-Electric Fixed Route Bus** to be used by the FAX MAINTENANCE Division of the TRANSPORTATION Department within the City of Fresno.
- (b) All items not specifically mentioned which are required for a complete unit shall be included in the unit bid price.
- (c) All equipment and accessories to be furnished must be new and in current production. All products shall conform in design, strength, quality of material and workmanship to current industry standards.
- (d) Each bid shall be accompanied by a copy of any applicable manufacturer's Published Price List or website, and two copies of the manufacturer's descriptive literature and specifications or website, including a copy of the manufacturer's standard warranty.
- (e) All equipment and accessories shall comply with regulations of the Federal Occupational Safety and Health Administration (OSHA) and the California Occupational Safety and Health Administration (Cal/OSHA), whichever is more restrictive.
- (f) Bidders shall have a minimum of five (5) years' experience and expertise in the area of building buses and electrical propulsion systems, in particular experience with electric bus manufacturing.

If a Bidder is unable to meet the specifications, or comply with any condition described herein, they shall complete the attached Exhibit "B" and submit to the Purchasing Division to the scheduled bid opening. It shall be solely the responsibility of the Bidder to ensure that the Purchasing Division has been notified, prior to the bid opening, of the Bidder's inability to meet the specifications.

Prior to delivery, all equipment shall be completely inspected, and services performed as prescribed by the manufacturer(s).

TS 2. Explanation of Bid Items

Comply _____ Do Not Comply _____

Where specific part numbers/product names are used, either on the bid proposal pages or in these technical conditions, it is not done so to eliminate properly qualified products from competition, but as a method of setting standards for quality and functionality of the items to be purchased.

It is hereby understood and agreed by all bidders that all bids will be based only upon products specified herein by the City. Bidders who bid products not specified or not approved by addendum will not be eligible for award.

The City of Fresno has not specified a preferred brand, make, or model for the following specifications. However all vehicles to be provided by the Bidder shall be of the same make and model for consistency purposes and the need of the City of Fresno to obtain a homogenous Fleet. Mixed and matched vehicles of different years, makes, and models will not be considered for award.

Indicate compliance status by checking "Comply" or "Do Not Comply" on line provided below each main specified title. A reply of "Do Not Comply" will be considered an exception and may render the bidder non-responsive. If neither Comply nor "Do Not Comply" are left blank, it shall mean Bidder is in "Compliance".

TS 3. General Design

Comply _____ Do Not Comply _____

The units shall be an air-conditioned low floor electric transit coaches comprised of a single functional unit. They shall have seating, as further described and shall have doors, and floor configurations suitable for City passenger use. Vehicles shall be supplied with a wheelchair ramp at the entrance and center door and wheelchair positions with restraints.

In all cases, materials must be new and furnished as specified. Where brand names or specific items are used in these specifications, consider the term "reviewed equal" to follow. Wherever such names appear, reviewed equals will be accepted only with the prior written concurrence from the City. All test data required within these specifications shall be submitted to the City prior to delivery of pilot vehicle unless specified otherwise.

The Contractor shall conform to these technical specifications and shall not omit any unit or component or both, part or detail to make these buses ready for service, even though such part or detail is not mentioned in these specifications. In absence of a specification, the Contractor shall adhere to its manufacturing standards. No changes or substitutions are permitted without the prior written consent of the City. This procurement will allow retirement of older buses and expansion of the revenue fleet. The City's overall objective for purchase, design and operation of a new fleet of electric buses shall be to satisfy the following requirements:

- Safe and Reliable in Operation
- Economic to Purchase, Operate and Maintain
- Optimized Performance, Emissions and Fuel Consumption
- Full compliance with all applicable rules, regulations and standards in place at the time of manufacturing

TS 3.1 Bus Design

Comply _____ Do Not Comply _____

The buses shall have a sleek, aerodynamic, modern, and fashionable design that is aesthetically appealing. A raised roof cap shall be designed to run the entire roof of the bus and conform to the contours of the body's sleek, aerodynamic, modern, and fashionable design of the bus. The raised roof cap shall mask the electrical, HVAC system, battery system, and any other roof mounted equipment of the bus. The raised roof cap shall flow seamlessly from the top of the windshield to the rear of the bus. The windows shall be hidden framed and mount flush with the exterior of the bus. All exterior panels

shall have a smooth and seamless look with no visible fasteners. Exterior access doors shall be designed to be functional with a sleek and discrete look.

TS 4. Scope

Comply _____ Do Not Comply _____

Technical specifications define requirements for heavy-duty transit buses, which, by the selection of specifically identified alternative configurations, may be used for both suburban express service and general service on urban arterial streets. Buses shall have a minimum expected life of twelve (12) years or 500,000 miles, whichever comes first, and are intended for the widest possible spectrum of passengers, including children, adults, the elderly and people with disabilities.

TS 5. Definitions

Comply _____ Do Not Comply _____

Agency: City of Fresno – Department of Transportation/FAX

Alternative: An alternative specification condition to the default bus configuration. The City may define alternatives to the default configuration to satisfy local operating requirements. Alternatives for the default configuration will be clearly identified.

Ambient Temperature: The temperature of the surrounding air. For testing purposes, ambient temperature must be between 16°C (50°F) and 38°C (100°F).

Analog Signals: A continuously variable signal that is solely dependent upon magnitude to express information content.

NOTE: Analog signals are used to represent the state of variable devices such as rheostats, potentiometers, temperature probes, etc.

Audible Discrete Frequency: An audible discrete frequency is determined to exist if the sound power level in any 1/3-octave band exceeds the average of the sound power levels of the two adjacent 1/3-octave bands by 4 decibels (dB) or more.

Battery Compartment: Low-voltage energy storage, i.e. 12/24 VDC batteries.

Battery Management System (BMS): Monitors energy, as well as temperature, cell or module voltages, and total pack voltage. The BMS adjusts the control strategy algorithms to maintain the batteries at uniform state of charge and optimal temperatures.

Braking Resistor: Device that converts electrical energy into heat, typically used as a retarder to supplement or replace the regenerative braking.

Burst Pressure: The highest pressure reached in a container during a burst test.

Capacity (fuel container): The water volume of a container in gallons (liters).

Cells: Individual components (i.e., battery or capacitor cells).

City: City of Fresno – Department of Transportation/FAX

Class of Failure:

- C.1 Class 1: Physical Safety; A failure that could lead directly to passenger or driver injury and represents a severe crash situation.
- C.2 Class 2: Road Call; A failure resulting in an in-route interruption of revenue service. Service is discontinued until the bus is replaced or repaired at the point of failure.
- C.3 Class 3: Bus Change; A failure that requires removal of the bus from service during its assignments. The bus is operated to a rendezvous point with a replacement bus.
- C.4 Class 4: Bad Order; A failure that does not require removal of the bus from service during its assignments but does degrade bus operation. The failure shall be reported by driver or inspector.

Code: A legal requirement.

Combination Gas Relief Device: A relief device that is activated by a combination of high pressures or high temperatures, acting either independently or together.

Composite Container for CNG: A container fabricated of two or more materials that interact to facilitate the container design criteria.

Compressed Natural Gas (CNG): Mixtures of hydrocarbon gases and vapors consisting principally of methane in gaseous form that has been compressed for use as a vehicular fuel.

Container: A pressure vessel, cylinder or cylinders permanently manifold together, used to store CNG.

Container Appurtenances: Devices connected to container openings for safety, control or operating purposes.

Container Valve: A valve connected directly to a container outlet.

Contractor, Seller, and Supplier: Shall each mean and refer to each person or other entity awarded a Contract hereunder and named or to be named in the Agreement with the City to furnish the goods or services, or both, to be furnished under the Contract.

Curb Weight: Weight of vehicle, including maximum fuel, oil and coolant; and all equipment required for operation and required by this Specification, but without passengers or operator.

dBA: Decibels with reference to 0.0002 microbar as measured on the "A" scale.

DC to DC Converter: A module that converts a source of direct current from one voltage level to another.

Default Configuration Bus: The bus described if no alternatives are selected. Signing, colors, the destination sign reading list and other information must be provided by the City.

Defueling: The process of removing fuel from a tank.

Defueling Port: Device that allows for vehicle defueling, or the point at which this occurs.

Destroyed: Physically made permanently unusable.

Discrete Signal: A signal that can take only pre-defined values, usually of a binary 0 or 1 nature, where 0 is battery ground potential and 1 is a defined battery positive potential.

DPF: Diesel particulate filter.

Driver's Eye Range: The 95th-percentile ellipse in SAE Recommended Practices J941, except that the height of the ellipse shall be determined from the seat at its reference height.

Energy Density: The relationship between the weight of an energy storage device and its power output in units of watt-hours per kilogram (Wh/kg).

Energy Storage System (ESS): A component or system of components that stores energy and for which its supply of energy is rechargeable by the on-vehicle system (engine/regenerative braking/generator) or an off-vehicle energy source.

Fill Pressure for CNG: The pressure attained at the actual time of filling. Fill pressure varies according to the gas temperatures in the container, which are dependent on the charging parameters and the ambient conditions. The maximum dispensed pressure shall not exceed 125 percent of service pressure.

Flow Capacity: For natural gas flow, this is the capacity in volume per unit time (normal cubic meters/minute or standard cubic feet per minute) discharged at the required flow rating pressure.

Fuel Line: The pipe, tubing or hose on a vehicle, including all related fittings, through which natural gas passes.

Fusible Material: A metal, alloy or other material capable of being melted by heat.

Fire Resistant: Materials that have a flame spread index less than 150 as measured in a radiant panel flame test per ASTM-E 162-90.

Fireproof: Materials that will not burn or melt at temperatures less than 2000°F.

Free Floor Space: Floor area available to standees, excluding the area under seats, area occupied by feet of seated passengers, the vestibule area forward of the standee line, and any floor space indicated by manufacturer as non-standee areas, such as the floor space "swept" by passenger doors during operation. Floor area of 1.5 sq. ft. shall be allocated for the feet of each seated passenger protruding into the standee area.

Fuel Management System: Natural gas fuel system components that control or contribute to engine air fuel mixing and metering, and the ignition and combustion of a given air-fuel mixture. The fuel management system would include, but is not limited to, reducer/regulator valves, fuel metering equipment (e.g. carburetor, injectors), sensors (e.g., main throttle, wastegate).

GAWR (Gross Axle Weight Rated): The maximum total weight as determined by the axle manufacturer, at which the axle can be safely and reliably operated for its intended purpose.

Gross Load: 150 lbs. for every designed passenger seating position, for the operator, and for each 1.5 sq. ft. of free floor space.

GVW (Gross Vehicle Weight): Curb weight plus gross load.

GVWR (Gross Vehicle Weight Rated): The maximum total weight as determined by the vehicle manufacturer, at which the vehicle can be safely and reliably operated for its intended purpose.

High Pressure: Those portions of the CNG fuel system that see full container or cylinder pressure.

High Voltage (HV): Greater than 50 V(AC and DC).

Hose: Flexible line.

Hybrid: A vehicle that uses two or more distinct power sources to propel the vehicle.

Hybrid System Controller (HSC):Regulates energy flow throughout hybrid system components in order to provide motive performance and accessory loads, as applicable, while maintaining critical system parameters (voltages, currents, temperatures, etc.) within specified operating ranges.

Hybrid Drive System (HDS): The mechanical and/or electromechanical components, including the engine, traction motors and energy storage system, which comprise the traction drive portion of the hybrid propulsion system.

Intermediate Pressure: The portion of a CNG system after the first pressure regulator, but before the engine pressure regulator. Intermediate pressure on a CNG vehicle is generally from 3.5 to 0.5 MPa (510 to 70 psi).

Inverter: A module that converts DC to and from AC.

Labeled: Equipment or materials to which has been attached a label, symbol or other identifying mark of an organization, which is acceptable to the authority having jurisdiction and concerned with product evaluation, which maintains periodic inspection of production labeled equipment or materials, and by whose labeling the manufacturer indicates compliance with appropriate standards or performance in a specified manner.

Leakage: Release of contents through a Defect or a crack. See *Rupture*.

Line: All tubes, flexible and hard, that carry fluids.

Liner: Inner gas-tight container or gas container to which the overwrap is applied.

Local Regulations: Regulations below the state level.

Low-Floor Bus: A bus that, between at least the front (entrance) and rear (exit) doors, has a floor sufficiently low and level so as to remove the need for steps in the aisle between the doors and in the vicinity of these doors.

Low Voltage (LV): 50 V or less (AC and DC).

Lower Explosive Limit: The lowest concentration of gas where, given an ignition source, combustion is possible.

Maximum Service Temperature: The maximum temperature to which a container/cylinder will be subjected in normal service.

Metallic Hose: A hose whose strength depends primarily on the strength of its metallic parts; it can have metallic liners or covers, or both.

Metering Valve: A valve intended to control the rate of flow of natural gas.

Module: An assembly of individual components

Motor (Electric): A device that converts electrical energy into mechanical energy.

Motor (Traction): An electric motor used to power the driving wheels of the bus.

Operating Pressure: The varying pressure developed in a container during service.

Operator's Eye Range: The 95th-percentile ellipse defined in SAE Recommended Practice J941, except that the height of the ellipse shall be determined from the seat at its reference height.

Physical Layer: The first layer of the seven-layer International Standards Organization (ISO) Open Systems Interconnect (OSI) reference model. This provides the mechanical, electrical, functional and procedural characteristics required to gain access to the transmission medium (e.g., cable) and is responsible for transporting binary information between computerized systems.

Pipe: Nonflexible line.

Pressure Relief Device (PRD): A pressure and/or temperature activated device used to vent the container/cylinder contents and thereby prevent rupture of an NGV fuel container/cylinder, when subjected to a standard fire test as required by fuel container/cylinder standards.

NOTE: Since this is a pressure-activated device, it may not protect against rupture of the container when the application of heat weakens the container to the point where its rupture pressure is less than the rated burst pressure of the relief device, particularly if the container is partially full.

Power: Work or energy divided by time

Power Density: Power divided by mass, volume or area.

Power Plant: The engine along with related ignition, fuel, and transmission components of the bus.

Propulsion System: System that provides propulsion for the vehicle proportional to operator commands. Includes, as applicable, engine, transmission, traction motors, the hybrid drive system (HDS), energy storage system (ESS), and system controllers including all wiring and converter/inverter.

Real-Time Clock (RTC): Computer clock that keeps track of the current time.

Regenerative Braking: Deceleration of the bus by switching motors to act as generators, which return vehicle kinetic energy to the energy storage system.

Rejectable Damage: In terms of NGV fuel containers/cylinders, this is damage as outlined in CGA C-6.4, "Methods for External Visual Inspection of Natural Gas Vehicle Fuel Containers and Their Installations," and in agreement with the manufacturer's recommendations.

Retarder: Device used to augment or replace some of the functions of primary friction based braking systems of the bus.

Rupture: Sudden and unstable damage propagation in the structural components of the container resulting in a loss of contents. See *Leakage*.

Seated Load: 150 lbs. for every designed passenger seating position and for the operator.

SLW (Seated Load Weight): Curb weight plus seated load.

Serial Data Signals: A current loop based representation of ASCII or alphanumeric data used for transferring information between devices by transmitting a sequence of individual bits in a prearranged order of significance.

NOTE: An example is the communication that takes place between two or more electronic components with the ability to process and store information.

Service Pressure: The settled pressure at a uniform gas temperature of 21°C (70°F) and full gas content. It is the pressure for which the equipment has been constructed, under normal conditions. Also referred to as the nominal service pressure or working pressure.

Settled Pressure: The gas pressure when a given settled temperature, usually 21°C (70°F), is reached.

Settled Temperature: The uniform gas temperature after any change in temperature caused by filling has dissipated.

Solid State Alternator: A module that converts high-voltage DC to low-voltage DC (typically 12/24 V systems).

Sources of Ignition: Devices or equipment that because of their modes of use or operation, are capable of providing sufficient thermal energy to ignite flammable compressed natural gas-air mixtures when introduced into such a mixture, or when such a mixture comes into contact with them.

Special Tools: Tools that are proprietary to a specific part, manufacturer, brand, or model that are necessary to service, repair, or maintain a component and not normally stocked by the City.

Specification: A particular or detailed statement, account or listing of the various elements, materials, dimensions, etc. involved in the manufacturing and construction of a product.

Standard: A firm guideline from a consensus group. Standards referenced in "Section 6: Technical Specifications" are the latest revisions unless otherwise stated.

Standee Line: A line marked across the bus aisle to designate the forward area that passengers may not occupy when the bus is moving.

State of Charge (SOC): Quantity of electric energy remaining in the battery relative to the maximum rated amp-hour (Ah) capacity of the battery expressed in a percentage. This is a dynamic measurement used for the energy storage system. A full SOC indicates that the energy storage system cannot accept further charging from the engine-driven generator or the regenerative braking system.

Stress Loops: The "pigtailed" commonly used to absorb flexing in piping.

Structure: The basic body, including floor deck material and installation, load-bearing external panels, structural components, axle mounting provisions and suspension beams and attachment points.

Thermally Activated Gas Relief Device: A relief device that is activated by high temperatures and generally contains a fusible material.

NOTE: Since this is a thermally activated device, it does not protect against over-pressure from improper charging practices.

Transit Coach: A regular fixed route bus used for general service.

Wheelchair: A mobility aid belonging to any class of three- or four-wheeled devices, usable indoors, designed for and used by individuals with mobility impairments, whether operated manually or powered. A "common wheelchair" is such a device that does not exceed 30 in. in width and 48 in. in length measured 2 in. above the ground, and does not weigh more than 600 lbs. when occupied.

TS 6. Referenced Publications

Comply _____ Do Not Comply _____

The documents or portions thereof referenced within this specification shall be considered part of the requirements of the specification. The edition indicated for each referenced document is the current edition, as of the date of the City of Fresno's issuance of this specification.

TS 7. Legal Requirements

Comply _____ Do Not Comply _____

The Contractor shall comply with all applicable federal, state and local regulations. These shall include but are not be limited to ADA, FMVSS, and Buy America provisions, as well as state and local accessibility, safety and security requirements. Local regulations are defined as those below the state level.

Buses shall meet all applicable FMVSS regulations and shall accommodate all applicable FMCSR regulations in effect at the location of the City and the date of manufacture.

In the event of any conflict between the requirements of these specifications and any applicable legal requirement, the legal requirement shall prevail. Technical requirements that exceed the legal requirements are not considered to conflict.

The Manufacturer shall provide the City with verification of compliance to the regulations and requirements of these specifications during engineering design reviews to be conducted prior to production.

The Contractor and the City will agree on a Contract Deliverable Requirements List (CDRL) that defines all the documentation required from the manufacturer to verify compliance to the City specifications during the pre-production meetings.

TS 8. Overall Requirements

Comply _____ Do Not Comply _____

The Contractor shall ensure that the application and installation of major bus subcomponents and systems are compliant with all such subcomponent vendors' requirements and recommendations. Contractor and the City shall identify subcomponent vendors that shall submit installation/application approval documents with the completion of a pilot or lead bus. Components used in the vehicle shall be of heavy-duty design and proven in transit service. All components, subcomponents, features, color schemes, designs, layouts, and aesthetics provided on the pilot or lead bus shall be incorporated in all buses provided under this contract to the City at no additional cost to the City or with a change order by the City.

Components used in the vehicle shall be of heavy-duty design and proven in transit service. Whenever a specific trade or product name is used within this specification, the following statement applies "...or reviewed equal with the same standards of quality, design and performance." All requests for reviewed equals must be submitted to the Agency for review.

The selection of, routing, material and location of items such as piping, cabling, wiring, etc. shall be obvious to a design plan in an effort to avoid interference, abrasion and unnecessary lengths, bundles, etc. Routing shall be in parallel and securement via composite split pinch blocks, P clamps are discouraged and tie straps prohibited. Overall, the bus shall be assembled per an inclusive design plan, to include selection, location and application of components, routing and securement of harnesses, piping, hoses, hoses, fittings, fasteners, etc. The following general guidelines shall apply unless specifically addressed otherwise:

- The use/length of flexible piping shall be minimized.
- The quantity of fittings shall be minimized (unnecessary use of bushings, adapters, etc.) and SAE O-ring / JIC flare type fittings used as available in place of NPT. NPT fittings shall not be used in any part of the fuel system prior to obtaining the RTC's written consent.
- Fasteners shall not be of excessive length and critical fasteners subject to loosening shall incorporate a locking mechanism, such as, pinned, safety wire, thread locking adhesive, interference nuts, etc.
- Piping and all cables shall be routed in a parallel fashion and be retained by split type mounting blocks using pinch bolts, therefore the use of "P" clamps shall not be allowed without RTC final approval, and the use of traditional tie straps shall not be permitted.
- Wherever possible electrical harnesses shall be in a fan-out design for ease of individual electrical harness identification.

TS 8.1 Weight

Comply _____ Do Not Comply _____

It shall be a design goal to construct each bus as light in weight as possible without degradation of safety, appearance, comfort, traction or performance.

Buses at a capacity load shall not exceed the tire factor limits, brake test criteria or structural design criteria.

TS 8.2 Capacity

Comply _____ Do Not Comply _____

The vehicle shall be designed to carry the Gross Vehicle Weight, which shall not exceed the bus GVWR. The vehicle shall not exceed the individual gross axle weight rating (GAWR) at curb weight plus gross load.

TS 8.3 Seating Capacity

Comply _____ Do Not Comply _____

The seating capacity shall be designed to carry the maximum number of seated and standee passengers, which shall not exceed the bus's GVWR. The seating arrangement shall be preapproved by the procuring agency. A floor plan meeting these requirements shall be submitted during the approved equal process for approval.

TS 8.4 Service Life

Comply _____ Do Not Comply _____

The minimum useful design life of the bus in transit service shall be at least twelve (12) years and 500,000 miles. It shall be capable of operating at least 40,000 miles per year, including the 12th year.

TS 8.5 Maintenance and Inspection

Comply _____ Do Not Comply _____

Scheduled maintenance tasks shall be related and shall be grouped in maximum mileage intervals in accordance with the manufacturer's recommended preventative maintenance schedule (along with routine daily service performed during the fueling operations). Scheduled maintenance actions shall not be required at intervals of less than 7,000 miles except for routine daily service. Higher levels of scheduled maintenance tasks shall occur at even multiples of not less than 7,000 miles.

Test ports, as required, shall be provided for commonly checked functions on the bus, such as air intake, exhaust, hydraulic, pneumatic, charge-air and engine cooling systems.

The coach manufacturer shall give prime consideration to the routine problems of maintaining the vehicle. All coach components and systems, both mechanical and electrical, which will require periodic physical Work or inspection processes shall be installed so that a minimum of time is consumed in gaining access to the critical repair areas. It shall not be necessary to disassemble portions of the coach structure and/or equipment such as seats and flooring under seats in order to gain access to these areas. Each coach shall be designed to facilitate the disassembly, reassembly, servicing or maintenance, using tools and equipment that are normally available as standard commercial items.

Requirements for the use of unique specialized tools will be minimized. The body and structure of the coach shall be designed for ease of maintenance and repair. Individual panels or other equipment that may be damaged in normal service shall be repairable or replaceable. Ease of repair shall be related to the vulnerability of the item to damage in service.

Contractor shall provide all special tools required for maintaining this equipment. Said list shall be submitted as a supplement to the Pricing Schedule. Tools such as compartment door keys, bellows gauges and other tools that are required for maintenance and inspections shall be furnished for each coach.

TS 8.6 Interchangeability

Comply _____ Do Not Comply _____

Unless otherwise agreed, all units and components procured under this Contract, whether provided by Suppliers or manufactured by the Contractor, shall be duplicates in design, manufacture and installation to ensure interchangeability among buses in each order group in this procurement. This interchangeability shall extend to the individual components as well as to their locations in the buses. These components shall include, but are not limited to, passenger window hardware, interior trim, lights, light lenses and seat assemblies. Components with non-identical functions shall not be, or appear to be, interchangeable.

Any one component or unit used in the construction of these buses shall be an exact duplicate in design, manufacture and assembly for each bus in each order group in this Contract. Contractor shall identify and secure approval for any changes in components or unit construction provided within a Contract.

In the event that the Contractor is unable to comply with the interchangeability requirement, the Contractor must notify the City and obtain the City's prior written approval, including any changes in pricing.

City shall review proposed product changes on a case-by-case basis and shall have the right to require extended warranties to ensure that product changes perform at least as well as the originally supplied products.

TS 8.7 Deliverables

Comply _____ Do Not Comply _____

TS 8.7.1 Training

The Contractor will have at least one qualified instructor who will be available at the City's property at a time and for a duration mutually agreed to by both parties. Instructor(s) will conduct schools and advise the personnel of the City on the proper operation and maintenance of the equipment. The Contractor also will provide visual and other teaching aids (such as manuals, slide presentations and literature) for use by the City's own training staff, which becomes the property of the City.

Contractor shall provide an adequate educational program for the City or authorized representative's personnel for each bus order to insure satisfactory operation, servicing and maintenance of the equipment furnished by contractor.

The instructor of the course shall be well trained and educated on the equipment, components, and software that they are conducting the course for, and be manufacturer trained instructors where applicable. Instruction shall also include manufacturer's recommendations for test frequency, limits and methods, including instructions required, where applicable. When methods of access, removal, dismantling or application are not self-evident, the instruction shall cover these matters.

At the conclusion of the classroom instruction the Contractor shall furnish to the City TWO (2) complete sets of lesson plans, classroom notes, films, slides, tapes, and any other materials used in presenting the courses.

The extent of instruction in the Contractor's and sub-contractor's shops for instruction of supervisory and/or City instructors shall be at the discretion of the Contractor.

All training provided will include an exam with a certificate with the specific courses listed on the certificates. The certificates shall not be in general overall and copies of completion certificates, completed exams and copies of certificates shall be provided to the City upon each course for each and every City employee who completed the course.

Contractor shall provide training to City of Fresno as mentioned in the Training Schedule below for each purchase order with the Contractor at no cost to the City. An initial training and familiarization of the buses shall be provided to the City upon the first bus delivery. Training shall be provided six to

twelve (6-12) months after the acceptance of the final bus delivered per purchase order of a minimum purchase of six (6) buses, as stated in SP 5.2 Delivery Schedule. The training shall be provided on site at the City of Fresno – Department of Transportation/FAX Maintenance facility. Contractor shall assume all cost associated with this training. Training must include diagnosing, repairing, troubleshooting, familiarization, maintenance, and the correct use of testing equipment for all components and software needed to maintain the all product, equipment and vehicles provided by the Contractor. Time shall be divided equally between classroom and actual bus hands on work where applicable. Course curriculum needs are to be discussed by the City and Contractor prior to the development of the Contractor's curriculum, hours and course may vary per bus order depending on the needs of the City. Contractor is required to submit a curriculum to City for review and approval prior to scheduling classes. Instructor(s) shall conduct classes/sessions and advise the personnel of the City on the proper operation and maintenance of the equipment. The Contractor also shall provide visual and other teaching aids (such as, but not limited to manuals, slide presentations and literature) for use by the City's own training staff, which become the property of the City.

The Contractor shall develop or facilitate the development of training curriculum. The curriculum will be discussed during pre-production meetings and submitted to the City no later than 30 days prior to course dates. The curriculum shall be designed specifically for the City's bus orders and shall incorporate all special equipment ordered on the bus, including:

2 Jacking, Lifting, and Towing

Training Subject		Hours
Standard Bus Maintenance		
1	Introduction	1
2	Jacking, Lifting, and Towing	2
3	Depot Charger	2
4	High Voltage System/Safety	4
5	Low Voltage System	4
6	Control System/Diagnostics	8
7	Propulsion System	1
8	Suspension	1
9	Air System	1
10	Steering	1
11	Cooling System	2
12	Preventative Maintenance	3
13	Intro to Door system	1
14	Intro to HVAC System	1
Standard Fast Charging Maintenance		
15	Introduction	1
16	HV Safety	4
17	Maintenance Procedures	4
18	Calibrating Procedure	1
19	Troubleshooting	2
20	Fast Charger Components	2
Standard Other Training		
21	Bus Familiarization and Introduction	16
22	Using the Depot Charger	2
23	EMS and First Responder	8
24	Operator Training	24
Vendor Training		
25	Door System	16
26	HVAC	16
27	Structural Composite Repair	24
28	Depot Charger Maintenance and Repair	8

TS 8.7.2 Spare Components and Parts Deliverables

Spare Components and Parts Deliverables		Quantity Due
Low Voltage Electrical Power		
1	Converter, DC-DC	1
2	Contactora 350 AMP	2
3	Vanner Battery Equalizer	1
4	Battery, 12V, 100AH, Group 31	2
High Voltage Electrical Power		
5	Contactora, GX26,600A, 800 VDC	2
6	Fuse, 20AMP, 600VAC, FERRAZ SHAWMUT (ATMR20)	2
7	VFD, Dual 30kw Output	1
Drivers Work Place		
8	Actuator, Reverse Selection Switch	1
9	Actuator, Drive Selection Switch	1
10	Actuator, Neutral Selection Switch	1
11	Actuator, Front Door Control Switch	1
12	Actuator, Rear Door Control Switch	1
13	Switch, No Push Button, Red/Green, Led, 6-Pos (Fast Charge Only)	1
14	Switch, Mushroom (Fast Charge Only)	1
15	SWITCH, FLOOR, DIMMER, HEADLAMP	2
16	Driver Seat Complete w/ Mounting Hardware and Bracket	1
Wipers and Washers		
18	Wiper Motor, 2 Speed	1
19	Wiper Arm, Windshield, CS	1
20	Wiper Arm, Windshield, SS	1
21	Wiper, Blade	1
22	Wiper Blade, Windshield, 1000MM	1
Electrical Cabinet		
23	Relay 10A	2
24	Relay 35A	2
Front Suspension and Steering		
25	Spring, Air, Front, 1T19L-5 BELLOW	2
26	Shock Absorber Front	2
Rear Suspension		
27	Spring, Air, Rear	2
28	Shock Absorber Rear	2
Ride Height		
29	Sensor, Height, Suspension, 6" Arm	2
Exterior Lighting		
30	Light, Tail Lamp, Rear	2
31	Light, Back Up Lamp, Rear	2
32	Light, Rear Turn Signal, Clear Lens, Amber Led	2
33	Light, Red, Side Marker	4
34	Light, Yellow, Side Marker	8
Air System		
35	Modulator, M-32, 24V	2
36	Valve, Double Check, DC-4	1
37	Valve, Single Check, SC-3	1
38	Transducer, Pressure	1
39	Solenoid, Pneumatic, Exhaust, High Flow, Suspension	2
Coolant System		
40	Pump, Water, Catalyst	3
Entrance Doors		
41	Glass, Entrance Door	1

Spare Components and Parts Deliverables		Quantity Due
42	Panel, Assy, Left, Entrance Door	1
43	Panel Assy, Right, Entrance Door	1
Exit Doors		
44	Glass, Exit Door	1
45	Panel Assy, Left, Exit Door	1
46	Panel Assy, Right, Exit Door	1
Bus Body		
47	Gas Spring, Lower Side Hatch	3
48	Gas Spring, Clamshell	3
49	Gas Spring, Lower Hatch Rear	3
50	Spring, Gas, 8" Stroke, 20LB	2
51	Latch, Scoop	1
52	Latch , Compression, Square Key	1
Exterior Attachments		
53	Wheel Well Flare, Front	2
54	Wheel Well Flare, Rear	2
55	Mirror, CS	2
56	Mirror, SS	2
Windows And Windshield		
57	Windshield, Front	1
58	Rear Window	1
59	Driver Window	1
60	Driver Window	1
61	Gasket, Windshield	1
Modules		
62	Computer, Central, Multiplex, ZR32-A, 24V	1
63	Circuit Breaker, Type III, 5A	1
64	Circuit Breaker, Type III, 10A	1
65	Circuit Breaker, Type III, 15AMP	1
66	Circuit Breaker, Type III, 20A	1
67	Controller, Node, MUX (Multiplex), MUX2-B, 12V, 24	3
Consumables		
68	Oil, Compressor, Hydrovane HPO	3
69	Air Filter, Large, Air Compressor	1
70	Air Filter, Small, Air Compressor	1
71	Desiccant, Pack	10
72	TA366-3056 Desiccator	5
73	Filter, Air, Defroster	1
74	Filter, Air, Foam , HVAC	1

TS 8.7.3 Tooling and Equipment Deliverables

Tooling and Equipment Deliverables		Quantity Due
1	Manufacturer Diagnostic Tool - Main diagnostic tool for bus, lifetime subscription	1
2	DIAGNOSTIC LAPTOP COMPUTER - Troubleshooting on the bus	1
	a. Windows 7 based 32 bit operating system	
	b. Intel Core 2 Duo T7300 / 2.0 GHz	
	c. L2 cache - 4.0 MB	
	d. DVD drive	
	e. No web camera	
	f. 2 GB RAM	

Tooling and Equipment Deliverables		Quantity Due
	g. 500 GB solid state hard drive	
	h. Bluetooth 2.0 EDR, 802.11a/b/g	
	i. Ethernet	
	j. Trusted Platform Module (TPM 1.2) Security Chip	
3	026024 USB LINK 026025 ADAPTER	1
4	USB-Link (WiFi) + J1962 Adaptor - Used with the Manufacturer Diagnostic Tool	1
5	ABS Programming Tool	1
6	Arc Flash jacket and over pant, AS1200 face shield, hard hat, Salisbury storage bag and safety glasses. (Size S- 3XL)	1
7	HV Glove Kit (size 8-12)	1
8	Red Lockout Padlock	2
9	Grip-Cinching Cable Lockout, Red, 8 ft.	2
10	Lift Table, Battery	1
11	Insulated Crimper	1
12	Deutsch Crimper	1
13	MUX Crimper	1
14	Deutsch Pin Removal Tool	1
15	Plastic fuse puller	1
16	Molex Electrical Pin Extractor Tool	1
17	Delphi Pin Extractor	1
18	DB9/OBD2 adapter - Troubleshooting on the bus or charger	1
19	Sulzer Mixpac 400mL Manual Cartridge Gun - For minor replacement or repair of bonded components	1
20	Sulzer Mixpac 400mL Pneumatic Cartridge Gun - For large replacement or repair of bonded components	1
21	80 PC Master Electricians Insulated Tool Set In Rolling Water Tight Traveling Tool Box.	1

TS 8.8 Technical/Service Representatives

Comply _____ Do Not Comply _____

The Contractor shall, at its own expense, have one or more competent technical service representatives available on request to assist the City in the solution of engineering or design problems within the scope of the specifications that may arise during the warranty period. This does not relieve the Contractor of responsibilities under the provisions of "Section 7: Warranty Requirements."

TS 8.9 Support Requirements

Comply _____ Do Not Comply _____

The contractor shall submit with the Bid a list containing the name, address, and telephone number of all representatives responsible for assisting the City, as well as the location for off-site repair and maintenance of the buses to be supplied.

TS 8.10 Service Manuals

Comply _____ Do Not Comply _____

Contractor is responsible to provide two (2) sets of any service, mechanical, diagnostic, electrical, and parts manuals for any and all components that are included in the building of the City's buses, including but not limited to propulsion system, HVAC, fire suppression, battery system, bus/component wiring, etc. Manuals should show wire coloring. A set of two (2) manuals shall be provided with each bus order; each set shall include at least one (1) electronic versions of each manual.

TS 8.11 Operating Environment

Comply _____ Do Not Comply _____

The bus shall operate normally under all environmental conditions usually occurring in the City's service area. The bus shall achieve normal operation in ambient temperature ranges of 10° F to 120° F, at relative humidity between 5 percent and 100 percent, and at altitudes up to 5,000 ft. above sea level. Degradation of performance due to atmospheric conditions shall be minimized at temperatures below 0° F, above 120° F or at altitudes above 5,000 ft. Altitude requirements above 5,000 ft. will need separate discussions with the engine manufacturer to ensure that performance requirements are not compromised. Speed, gradability and acceleration performance requirements shall be met at, or corrected to, 77° F, 29.31 in. Hg., and 2,200 ft. dry air per SAEJ1995. Performance degradation at conditions other than the test standard shall not exceed 1 percent for each 3° F and 4 percent for each 1,000 feet of altitude above the standard. Propulsion system and drive train shall provide power to enable the bus to meet the defined acceleration, top speed, and gradeability requirements. Sufficient excess power shall be available to operate all accessories.

TS 8.12 Noise

Comply _____ Do Not Comply _____

TS 8.12.1 Interior Noise

The combination of inner and outer panels and any material used between them shall provide sufficient sound insulation so that a sound source with a level of 80 dBA measured at the outside skin of the bus shall have a sound level of 65 dBA or less at any point inside the bus. These conditions shall prevail with all openings, including doors and windows, closed and with the engine and accessories switched off.

The bus-generated noise level experienced by a passenger at any seat location in the bus shall not exceed 80 dBA. The operator area shall not experience a noise level of more than 75 dBA. Measurements of interior noise levels shall be taken in accordance with SAEJ2805.

TS 8.12.2 Exterior Noise

Airborne noise generated by the bus and measured from either side shall not exceed 80 dBA at fifty (50) feet pass-by under full power acceleration when operated at 0 to 35 mph at curb weight. The maximum noise level generated by the bus pulling away from a stop at full power shall not exceed 80 dBA at fifty (50) feet. The bus-generated noise at curb idle shall not exceed 65 dBA at ten (10) feet. If the noise contains an audible discrete frequency, a penalty of 5 dBA shall be added to the sound level measured. The Contractor shall comply with the exterior noise requirements defined in local laws and ordinances identified by the City and SAEJ366.

The bus manufacturer shall provide certification, in writing, that interior dBA measurements for each bus are in compliance with the interior sound test requirements prior to final acceptance of each unit delivered.

TS 8.13 Respect for the Environment

Comply _____ Do Not Comply _____

In the design and manufacture of the bus, the Contractor shall make every effort to reduce the amount of potentially hazardous waste. In accordance with Section 6002 of the Resource Conservation and Recovery Act, the Contractor shall use, whenever possible and allowed by the specifications, recycled materials in the manufacture of the bus

TS 8.14 Omission

Comply _____ Do Not Comply _____

Notwithstanding the provision of drawings, technical specifications, or other data by the City, the Contractor shall have the responsibility of supplying all parts and details required to make the Vehicle complete and ready for service even though such details may not be specifically mentioned in the drawings and specifications. Other items that are installed by the City shall not be the responsibility of the Contractor unless they are included in this contract.

TS 9. Materials/Accessories Responsibility

Comply _____ Do Not Comply _____

The Contractor shall be responsible for all material and accessories used, whether the same are manufactured by the Contractor or purchased from supplier. This provision excludes tires, fare boxes and other equipment leased or supplied by the City, except insofar as such equipment is damaged by the failure of a part or component for which the Contractor is responsible, or except insofar as the damage to such equipment is caused by the Contractor during the manufacture of the Vehicles.

TS 9.1 Materials

Comply _____ Do Not Comply _____

All equipment furnished and the parts thereof shall be the manufacturer's latest listed and published stock models, except where modification is specifically permitted or required. The equipment and parts shall meet all the applicable requirements of the specifications.

All materials used in the manufacturing of the Vehicles shall be new unless otherwise specified. All design, workmanship, and materials shall at all times and places be subject to the inspection of the City's designated representative(s). Should an item fail to meet his/her approval, it shall be forthwith made good, replaced, or corrected (as the case may be) by the Contractor at its own expense.

All materials used in construction of the Vehicle and all its parts shall conform in all respects to the American Society of Testing Materials, Society of Automotive Engineers, or similar association standards. Materials used shall be of first quality and shall be exactly duplicated in manufacture, design and construction in each of the Vehicles.

It shall be the design objective to eliminate from the coaches all materials that are or may become hazardous to passengers, operators, or maintenance personnel. Of particular concern are materials that produce toxic smoke or gases when heated, possibly due to an accidental fire or when bodywork using welding equipment or cutting torches is necessary. No parts on the coach shall contain lead, asbestos or PCBs. The Contractor shall provide for City approval, prior to production, the safety data sheets (SDS) of any hazardous materials or fluids that must be used in the construction, operation or maintenance of the vehicle.

All lumber shall be thoroughly kiln dried, free from knots and checks and shall be clear straight grain, dressed on all sides.

All painted aluminum sheets shall be thoroughly cleaned and coated on the outside with epoxy chromate protective paint (or reviewed equal) prior to assembly in Vehicle.

All joints shall be protected by application of 1/64 in. thick double faced, foam tape or adhesive and specified undercoating (or reviewed equal) at assembly.

All 5/8 in. o.d. and smaller bolts, nuts and washers, shall be zinc, cadmium plated, or phosphate coated to prevent corrosion.

TS 10. Principles of Design

Comply _____ Do Not Comply _____

All systems requiring servicing shall be equipped with approved self-contained check devices. The preferred check device for hydraulic system reservoir(s) shall be a dip stick that is clearly marked to show service level and fluid.

If, in the opinion of the City any part or component is not readily accessible or removable, the City may require the Contractor to correct these deficiencies at the Contractor's own expense, before acceptance.

All systems shall be designed to allow quick and efficient operation of the unit. Electrical, hydraulic, and other systems shall be operational within a minimum amount of temperature stabilization, and

accumulator or system build-up. From a "cold start" condition to operationally ready shall require not more than two (2) minutes.

TS 11. Workmanship

Comply _____ Do Not Comply _____

Workmanship shall be of the best quality and shall conform in all respects to the best practice in the industry.

Welding procedures, welding materials, and qualifications of operators shall be in accordance with the standards of the ASTM, ISO, DIN, MSZ and/or the American Welding Society. All welds shall be uniform in appearance and free of irregularities after welding to present a smooth finished appearance. During the welding process, all weld contact surfaces shall be free of scale, grease and paint.

Where non-anodized metal is riveted or bolted to metal, contact surfaces shall be thoroughly cleaned with high temperature cleaning agent, double rinsed, and coated with critical corrosion zinc chromate primer (or reviewed equal). All rivets shall completely fill the holes. All bolts or rods passing through wood shall be cadmium plated (or reviewed equal). Where wood and wood are placed together, both shall be coated with powdered aluminum and spar varnish or linseed oil and titanium oxide, or other approved sealing compound.

All wood shall be filled, sealed and finished.

All steel and aluminum body parts which are to be painted shall be thoroughly cleaned and double rinsed, or one (1) water rinse and one (1) neutralizing rinse using metacote concentrate to inhibit corrosion and insure proper paint adhesion. Excess joint sealer shall be removed prior to priming with heavy-duty zinc chromate primer. Underside of all concealed metal panels shall be undercoated with Mortell Company Emulsion Asphalt #MBC-1605 undercoating compound (or reviewed equal). External roof joints may be protected with a resin type undercoating material. Particular care should be exercised to see this material is sprayed into all corners, crevices and pockets.

All design factors shall take into consideration the safety of the passengers, operators and maintenance personnel. Items requiring safety consideration in design include, but are not limited to:

- Elimination of sharp corners and edges
- Locations for handrails and stanchions
- Impact yielding handrails on seats
- No obstructions in aisles
- Implementation of Federal safety standards, Intensity and distribution of interior lighting
- Elimination of interior driver area windshield glare
- Exterior lighting at doorways
- Steps
- Elimination of pinch hazards on interior and exterior assemblies
- Implementation of ADA requirements
- Body construction
- Side impact barriers, Padding on seat back tops, Non-skid step nosing
- Acceleration and Braking
- Floor hatches

TS 12. Dimensions

TS 12.1 Physical Size

Comply _____ Do Not Comply _____

With exceptions such as exterior mirrors, marker and signal lights, bumpers, fender skirts, washers, wipers, ad frames, cameras, object detection systems, bicycle racks, feelers and rub rails, the bus shall have the following overall dimensions as stated below at static conditions and design height.

TS 12.2 Bus Length

Comply _____ Do Not Comply _____

For ease of use, the following tolerances will be allowable for each given bus length. Bus length is determined as the measurement from bumper to bumper.

- **40ft bus:** 40 ft., +/- 3 in.

TS 12.3 Bus Width

Comply _____ Do Not Comply _____

Body width shall be 102 in. Maximum (+0, -1 in.).

TS 12.4 Bus Height

Comply _____ Do Not Comply _____

Maximum overall height shall be 135 in., including all rigid, roof-mounted items such as A/C, exhaust, battery system and cover, etc.

TS 12.5 Step Height

Comply _____ Do Not Comply _____

The step height shall not exceed 14 in. measured from the road surface to the top edge of the front and rear doorway centerline. Once the bus is completely kneeled, it shall not exceed 10 in. measured from the road surface to the top edge of the front and rear doorway centerline. The two steps to accommodate a raised aisle floor in the rear of the bus shall not exceed 8 in. per steps.

TS 12.6 Underbody Clearance

Comply _____ Do Not Comply _____

The bus shall maintain the minimum clearance dimensions as shown in the Figure 1 "Transit Bus Minimum Road Clearance" as defined in Society of Automotive Engineers (SAE) Standard J689, regardless of load up to the gross vehicle weight rating.

TS 12.7 Ramp Clearances

Comply _____ Do Not Comply _____

The approach angle is the angle measured between a line tangent to the front tire static loaded radius arc and the initial point of structural interference forward of the front tire to the ground.

The departure angle is the angle measured between a line tangent to the rear tire static loaded radius arc and the initial point of structural interference rearward of the rear tire to the ground.

The breakover angle is the angle measured between two lines tangent to the front and rear tire static loaded radius and intersecting at a point on the underside of the vehicle that defines the largest ramp over which the vehicle can roll.

TABLE 1

Default Breakover Angle

Angle	40 ft. Bus
Approach	8.6 deg. (min.)
Front breakover	7.0 deg. (min.)
Departure	7.5 deg. (min.)

TS 12.8 Ground Clearance

Comply ____ Do Not Comply ____

Ground clearance shall be no less than 9 in. (8 inches at jacking pad), except within the axle zone and wheel area.

Axle zone clearance, which is the projected area between tires and wheels on the same axial centerline, shall be no less than 5.5 inches.

Wheel area clearance shall be no less than 8 in. for parts fixed to the bus body and 6 in. for parts that move vertically with the axles.

FIGURE 1

Transit Bus Minimum Road Clearance

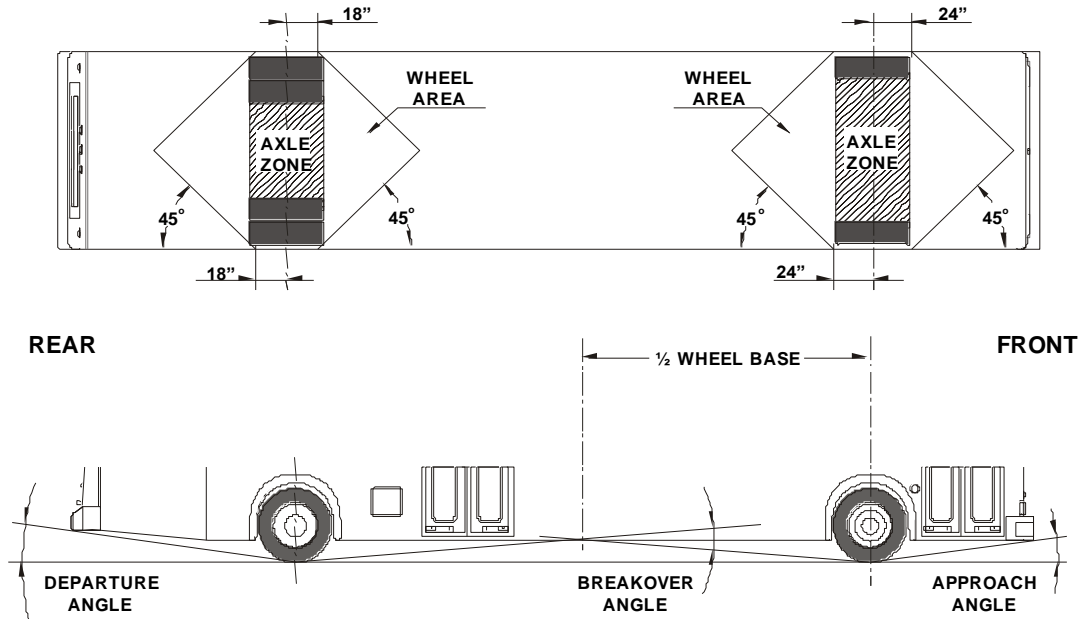

TS 12.9 Floor Height

Comply ____ Do Not Comply ____

Height of the step above the street shall be no more than 16.5 inches measured at the centerline of the front doorway and 17 inches at the centerline of the rear doorway. The floor may be inclined along the longitudinal axis of the bus, and the incline shall be less than 3 1/2 degrees off the horizontal except locally at the doors where a maximum 5 degrees slope toward the door is allowed.

TS 12.10 Interior Headroom

Comply ____ Do Not Comply ____

Headroom above the aisle and at the centerline of the aisle seats shall be no less than 78 in. in the forward half of the bus tapering to no less than 74 in. forward of the rear settee. At the centerline of the window seats, headroom shall be no lower than 65 inches. Headroom at the back of the rear bench seat may be reduced to a minimum of 56 in., but it shall increase to the ceiling height at the front of the seat cushion. In any area of the bus directly over the head of a seated passenger and positioned where a passenger entering or leaving the seat is prone to strike his or her head, padding shall be provided on the overhead paneling.

TS 12.11 Aisle Width

Comply ____ Do Not Comply ____

The minimum clear aisle width between pairs of transverse seats with all attached hardware shall be at least 22 in.

The aisle width between the front wheelhouses shall be at least 38 in., and the entire area between the front wheelhouses shall be available for passengers and mobility aid devices.

TS 13. Fire Safety

Comply _____ Do Not Comply _____

The bus shall be designed and manufactured in accordance with all applicable fire safety and smoke emission regulations. These provisions shall include the use of fire-retardant/low-smoke materials, fire detection systems, fire suppression, firewalls/bulkhead, and facilitation of passenger evacuation. In recognition of the high exhaust temperatures experienced, the construction of areas directly surrounding the exhaust stack shall be done using fire-retardant/low-smoke materials. Design of this area shall be such that any material ejected from the exhaust stack will not cause ignition or degradation of the surfaces in the immediate vicinity surrounding the stack.

The selection of fire retardant materials, as available, shall extend to fluids as well, such as hydraulic oil, power steering fluid, fluids used as transfer media at heat exchangers, etc. Particular attention to this requirement shall apply to fluids typically used in areas of high heat (engine compartment, exhaust piping/muffler area turbo charger/turbine). There shall be no hydraulic lines or hoses that run above an ignition source, which includes the battery box.

All materials used in the construction of the Passenger Compartment of the bus shall be in accordance with the Recommended Fire Safety Practices defined in FTA Docket 90, dated October 20, 1993. Materials entirely enclosed from the passenger compartment, such as insulation within the sidewalls, need not comply. In addition, smaller components and items, such as at grab rails, switch knobs and small light lenses' shall be exempt from this requirement.

TS 13.1 Materials

Comply _____ Do Not Comply _____

All materials used in the construction of the passenger compartment of the bus shall be in accordance with the Recommended Fire Safety Practices defined in FMVSS 302. or with the Recommended Fire Safety Practices defined in FTA Docket 90-A, dated October 20, 1993, whichever is more advantageous. Materials entirely enclosed from the passenger compartment, such as insulation within the sidewalls and sub-floor, need not comply. In addition, smaller components and items, such as seat grab rails, switch knobs, small light lenses, door seals, window seals, steering wheel, steering column and escape hatches shall be exempt from this requirement.

TS 13.2 Fire Protection

Comply _____ Do Not Comply _____

The passenger and propulsion system compartments shall be separated by a bulkhead(s) which shall, by incorporation of fireproof materials in its construction, be a firewall. This firewall shall preclude or retard propagation of an engine compartment fire into the passenger compartment. Only necessary openings shall be allowed in the firewall, and these shall be fireproof. Any passageways for the climate-control system air shall be separated from the engine compartment by fireproof material. Piping through the bulkhead shall have copper, brass, or fireproof fittings sealed at the firewall with copper or steel piping on the forward side. Wiring may pass through the bulkhead only if connectors or other means are provided to prevent or retard fire propagation through the firewall. The conduit and bulkhead connectors shall be sealed with fireproof material at the firewall. Engine access panels in the firewall shall be fabricated of fireproof material and secured with fireproof fasteners. These panels, their fasteners, and the firewall shall be constructed and reinforced to minimize warping of the panels during a fire that will compromise the integrity of the firewall. The gas detection system will operate independently of the fire suppression system.

TS 13.3 Automatic Fire Suppression System (AFSS)

Comply _____ Do Not Comply _____

No fire suppression system shall be required so long as the battery management system is capable of thermally monitoring the internal temperature with redundant sensors internal to the battery packs. If the temperatures become high enough to affect performance, the Battery Management System shall be required to de-rate power until the temperature is reduced. If the temperatures were to continue rising, the control system shall be required to disable the vehicle.

TS 13.3.1 General Requirements

A dry chemical, pre-engineered fire suppression system shall be furnished and installed for the protection of the vehicle/equipment. This system shall be approved and listed for use at minus (-) 65° F (-54° C) to plus (+) 180° F (66° C) on mobile or self-propelled equipment by Factory Mutual Research Corporation (FMRC). The fire extinguishing system shall consist of extinguisher(s), nozzle(s) and a distribution system designed for vehicle applications that shall be installed in accordance with the AFSS manufacturer installation manual. The extinguisher shall be of the stored pressure type and consist of a high-speed valve, DOT approved cylinder and pressure gauge. Each fire extinguisher shall weigh less than sixty (60) lbs. when filled with agent.

Engine compartment shall be equipped with an Amerex Automatic Fire Suppression System or reviewed equal AFSS complete with fire sensors, protection panel, vehicle interface(s), and fire extinguishing system shall be provided. The system shall operate on 12 or 24 VDC. The engine compartment, battery compartment, fuel storage tank(s) located on the roof of the vehicle, and other areas likely to contain leaking fuel shall be protected.

The manufacturer shall provide all necessary equipment for routine testing and calibration of fire suppression system for the City or authorized representative. Final installation design of the fire suppression system shall be subject to City's approval.

The manufacturer shall provide all necessary training and manuals (Maintenance and Parts) for City or authorized representative's personnel, to ensure complete working knowledge of the system.

The completed system shall be tested and certified by the supplier. The test shall determine that the system has been properly installed and will function as intended. The test data shall be provided to the City prior to delivery of the buses. A Certification Report shall be provided prior to final acceptance for each vehicle that includes a detail of the tests performed, drawings and or photographs of the component locations.

TS 13.3.2 AFSS Fire Extinguishing Agent

The extinguisher shall be charged with a minimum of 22 lbs. of ammonium phosphate based, multi-purpose Class ABC dry chemical and pressurized to a minimum of 350 psi. This agent shall be approved for use with the system specified herein by FMRC. The agent is no-toxic. Non-carcinogenic, and is classified as a "nuisance dust" by OSHA standards.

TS 13.3.3 AFSS Agent Cylinder

Agent Cylinder shall be the stored pressure type. They shall be constructed of welded steel and must conform to Department of Transportation (DOT) specifications 4BW, and must be marked as such. The hydrostatic retest intervals for these cylinders shall be a minimum of twelve (12) years. Cylinders shall be modular, with each having its own discharge piping and nozzles. Operating pressure for the cylinders shall be 350 psig. A gauge, protected by a gauge guard, shall be provided to indicate proper pressurization of agent cylinder. The agent cylinder shall be equipped with a forged brass valve assembly. The valve shall retain and release extinguishing agent and expellant pressure by means of a spring loaded sealing stem. The valve shall be configurable for actuation by an electric control head. No replacement parts, such as burst disc, shall be required to recharge the agent cylinder following discharge.

The valve shall incorporate a pressure gauge, which is clearly visible when fire extinguisher(s) are installed on the coach. Provisions shall be provided on the extinguisher bracket or other suitable

location to stow the anti-recoil cap and/or other devices used to ensure safe transportation of the extinguisher when removed from the Vehicle.

TS 13.3.4 AFSS Nozzles

Nozzles shall be brass, and be of a design approved by FMRC for use with the vehicle suppression system specified herein. Nozzles shall be located to protect specific hazards on the vehicle. All nozzles are to be fitted with dust caps that, upon system actuation, are displaced to allow full chemical flow. The caps are to be constructed so that upon displacement they do not drop into a fire hazard area where they can contribute as fuel to an in process fire.

Nozzles shall be of the type to provide both total flooding and local application coverage. Nozzle coverage shall be modular to provide a minimum single nozzle total flooding coverage of 244 cu. ft. with or local application coverage of 900 sq. in. Nozzles shall be combined with appropriate agent cylinders to yield 2, 4, 6, or 8 nozzle combinations.

TS 13.3.5 AFSS Hoses and Fittings

Fittings shall be galvanized malleable or ductile iron, black or galvanized steel, stainless steel, copper, or brass. Cast iron fittings shall not be used. Hoses shall be, at a minimum, single wire braided, rubber hose conforming to and marked as SAE 100 R5 or SAE 100 R1.

TS 13.3.6 AFSS System Actuation

An electric control head shall accomplish actuation of the agent cylinder valve(s) for distribution of the extinguishing chemical. Electrical current for actuation of an electric actuator shall be provided by the vehicle electrical system. The system shall also use an internal rechargeable back up battery, which shall provide sufficient electrical current to actuate the system for a minimum period of twenty-four (24) hours in the event the vehicle electric system power is interrupted. Actuating the electric control head shall be accomplished by the manual depression of an electric switch (button) or by the automatic signal from heat sensing thermostats.

TS 7.3.6.1 AFSS Control Panel

The control panel shall be located in easy view of the operator but shall not impede his view of the road. A single connection interface shall be provided to interface to the AFSS harness. The use of shielded cables is not allowed. Location of control panel to be reviewed by the City.

The protection panel shall incorporate operator controls for:

- a) Alarm silence
- b) Testing the visual and audible indications
- c) Delay the automatic engine stop and/or extinguisher discharge
- d) Reset the system after a fire.

The Control Panel shall provide outputs for the following vehicle interfaces:

- Engine/Fuel Shutdown –Field adjustable for immediate or delayed (15 or 30 seconds). Delayed setting to be set to 30 second activation, additionally the system shall have the ability (optional feature) for External Warning IE: activates external alarm upon control panel alarm signal.
- The Control Panel shall provide an audible and visual indication upon loss of continuity of the detection or extinguisher circuits. The visual indication for the extinguisher circuit shall be easily identified from the visual signal for the detection circuit for ease of fault location.

TS 7.3.6.2 Fire Detection

Devices approved for use by FMRC, as Heat Actuated Fire Detectors shall accomplish detection of fires. The detectors shall be normal open and shall be capable of carrying sufficient amperage for the purpose of firing the electric actuator.

TS 13.3.7 AFSS Installation

Installation of fire suppression systems into the City vehicles shall be performed prior to delivery of the vehicles to the City. All work to be performed by certified technicians in fire suppression installation, as determined by the manufacturer.

TS 13.4 Safety Equipment

Comply _____ Do Not Comply _____

Safety equipment shall be provided, which shall be easily accessible to the operator, shall be securely mounted with durable box and/or retaining equipment to the interior of the bus, and located in City approved locations. The safety equipment shall consist of the following:

- One (1) each, Five (5) lb., "ABC "class, Fire Extinguisher
- One (1) set of three (3) red emergency reflectors.
- One (1) Bodily fluid containment kit
- Two (2) Large wheel chocks

The general-purpose 5-pound ABC extinguisher and mounting bracket shall be provided. The City will determine the location at the pre-production meeting.

TS 13.4.1 Fire Extinguisher Certification

All installation, inspection, maintenance and repair of portable fire extinguishers and fixed extinguishing systems shall meet all federal, state, and local requirements.

TS 14. Vehicle Performance

Comply _____ Do Not Comply _____

Vehicle proposed shall be capable of performing with minimum defects in City's transit operating environment for the life of the vehicle, 12 year or 500,000 mile vehicle design. The vehicles will be used at elevations ranging from one hundred feet (100 ft.) to five hundred feet (500 ft.) and in ambient temperatures from twenty degrees (20°) to one hundred and thirty degrees (130°) Fahrenheit.

The wheelbase shall be sufficient to allow for minimal vibration, bounce or jouncing. A test consisting of a coach traveling at twenty (20) mph passing over an isolated bump in the road, to be created by a standard two (2) inch by four (4) inch block that all wheels go over, shall not indicate more than a peak of 2 g on an accelerometer positioned at any point on the floor of the coach.

TS 14.1 Power Requirements

Comply _____ Do Not Comply _____

The propulsion system shall be sized to provide sufficient power to enable the bus to meet the defined acceleration, top speed and gradability requirements, and operate all propulsion-driven accessories using actual road test results and computerized vehicle performance data.

TS 14.2 Top Speed

Comply _____ Do Not Comply _____

The bus shall be capable of achieving a top speed of 55 mph on a straight, level road at GVWR with all accessories operating, and shall be governed at a top speed of 55 mph. The bus shall be capable of safely maintaining the vehicle speed according to the recommendations by the tire manufacturer. Manufacturer shall supply City with data if there is a variance between peak performance and sustained vehicle performance.

TS 14.3 Gradability

Comply _____ Do Not Comply _____

Gradability requirements shall be met on grades with a dry commercial asphalt or concrete pavement at GVWR with all accessories operating. The propulsion system and drive train of each and every bus

proposed by Contractor shall enable the bus to achieve and maintain a speed of 40 mph on a 2.5 percent ascending grade, 15 mph on a 10 percent ascending grade, and 10 mph on a 15 percent ascending grade continuous. Manufacturer shall supply City with data if there is a variance between peak performance and sustained vehicle performance.

TS 14.4 Acceleration

Comply _____ Do Not Comply _____

A maximum average acceleration rate of at least 0.06 g shall be achieved, at GVWR, between 0 mph and 15 mph. Acceleration measurement shall commence when the accelerator is depressed. Jerk, the rate of change of acceleration, shall be minimized throughout the acceleration/deceleration range and shall be no greater than 0.3 g/sec. This requirement shall be achieved regardless of operator actions. The Contractor shall provide performance scans to the City based on the City's specific drivetrain configuration.

The acceleration shall meet the requirements in Table 2 below and shall be sufficiently gradual and smooth to prevent throwing standing passengers off-balance. Acceleration measurement shall commence when the accelerator is depressed.

TABLE 2
 Maximum Start Acceleration Times on a Level Surface¹

Speed (mph)	Maximum time (seconds)
10	5
20	10
30	18
40	30
50	60
Top speed	

1. Vehicle weight = GVWR

The propulsion and braking systems shall meet the performance requirements of the Duty Cycle.

Braking application and performance shall remain consistent regardless of electric storage system state of charge (SOC) or other variances related to regenerative braking.

The system shall be programmable to allow optimization of acceleration and deceleration rate. Performance may be affected when reprogramming. The manufacturer shall supply the new performance data.

TS 14.5 Operating Range

Comply _____ Do Not Comply _____

The operating range of the coach shall be designed to meet the operating profile as stated in TS 15. Fuel Economy (Design Operating Profile).

TS 14.5.1 Electric

The bus shall be supplied with a battery system capable a holding a minimum of 660 kWh and a minimum useable or operating range of the bus with a full state of charge (SOC) when run on the FTA ABD Cycle of 250 miles of operation. On a signal full state of charge (SOC), without charging on route or pulling the bus off route to charge, the bus shall be capable of operating continuously for no less than 250 miles or 10 hours. The Contractor, with its Bid, shall provide energy consumption calculations (motor, speed, bus weight, energy capacity (kWh), energy demand (kW/mile), number of passengers, etc.) to support its claim of meeting the 250 miles required range or 10 hours of operation.

The bus shall be configured to interface with a plug-in charger. The acceptable plug-in chargers are ASE J1772 or J1772 CCS. The charge rate shall be a minimum 125 kW, 875 VDC and bring the battery system of two buses charging simultaneously from a fully depleted state to a full state of charge (SOC) in no longer than four and a half (4.5) hours.

TS 15. Fuel Economy (Design Operating Profile)

Comply _____ Do Not Comply _____

Test results from the Altoona fuel economy tests, or other applicable test procedures shall be provided to the Agency. Results shall include vehicle configuration and test environment information. Fuel economy data shall be provided for each design operating profile. The design operating profile is assumed to be defined by the Bus Research Testing Center at Altoona, Pennsylvania ("Altoona") fuel duty cycle which includes simulated central business district, arterial, and commuter courses.

Altoona fuel economy tests shall be run on these four duty cycles using maximum auxiliary loads and GVRW. Results shall be reported in kWh per mile.

Duty Cycles (average speed):

- Manhattan: 6.8 mph
- Orange County: 12.7 mph
- UDDS: 19 mph
- Idle time

TS 16. Propulsion System

Comply _____ Do Not Comply _____

The bus shall be powered by an all-electric zero emission propulsion system. Function and operation of the bus shall be transparent to the bus operator and passengers. The propulsion system shall comply with applicable local, state and/or federal emissions and useful life requirements. The propulsion system shall comply with local, state and federal (maintenance) and other applicable sections.

The propulsion system shall have a design life of not less than 500,000 miles without replacement or major service. The OEM shall ensure that the bus structure can successfully accept the installation of the propulsion system and be operated on the stated duty-cycle for a period of 12 years without a structural failure. Components of the drive motor, energy management, control, and regenerative system shall be designed to operate for not less than 12 years and/or 500,000 miles without replacement or major service. The lifetime estimate and mileage intervals are based upon the design operating profile.

The all-electric zero emission propulsion system shall be rated for the GVWR or greater of the bus.

TS 16.1 Propulsion System Specifications

Comply _____ Do Not Comply _____

The propulsion system provided with each bus by shall be sized for the appropriate bus size and powertrain/running gear configuration to comply with performance measures set by the City in TS 14.1 Power Requirements.

TS 16.2 Propulsion System Service

Comply _____ Do Not Comply _____

The PM motor shall be designed to operate for not less than 300,000 miles without major failure or significant deterioration. Components of the control system shall be designed to operate for not less than 150,000 miles without replacement or major service.

The propulsion system shall be arranged so that accessibility for all routine maintenance is ensured. No special tools, other than dollies and hoists, shall be required to remove the propulsion system or any subsystems. However, the Agency shall recognize that properly rated test equipment and safe

electrical work practices are essential when servicing high-voltage electric components. The Contractor shall provide all specialty tools and diagnostic equipment required for maintaining the propulsion system in accordance with the Special Tools List. All drive system accessories requiring service or replacement shall be easily removable. Two mechanics shall be able to remove and replace the propulsion system assembly in less than 6 total combined person-hours. The accessories and any other component requiring service or replacement shall be easily removable and independent of the propulsion system removal.

TS 16.3 Propulsion System Compartment

Comply _____ Do Not Comply _____

The propulsion system compartment shall be painted with a high quality high heat resistant paint and shall have sufficient ventilation to maintain temperatures to prevent heat damage to components, lines, and hoses. All propulsion system compartment plumbing shall be done with stainless steel lines welded or double flared.

All lines shall be constructed of material that will resist failures due to temperature conditions of the propulsion system compartment and shall be routed and clamped, with rubber coated P-clamps around such lines, to prevent abrasion. Propulsion system shall be equipped with a guard(s) and label(s) to indicate hazardous sections and moving parts (pulleys, belt, fans, etc.). Location shall be of easy convenient access for maintenance and service technicians.

TS 16.4 Propulsion System Mounting

Comply _____ Do Not Comply _____

The propulsion system supports shall be fabricated and strong enough to support the propulsion system, including g-forces at all points. The propulsion system supports shall position the propulsion system properly in the chassis, and bolt to the propulsion system mounting points on the coach frame or unibody. Welding or cutting the coach frame or unibody is not acceptable. Rubber vibration isolators of the proper load rating and durometer rating shall be used to prevent excessive vibration and roll of the propulsion system. All bolts, locknuts, and washers used in the propulsion system mounting system shall be SAE J429, Grade 8, zinc plated. Driveline angles are to be within acceptable limits as specified by SAE standards.

TS 16.5 Traction Motor

Comply _____ Do Not Comply _____

The traction motor shall be able to provide and recover kinetic energy as well as retard mechanical momentum (regenerative braking). The propulsion system shall utilize an appropriately sized permanent magnet (PM) traction motor for the appropriate bus size and powertrain/running gear configuration to comply with performance measures set by the City in TS 14.1 Power Requirements. Traction motor speed control shall be continuously variable and not rely on shift points.

TS 16.5.1 Mounting

All traction motor mounting shall be mechanically isolated to minimize transfer of vibration to the body structure and provide a minimum clearance of 0.75 in. Mounts shall control the movement of the traction motor so as not to cause strain in piping and wiring connections to the traction motor.

TS 16.6 Jerk

Comply _____ Do Not Comply _____

Jerk, the rate of change of acceleration measured at the centerline, floor level of the bus, should be minimized throughout the shift of each range application and should be no greater than 0.3g/sec. for duration of a quarter-second or more.

TS 17. Transmission (If Applicable)

Comply _____ **Do Not Comply** _____

The transmission shall be a multiple-speed, automatically shifted transmission with electronic controls. A torque converter and retarder are not needed. Gross input power, gross input torque and rated input speed shall be compatible with the traction motor. The transmission must be designed to operate for no less than 300,000 miles on the design operating profile without replacement or major service. The transmission must be easily removable without disturbing the traction motor and accessible for service.

The electronic controls must be capable of transmitting and receiving electronic inputs and data from other drivetrain components and of broadcasting that data to other vehicle systems. Communication between electronic drivetrain components and other vehicle systems shall be made using the communications networks. Electronic controls must be compatible with 24 V power distribution, provide consistent shift quality, and compensate for changing conditions, such as variations in vehicle weight and engine power. At a minimum, drivetrain components consisting of the motor, transmission and anti-lock braking systems must be powered to ensure data communication among components exists when the vehicle ignition is switched to the "on" position.

The electronically controlled powertrain and vehicle controller must have on-board diagnostic capabilities, be able to monitor functions, store and time-stamp out-of-parameter conditions in memory, and communicate faults and vital conditions to service personnel. The transmission must contain built-in protection software to guard against severe damage. The on-board diagnostic system shall be required to trigger a visual alarm to the driver when the electronic control unit detects a malfunction.

A moderate brake pedal application is required by driver to engage forward and reverse range from the neutral position to prevent sudden acceleration of the bus from a parked position.

The transmission must be an automatically shifted unit with manual transmission architecture, i.e. gears, shafts and shift collars but with no clutches, or torque converter, therefore there is not a need to monitor the fluid on an ongoing basis. The fluid will remain at a constant level between specified fluid change intervals.

TS 18. Regenerative Braking

Comply _____ **Do Not Comply** _____

The bus shall have a regenerative braking system to aid in the reduction of wear on the brakes and to help extend the range of the vehicle through energy recapture. The vehicle will employ regenerative braking as the accelerator pedal is completely released. Regenerative braking shall be additionally increased as the brake pedal is applied which shall also increase service brake application.

TS 19. Propulsion Control Systems

Comply _____ **Do Not Comply** _____

The propulsion system's electronic management system shall monitor operating conditions and provide instantaneous adjustments to optimize both propulsion system and bus performance.

The drive motor shall be equipped with an electronically controlled management system, compatible with 12-volt power distribution. The motor control system shall be capable of transmitting and receiving electronic inputs and data from other drivetrain components, and broadcasting that data to other vehicle systems. Communication between electronic drivetrain components and other vehicle systems shall be made using the communications networks.

The battery electric drive system shall have onboard diagnostic capabilities able to monitor vital motor functions, store and time stamp parameter conditions in memory, and communicate faults and vital conditions to service personnel. Diagnostic reader device connector ports, suitably protected against dirt and moisture, shall be provided in the operator's area. The onboard diagnostic system shall inform the operator via visual and/or audible alarms when out of parameter conditions exist for vital engine functions. The on-board diagnostic system shall have capabilities for storing hard and soft codes and

processing data and provide detailed information/reports on various aspects of fleet usage. The information shall be retrievable via cabling or wireless transmission to a laptop.

The motor drive shall protect the drive system against progressive damage. The system shall monitor conditions critical for safe operation and automatically de-rate power and/or speed and initiate motor shutdown as needed. The on-board diagnostic system shall trigger a visual and audible alarm to the operator when the motor control unit detects a malfunction and the engine protection system is activated.

Automatic shutdown shall only occur when parameters established for the functions below are exceeded:

- Over Temp
- Inverter Fault
- Over Voltage
- Broken Wire
- Loss of Electrical Communications
- Communications Safety
- No redundant bus manufacturer and/or component manufacturer "detection and shutdown" circuits. By default, the component manufacturer's software shall be used to record fault codes.

TS 19.1 Electric Vehicle System Controller (EVSC)

Comply _____ Do Not Comply _____

The electric vehicle system controller shall be equipped with a control system that complies with SAE J1708 "Recommended Practice for Serial Data Communication Between Microprocessor System In Heavy-Duty Vehicle Applications". The electric vehicle system controller should be capable of diagnostics, archive of failure data, adaptive learning and programming via a laptop PC in a "Windows" environment. This capability should extend to time stamping of failure data, running in a real time mode for road testing and data storage. When an impairment occurs in any area, the microprocessor must signal the operator through a properly labeled light on the dashboard. Trouble codes logged by the electric vehicle system controller shall be permanently retained in the module's memory until removed with proper equipment. The EVSC shall be accessible from two diagnostic reader ports, one positioned in operator's area and one in propulsion system control box.

The propulsion system shall be equipped with an electronically controlled management system, compatible with either 12 or 24 volt power distribution. The propulsion control system shall be capable of transmitting and receiving electronic inputs and data from other propulsion system components and broadcasting that data to other vehicle systems. Communication between electronic propulsion system components and other vehicle systems shall be made using the communications networks. The system shall be programmable to allow optimization of programmable features.

The electric vehicle system controller shall contain a backup microprocessor unit that takes over propulsion system controls in case a fault develops with the main microprocessor system. There shall be no mechanical controls of linkage to the EVSC. The system shall include a check propulsion system light (amber) and a stop propulsion system light (red) to be mounted on the dashboard in view of the operator. These lights shall be activated by the propulsion system control module. The data readers shall be capable of troubleshooting beyond isolating to function.

In the event of an automatic shutdown, the propulsion system control module shall activate a programmed shutdown of the propulsion system according to the following schedule:

PERCENT OF THROTTLE	SECONDS AFTER FAULT DETECTED
100	0

84	5
68	10
53	15
40	17

Propulsion system shutdown shall occur 30 seconds after fault detection. An override shall be provided to allow an additional 30 seconds of propulsion system operation, each time the override is used, before final shutdown.

Engine shutdown due to low coolant level. A low coolant probe shall be provided with an amber telltale light incorporated into the warning system which shall only activate a shutdown mode if the warning (amber) light is illuminated for more than thirty (30) seconds.

The programmed engine shutdown system shall also be programmed to be activated by receiving a signal from the transmission due to high oil temperature.

A control shall be available to the operator which, when constantly depressed, will allow the operator to delay the automatic shutdown for thirty (30) seconds, but not the Fire Suppression System activation and alarm system.

TS 19.1.1 Transmission Control System

The electronic controls must be capable of transmitting and receiving electronic inputs and data from other drivetrain components and of broadcasting that data to other vehicle systems. Communication between electronic drivetrain components and other vehicle systems shall be made using the communications networks. Electronic controls must be compatible with 24 V power distribution, provide consistent shift quality, and compensate for changing conditions, such as variations in vehicle weight and motor power. At a minimum, drivetrain components consisting of the motor, transmission and anti-lock braking systems must be powered to ensure data communication among components exists when the vehicle ignition is switched to the “on” position.

The electronically controlled powertrain and vehicle controller must have on-board diagnostic capabilities, be able to monitor functions, store and time-stamp out-of-parameter conditions in memory, and communicate faults and vital conditions to service personnel. The transmission must contain built-in protection software to guard against severe damage. The on-board diagnostic system shall be required to trigger a visual alarm to the driver when the electronic control unit detects a malfunction.

TS 19.2 Energy Storage System (ESS) Control System

Comply _____ Do Not Comply _____

The propulsion system’s electronic management system shall monitor operating conditions and provide instantaneous adjustments to optimize both propulsion system and bus performance.

The ESS control system shall be a hierarchical control with the energy storage module (ESM) acting as the interface and lead controller to the rest of the battery system. This module shall communicate on the main vehicle CAN bus to interface with the cooling, powertrain, charge and other systems. This module shall also communicate on the separate battery CAN bus with all of the individual packs. The main controller interface shall exchange information about battery input and output capability as well as cooling needs and diagnostic information.

The ESS battery pack controllers shall gather the current information as well as pack voltage, cell voltage, and temperature information. The master controller shall use this information to compute system limits, determine health, and ultimately apply system-wide boundaries on use. All of the contactors in the system shall have feedback to allow the system to know if there is a potential for high voltage to be present when it shouldn’t be. The temperature measurements in the ESS battery pack must be redundant in nature. The ESS battery packs must also include sensors to detect moisture and monitor the current distribution between the pack in order to confirm it is within an acceptable range.

The ESS control system shall provide system discharge limits to ensure that the lowest cell never goes below its minimum and the system charge limit to ensure that the highest cell never goes above its maximum. The system shall also comprehend current imbalance between the packs, temperatures throughout all of the packs, moisture, and isolation detection.

TS 20. Energy Storage System (ESS)

Comply _____ Do Not Comply _____

Energy storage system shall be of a commercial design capable of operating in the City transit environment. The total nominal system storage capacity shall be suitable for the desired operating profile and range set by the City in TS 14. Vehicle Performance and TS 15. Fuel Economy (Design Operating Profile). An overview of the design and performance of the Energy Storage System (ESS) shall be provided to the Agency. The ESS shall be capable of operating in the Agency transit environment. The ESS shall be designed, sized, and selected to ensure that the vehicle performance specifications, compatibility with charging, and other related requirements are met or exceeded, bearing in mind cost benefit and reliability variables as they relate to the characteristics of the different battery types. The power source for the vehicle shall be derived from established battery technology that has a field-proven track record of safe, reliable, and durable operation in similar applications.

The primary charging of the energy storage system shall be accomplished by conductive charging as needed to meet the required duty cycle. The charging shall be provided from a stationary charging station via a mechanical or manual conductive interface, i.e., plug. The energy storage system shall also make use of regenerative braking. The Energy Storage System shall comply with UN/DOT 38.3 requirements for lithium batteries or similar standards for non-lithium batteries.

The Contractor shall deliver the buses with an installed, fully-charged, functioning ESS. The ESS shall be fully formed, installed and tested in accordance with the battery manufacturer's recommended practices. The ESS design, including containers, module bracing systems, thermal-management systems, battery management systems, watering/venting systems, interconnections, fusing, and traction-controller and charger interfaces should be completely described in the bid.

The bid shall include a detailed analysis of expected battery performance in the Design Operating Profile. The bid should also include a comprehensive statement of the warranty terms relating to the battery, including explanation of all disclaimers within the warranty. The charge cycle and cycle life should be stated in the bid and a life cycle cost analysis of the proposed battery system in the specified application should be provided.

The battery system shall be capable of withstanding the high current and voltage profiles necessary to accomplish daily recharge events without reducing the life of the battery.

A thermal management system separate from the cooling system of the traction motor shall be provided to ensure optimal life and performance of the ESS over the environmental operating range.

TS 20.1 Energy Storage System (ESS) Safety

Comply _____ Do Not Comply _____

The ESS battery packs shall be located outside the passenger compartment and in a position outside of a direct side or rear impact zone. Additionally, the ESS batteries shall be load distributed within the bus to equalize weight between the wheels on the same axles and to achieve appropriate weight distribution between axles so as not to adversely affect handling of the bus.

The bus body shall be purpose-design and constructed to ensure passengers and the operator will not be exposed to electrical current either in normal operation or in the event of a vehicle accident. Analysis and test data shall be provided to the Agency. The ESS shall be designed and constructed to prevent gassing or fumes from the ESS from entering the interior of the bus, i.e., a vent path to the exterior.

Bids shall include complete descriptions of all safety standards followed in the design and manufacture of the battery system, safety testing procedures used to validate the safety of battery operation in this application, and documented results of safety testing to confirm that standards have been met.

TS 20.2 Battery Management System (BMS)

Comply _____ Do Not Comply _____

As a minimum, the battery management system (BMS) must perform the following functions:

The BMS system must be capable of monitoring the voltage level of cells within each battery pack. The BMS must be able to read and store individual battery or block voltages at a frequency of 1 data point per block every 15 seconds. The system must also monitor battery pack temperatures using no fewer than 2 thermocouples placed in and around each battery pack sampled at the same 4 samples per minute frequency.

The BMS system must be capable of communicating when a battery fault (as defined by the battery manufacturer) has occurred and must be able to identify and communicate the faulty battery in order to perform maintenance.

The BMS system must be capable of engaging prudent safety interlocks when an unsafe battery condition has been detected.

The BMS system must be able to monitor the battery state-of charge and update a gauge viewed by the operator at least once every 15 seconds.

The BMS system must be able to communicate all data to the bus level information system for storage and communication.

TS 20.3 Battery Thermal Management

Comply _____ Do Not Comply _____

Battery thermal management must be powered from an onboard source at all times. Thermal management must be continuously monitored at all times with appropriate safety interlocks installed to react to adverse conditions.

Battery temperatures must never exceed the manufacturer's recommended range during operation in the design operating profile and specified ambient conditions. Battery cooling must be sufficient to prevent the temperature from exceeding the battery manufacturer's recommended maximum temperature when the ambient temperature is above 105 degrees F for a period of 16 hours.

TS 21. Shop/Depot Charging Connection

Comply _____ Do Not Comply _____

The bus shall be able to interface and receive a charge from shop/depot charging equipment with a charge rate of 125 kW. The connection interface shall be separate and independent of the pantograph connection interface. The shop/depot charger connection interface shall be located next to the fuse box on the rear curbside and a second one on the rear street side of the bus to allow for charging on either side. The charger interface shall have its own access door.

A Dual 125 kW DC shop/depot charger capable of bring the battery system of two buses charging simultaneously from a fully depleted state to a full state of charge (SOC) in no longer than four and a half (4.5) hours. After connection to the shop/depot charger, it shall be possible to initiate and control charging from both the bus and the charger control panel. The charger shall feature multiple selectable power level settings and be capable of remote setting for the purposes of power management. The bus shall monitor SOC, Temperature and other critical parameters and only allow charging if parameters are in within acceptable limits. The shop/depot charger shall also include full protective earth grounding, ground fault monitoring and high-voltage isolation monitoring. The charging equipment shall be fully UL/CSA certified as required by jurisdiction. Shop/depot chargers shall be rated for indoor or

outdoor installation per local electrical codes. Charger shall operate at full power in any ambient temperatures normally experienced at installation location. Shop/depot charger shall have the capability of being centrally controlled by master controller including charge initiation and charge power adjustments.

TS 21.1 Bus Charging Requirements

Comply _____ Do Not Comply _____

The coach shall be able to charge with a commercially available plug-in charger that uses the North American automotive standard for DC plug-in charging, SAE J1772 CCS Type 1 standard charging protocol. There shall be a minimum of one (1) charge receptacle on the bus located at the rear, curb-side of the vehicle.

TS 21.2 Plug-In Charger Requirements

Comply _____ Do Not Comply _____

The plug-in charger(s) must comply with SAE J1772 CCS Type 1 standard for plug-in charging. The charger(s) must be able to charge the coach from 0% State of Charge to 100% State of Charge, full state of charge (SOC) in under four (4) hours.

TS 22. Cooling & Thermal Management Systems

Comply _____ Do Not Comply _____

The Engineered Machined Products (EMP) cooling package is the standard for the City's bus fleet and shall be the system provided. The cooling/thermal management systems shall be of sufficient size to maintain all drive system fluids at safe, continuous operating temperatures during severe transit duty cycles, with accordance to ambient conditions as specified in TS 8.11 Operating Environment and in accordance with the propulsion system manufacturers' temperature requirements during the most severe transit duty cycles possible with the coach loaded to GVWR and with ambient temperatures up to 130° degrees Fahrenheit. The cooling/thermal management systems should sense the temperatures of the operating fluids and if above or below safe operating conditions, take corrective actions. The fan control system shall be designed with a fail-safe mode of "fan on".

The cooling system shall have an ambient capacity of at least 130° F with 50/50 mix of ethylene glycol/distilled or deionized water which complies with TMC RP-329 "Type A", suitable for extended service life comparable to O/H life of engine. Cooling system shall be able to meet or exceed all manufacturer's cooling requirements in the extreme conditions of the San Joaquin Valley of California (Central California Valley). The cooling system software shall have the ability of monitor system operation and to identify faults, with written description of fault codes. Water hoses shall be silicone hose, or reviewed equal, with stainless steel clamps having combination screw and hex head.

TS 22.1 Propulsion System Thermal Management

Comply _____ Do Not Comply _____

The transmission shall be equipped with a standalone oil to air cooler mounted next to the transmission.

The drive motor shall be cooled by a liquid-based cooling system that does not permit boiling or coolant loss during operation. The cooling fan shall be temperature controlled, preventing the drive motor from exceeding manufacturer's recommended operating temperatures. The temperature-controlled fan shall idle or not be driven when the coolant temperature falls below the minimum level recommended by the engine manufacture. Air vent valves shall be fitted at high points in the cooling system unless it can be demonstrated that the system is self-purging.

A low-level coolant sensor shall be provided and shall be accessible by an exterior access door at ground level. The sensor shall display both at the filler location as well as on the dash. The water filler

shall be no more than 60 inches above the ground and both shall be accessible through the same access door.

The radiator, shall be of durable corrosion-resistant construction. Plastic tanks are not permitted. All radiators shall be designed so a 2M mechanic can gain access to a substantial portion for the purpose of cleaning the radiators in five minutes or less.

Radiators with a fin density greater than 12 fins per inch, and louvered/slit designs, are more susceptible to clogging and deteriorating cooling performance over time and shall not be used.

All hose clamps shall be constant tension type clamps.

The radiators shall be designed to withstand thermal fatigue and vibration associated with the installed configuration.

TS 22.1.1 Thermal Management Specifications

Electric fans shall be brushless, variable speed, reversible and have a corrosion resistant metal shroud with finger guards that meet SAE spec J1308 200808. The fans should provide electronic feedback control and have diagnostics capability through the standard SAE J1939 diagnostics port. The cooling system shall consist of multiple electric DC brushless pusher type variable speed fans with electronic feedback controls. Electric fan motor speeds shall have a minimum operating range of 0-5,500 rpm with capability of manual or automatic reverse operation in order to assist in debris removal. The Fan Reverse setting shall be capable of being manually activated by a technician and shall be programmable to automatically reverse as specified by the City in the pre-production meeting. The manual Fan Reverse switch shall be located as specified by the City during the pre-production meeting. The cooling system shall be equipped with a master controller with the following capabilities:

- Automatically reduce fan speed when the vehicle stops to minimize noise at the curbside
- Communicate on the J1939 CAN data link with system diagnostic retorting via dm1 messaging
- Review and download data via a laptop with service tool software
- Capable of software and calibration up-dates
- Receive commands from the
- Report fault codes by lighting an propulsion system compartment led flashing light
- Sense propulsion system compartment temperature and activate fans if maximum temperature is exceeded
- Collect and store cooling system and vehicle performance histogram data

Service tool software must include history, data and logging analysis tool. If system controller loses communication with the propulsion system or sensors it shall direct all fans to go into a default speed mode to avoid vehicle shutdown. If fans lose communication with system controller, they shall go into a default speed mode to avoid vehicle shutdown.

Curbside quit mode must rely on two vehicle speed sources, the vehicle speed and propulsion system speed. Telematics must be able to query cooling system for performance, malfunction data, and reverse fans. An external site glass shall be installed in the cooling system for easy visual inspection of fluid level of cooling system. A coolant level sensor shall be installed in the surge tank. Electrical connections shall match the propulsion system and vehicle's existing wiring harness installed. The sensor shall be compatible with the Electric Vehicle System Controller (EVSC). This communication between the cooling system module and the diagnostic tool shall use the industry standard RP1210 compliant datalink adapters connected via the standard 9-pin diagnostic connector found in the engine compartment and interior of the bus. Independent diagnostic detection shall be capable of identifying specifically which fan, measured input parameter, or datalink input parameter is experiencing a fault condition. Report both active and previously active fault codes with the number of detections/occurrences, time of the first and most recent fault detection, and cumulative time the fault was active. Where electric fans are used for cooling there shall be ample field experience. As a

minimum, 500 electric fan based cooling systems shall be in transit revenue generating operation for at least 4 years.

TS 22.1.2 Surge Tank

A stainless steel surge tank with a sight glass to determine satisfactory propulsion system coolant level shall be mounted above the radiator and shall be accessible by opening one of the propulsion system compartment's access doors. The surge tank shall include a manual pressure relief valve, an automatic cooling system pressure control system, a low coolant sensor and provisions for adequate de-aeration of the cooling system. A spring-loaded, push-button type pressure relief valve shall be provided, to safely release pressure or vacuum in the cooling system. The coolant filler and pressure release valve shall be no more than sixty-six (66) inches above the ground and shall be accessible through the same access door.

The cooling system shall have a coolant recovery system consisting of a coolant recovery reservoir and overflow hose. The recovery reservoir shall provide an air space in the cooling system that allows the coolant to expand and contract. Coolant shall be allowed to flow back and forth between the radiator and the reservoir when the pressure in the cooling system gets too high. The pressure valve in the pressure cap shall allow the coolant, which has expanded due to being heated, to flow through the overflow hose and into the recovery reservoir. As the propulsion system cools down and a vacuum is created it shall open the vacuum valve in the pressure cap, allowing some of the coolant in the reservoir to be siphoned back into the radiator. Under normal operating conditions, no coolant shall be lost. As the coolant circulates, any air that is present in the cooling system will accumulate at the pressure cap as this shall be the highest point. When the pressure cap releases it is the air which is expelled first. When the system goes into vacuum it shall draw the coolant back into the cooling system.

TS 22.1.3 Coolant Tubing/Hoses/Clamps

All tubing shall be made of 16 gauge aluminized or stainless steel. The tubing shall be mandrel bent (to assure smooth bends) to match the propulsion system and cooling system connection points, with the minimum amount of hose connections. Welded tubing will be allowed only if the radius cannot be achieved with mandrel bending. The tubing shall be properly supported to prevent damage from propulsion system vibration, movement, chafing, or abrasion. Each tube end shall be free of burrs and sharp edges, and machine beaded to insure proper clamping to hose. Lines passing through the frame or bulkhead shall be protected by grommets, or similar devices, that fit snugly to both the line and the perimeter of the hole that the line passes through to prevent chafing and wear.

All hoses over 1 inch diameter shall be 4 ply Teflon stainless steel braided Aeroquip type or City reviewed equal that are impervious to all bus fluids, 1 inch diameter and smaller shall be at least 2 ply Teflon stainless steel braided Aeroquip type or City reviewed equal that are impervious to all bus fluids. Silicone type hose may be used where Teflon stainless steel braided hoses are not applicable, i.e. radiator and heater hoses. EPDM rubber hose is not acceptable in the cooling system. Hoses over 1 inch diameter may not be over 8 inches in length overall; tubing as per above specifications shall be used instead. Fittings shall be made of brass, bronze, or stainless steel. Black iron pipe or PVC is not acceptable.

Clamps shall be 100 percent premium stainless steel constant torque clamps that provide a complete 360° seal, with smooth interior bands so as not to damage the silicone hose. Clamps for hose over 1 inch diameter shall be T-bolt type. Clamps for hose 1 inch diameter or less may be worm screw type, with smooth interior bands. The clamps shall maintain a constant tension at all times, expanding and contracting with the hose in response to temperature changes and aging of the hose material.

Radiator tubes shall be of the welded type with minimum wall thickness of .006 inch. Lock seams shall not be used. Necessary hoses shall be a premium 5 ply silicone rubber type that is impervious to all bus fluids. All hoses shall be secured with 100% premium stainless steel constant torque clamps that provide a complete 360° seal, with smooth interior bands so as not to damage the silicone hose. The

clamps shall maintain a constant tension at all times, expanding and contracting with the hose in response to temperature changes and aging of the hose material.

Piping, tubing, and hoses shall be routed away from heat sources, and shielded as required to meet the temperature rise requirements of the propulsion system manufacturers.

TS 22.2 Energy Storage System (ESS) Thermal Management

Comply _____ Do Not Comply _____

The Energy Storage System (ESS) shall be supported by a full thermal management system to keep the batteries at optimal operational temperature to assure performance and long life. The ESS thermal management system shall be independent and separate from the traction motor cooling system.

When heat is required, heat should be pulled from the cabin heating system and applied to the batteries. The cabin coolant fluid network shall interface via heat exchanger with the ESS coolant loop. Both coolant loops shall share the same reservoir.

When batteries require cooling, a dedicated rooftop 24 volt electric condenser unit shall be engaged to release excess heat. The condenser shall be paired with a compressor running a refrigerant cycle with R407.

TS 22.3 Transmission Cooling

Comply _____ Do Not Comply _____

The transmission shall be cooled by a dedicated heat exchanger sized to maintain operating fluid within the transmission manufacturer's recommended parameters of flow, pressure and temperature. The transmission cooling system must be separate from the traction motor cooling system. The transmission cooling system shall be a standalone system designed to circulate oil through a small radiator next to the transmission.

TS 22.4 Radiator

Comply _____ Do Not Comply _____

The bus shall be equipped with 2 radiators: one for power electronics and propulsion system; and the other for battery cooling. Both radiators shall be designed to withstand thermal fatigue and vibration associated with the installed configuration. The radiator cores shall be easily cleaned with standard pressure-washing equipment.

The radiator shall be of sufficient size to maintain all propulsion system fluids and ESS at safe, continuous operating temperatures during the most severe operations possible. The unit shall maintain operating temperatures in accordance with propulsion system components and ESS manufacturers' cooling system requirements in the following conditions:

- The outside ambient temperature is at 130° degrees Fahrenheit and
- The coach is operating with the equivalent weight on board equal to a full seated load, plus 3,725 pounds for standees and
- On a six (6) percent grade and;
- With the air conditioning running at maximum output

TS 22.4.1 Radiator Piping

Radiator piping shall be stainless steel, brass tubing, or powder coated steel; and, if practicable, hoses shall be eliminated. EPDM coolant hoses for heavy vehicle applications SAEJ20R3 specs, and silicone in limited areas as required.

All hoses shall be as short as practicable. All hoses shall be secured with constant tension spring clamps made from high tensile spring steel (51CrV4) and treated for 1000 hour ASTM B-117 corrosion resistance. I. The clamps shall maintain a constant tension at all times, expanding and contracting with the hose in response to temperature changes and aging of the hose material.

TS 22.4.2 Radiator Fins

Radiator fins shall be copper flat dimpled design, and shall be soldered to the tubes. Radiators with a fin density greater than 12 fins per inch, and louvered/slit designs, are more susceptible to clogging and deteriorating cooling performance over time and therefore shall not be used.

TS 22.4.3 Radiator Screen

The radiator input shall be protected by an easily cleanable screen designed to collect large debris.

TS 22.4.4 Mounting

The lower edge of the radiator core(s) shall be mounted at a height not less than 3 ft. above street level to minimize core fouling caused by dirt, debris, leaves, etc. The radiator may be roof mounted.

TS 22.5 Coolant

Comply _____ Do Not Comply _____

An all-season coolant shall be furnished to provide protection down to minus 20 degrees Fahrenheit and up 130 degrees Fahrenheit. Nalcool corrosion inhibitor and coolant stabilizer shall be added to the cooling system in quantities recommended by the propulsion system manufacturers.

TS 22.5.1 Cooling System Filter

The cooling system shall be equipped with a properly sized water filter with a spin-on element and an automatic system for releasing supplemental coolant additives as needed to replenish and maintain protection properties. When replacing the water filter, only the water in the filter will be lost.

TS 22.6 Drive Design

Comply _____ Do Not Comply _____

The bus shall be equipped with an EMP electric fan drive cooling system. A screen guard must be installed on electric motor fans per SAE J1308.

TS 23. Oil & Hydraulic Systems

Comply _____ Do Not Comply _____

The hydraulic system(s) shall demonstrate a mean time between repairs in excess of 50,000 miles. Hydraulic system service tasks shall be minimized and scheduled no more frequently than those of other major coach systems. All elements of the hydraulic system shall be easily accessible for service or unit replacement. Critical monitoring points in the hydraulic system shall be fitted with service ports so that portable diagnostic equipment may be connected or sensors for an off-board diagnostic system permanently attached to monitor system operation when applicable. A tamper-proof priority system shall prevent the loss of power steering during operation of the bus if other devices are also powered by the hydraulic system. The hydraulic system shall operate within the allowable temperature range as specified by the lubricant manufacturer. Sensors in the hydraulic system, excluding those in the power steering system, shall indicate on the operator's on-board diagnostic panel conditions of low hydraulic fluid level.

The hydraulic power steering pump shall be electrically driven and located in the front of the vehicle in the same compartment as the steering gear and a dedicated power steering hydraulic reservoir.

If the wheelchair ramp is hydraulically actuated, it must be powered by a hydraulic system independent of the power system hydraulic system. Thus, the wheelchair ramp hydraulic system should possess its own dedicated electrically driven hydraulic pump, reservoir and controller.

TS 23.1 Lines

Comply _____ Do Not Comply _____

All pressurized circuits, to the extent practical, shall be made of properly secured rigid stainless steel pipes and tubing except in locations where flexible lines are required. All "transition" connections between rigid and non-rigid members of the bus shall be made using high pressure hydraulic hoses. All flexible hydraulic lines in propulsion system compartment are to be stainless steel braided Teflon lined hoses rated for the application. Acceptable hose manufacturers are Parker or City reviewed equal.

Hydraulic lines of the same size and with the same fittings as those on other piping systems of the bus, but not interchangeable, are tagged or marked for use on the hydraulic system only. All hoses, pipes, lines and fittings shall be specified and installed per the manufacturer's recommendations.

Lines and pipes shall be capable of withstanding maximum system pressures. Lines and pipes shall be compatible with the substances they carry and designed for use in the environment where they are installed (for example, high pressure, high-temperature resistant, resistant to road salts near the road surface, and so on).

TS 23.2 Routing and Securement

Comply _____ Do Not Comply _____

Lines and piping shall be as short as practicable. Lines should be sufficiently flexible to minimize mechanical loads on the components. All lines and piping shall be routed and rigidly supported to prevent chafing damage, fatigue failures, degradation and tension strain. Lines should be sufficiently flexible to minimize mechanical loads on the components. If lines have unavoidable points of contact against frame members or other components, sleeve protectors shall be provided. Lines and piping passing through a panel, frame or bulkhead shall be protected by grommets (or similar devices) that fit snugly to both the line and the perimeter of the hole that the line/pipe passes through to prevent chafing and wear. Pipes and fluid hoses shall not be bundled with or used to support electrical wire harnesses.

Lines shall be shielded with clamped snap-tite, hose guard, HGU-Polyurethane sleeves or City reviewed equal, so that failure of a line shall not allow the contents to spray or drain onto any component operable above the auto-ignition temperature of the fluid. Sleeves shall be permanently clamped and secured on one end. This requirement (Snap-Tite sleeves) applies to the low pressure and high flow circuits (return lines) in the hydraulic system.

All fluid lines/pipes/hoses shall be secured, within a maximum of 15 inch centers, using cushioned clamp tube support or bolted plastic clamp supports subject to the City's approval. Lines and pipes shall not be bundled with or used to support electrical wire harnesses.

Hydraulic lines of the same size and with the same fittings as those on other piping systems of the bus, but not interchangeable, shall be tagged or marked for use on the hydraulic system only.

TS 23.3 Clamps

Comply _____ Do Not Comply _____

All hoses, pipes, and flexible lines shall be secured by means of using Swagelok, or City reviewed equal cushion clamp (split-block) tube support, or bolted plastic clamp supports, subject to City's review. All clamps shall maintain a constant tension at all times, expanding and contracting with the line in response to temperature changes and aging of the hose/pipe/line material. The lines shall be designed for use in the environment where they are installed (for example, high-temperature resistant in the rear battery compartment, resistant to road salts near the road surface, and so on).

TS 23.4 Fittings

Comply _____ Do Not Comply _____

Connections shall be heavy duty, with 500 F degrees minimum operating range. All pressurized hydraulic lines/hoses, throughout the bus shall be equipped with permanent, machine crimped steel JIC flare type fittings. Reusable fittings are not acceptable. Fittings shall be Parker Seal-Lok, O-Ring Face Seal Fittings, or City reviewed equal. Compression fittings shall be standardized to prevent the

intermixing of components. Compression fitting components from more than one manufacturer shall not be mixed, even if the components are known to be interchangeable. All fitting attachments to castings, housings and hydraulic components shall be SAE straight thread with O-ring seal rather than tapered pipe thread.

TS 24. Structure

TS 24.1 General Design

Comply _____ Do Not Comply _____

The bus shall have a clean, smooth, simple design, primarily derived from bus performance requirements and passenger service criteria established by these Technical Specifications.

The exterior and body features, including grilles and louvers, shall be shaped to facilitate cleaning by automatic bus washers without snagging washer brushes. Water and dirt shall not be retained in or on any body feature to freeze or bleed out onto the bus after leaving the washer. The body, doors and windows shall be sealed to prevent leaking of air, dust, or water under normal operating conditions and during cleaning in automatic bus washers for the service life of the bus.

The structure of the bus shall be designed to withstand the transit service conditions typical of an urban or intercity duty cycle throughout its service life. The vehicle structural frame shall be designed to operate with minimal maintenance throughout the 12 year design operating profile. The design operating profile specified by the City shall be considered for this purpose.

The contractor shall supply the City with a Failure Element Analysis (FEA) to indicate the structure has been designed so that fatigue damage will not occur during the service life of the vehicle. The basic structure shall withstand fatigue damage that is sufficient to cause Class 1 or Class 2 failure. The structure shall also withstand impact and inertial loads due to street travel throughout the coach's service life without permanent deformation or damage.

Exterior panels shall be sufficiently stiff to minimize vibration, drumming or flexing while the bus is in service. When panels are lapped, the upper and forward panels shall act as a watershed. However if entry of moisture into interior of bus is prevented by other means, then rear cap panels may be lapped otherwise. The windows, hatches, and doors shall be able to be sealed. Accumulation on any window of the bus of spray and splash generated by the bus's wheels on a wet road shall be minimized. The basic bus structure shall be designed so that fatigue damage will not occur throughout the service life of the vehicle.

TS 24.2 Fleet Failures

Comply _____ Do Not Comply _____

The vehicle structural frame and design shall be designed to operate with minimal maintenance and to withstand the normal conditions of transit service throughout the twelve (12) year service life of the vehicle. The design operating profile specified by the City shall be considered for this purpose.

The design shall incorporate all severe service and heavy-duty features available from the manufacturer. Any manufacturer whose bus has been involved in a structurally related fleet failure (failures in excess of 10 percent) at any transit property in the United States in the last five years must have completed a detailed investigation of the failure and a detailed structural analysis, including any necessary finite element analysis of the complete structure to eliminate any effect on any part of the structure. All failures involving basic body structure, axles, and suspension are considered structurally related failures for the purposes of these specifications. Any investigations of failure and any structural analysis must be completed by a reputable, independent transit industry consultant and shall not be limited to finite element modeling but shall be confirmed by actual track testing with suitable time concentration to prove the capability of the modified structure to perform for 600,000 miles.

The Contract shall analyze and determine the cause of all failures and record them in a database. More than five percent (5%) failure during the warranty period will require corrective action with

supporting tests and analysis. Failures over twenty percent (20%) during the warranty period will be considered a fleet defect and require a fleet-wide detailed failure analysis, corrective action, and fleet-wide parts replacement. The Contractor shall assume all costs (Labor, Parts, Freight, any Travel Expenses, Round trip Towing, Shipping, and etc.) associated with the failures, analysis, and corrective actions of the fleet failures.

TS 24.3 Altoona Testing

Comply _____ Do Not Comply _____

Prior to acceptance of first bus, the vehicle shall have undergone appropriate and completed structural testing and/or analysis, including Federal Transit Administration (FTA) required Altoona testing, to ensure adequacy of design for the urban transit service. Any items that required repeated repairs or replacement must undergo the corrective action with supporting test and analysis. A report clearly describing and explaining the failures and corrective actions taken to ensure that any and all such failures will not occur shall be submitted to the City. The Altoona Test Report shall be provided to the Agency with the Bid submittal.

TS 24.3.1 Altoona Test Report

The Contractor shall provide the City with a completed report of Altoona testing for the proposed bus model, along with a plan of corrective action to address deficiencies, breakdowns and other issues identified during Altoona testing. The bus model tested shall match the bus model proposed for procurement, including structure, axles and drivetrain. Base model and partial Altoona test reports are acceptable when the combination of these tests adequately represents the proposed bus model.

Bidders are required to submit with the bid a final Altoona Bus Test Report or Documentation from the FTA identifying the vehicle(s) offered as compliant with existing Altoona testing.

Any items that required repeated repairs or replacement must undergo the corrective action with supporting test and analysis. A report clearly describing and explaining the failures and corrective actions taken to ensure any and all such failures will not reoccur shall be submitted to the City.

TS 24.4 Structural Validation

Comply _____ Do Not Comply _____

The structure of the proposed bus model shall have undergone structural testing and or analysis prior to assembly of the first bus. The Contractor shall provide the City with completed reports of Altoona testing or Finite Element Analysis (FEA) and any other structural tests performed by the Contractor or as specified by the City.

TS 25. Water Leak Test

Comply _____ Do Not Comply _____

The roof, windows, windshields, and all doors of all buses shall be water tested for a minimum of 30 continuous minutes in order that leaks may be detected and corrected. The water test should replicate a sustained driving rain. Water spray nozzles shall be located to provide an overlapping pattern to effectively test the full length of the roof, sides, front and back of the bus at a flow rate of 2.5 gallons per minute per nozzle. All defects discovered during the tests shall be logged at least on the same document which records each water leak test. Each repair associated with the results of a water leak test shall be followed by a 15 continuous minute water leak test.

TS 26. Distortion

Comply _____ Do Not Comply _____

The bus, loaded to GVWR and under static conditions, shall not exhibit deflection or deformation that impairs the operation of the steering mechanism, doors, windows, passenger escape mechanisms or

service doors. Static conditions shall include the vehicle at rest with any one wheel or dual set of wheels on a 6 in. curb or in a 6 in. deep hole.

TS 27. Frame (If Applicable)

Comply _____ Do Not Comply _____

The frame construction shall utilize a material quality no less than high-tensile steel (SAEJ410 Grade 950 D) for structural strength. The structure shall feature full-length longitudinal members throughout, with cross-members, pillar, roof bows and bulkheads. The total girder-type structure shall be designed for maximum strength, reliability and durability. All joints shall be welded per AWA standards. Welds shall be free of all defects including, but not limited to porosity, holes and cold welds. All nuts, bolts, and washers shall be stainless steel to prevent corrosion. All structural nuts and bolts shall be SAE Grade 8 quality or better. All clips and clamps shall be stainless steel with a neoprene coating. Under conditions of transit service throughout the service life of the bus, the basic structure shall withstand fatigue damage that is sufficient to cause Class 1 or Class 2 failure. The structure shall also withstand impact and inertial loads due to street travel throughout the bus's service life without permanent deformation or damage. The bus, at GVWR and under static conditions, shall not exhibit deformation or deflection that impairs the operation of doors, windows, or other mechanical elements. Static conditions include the bus at rest with any one wheel or dual set of wheels on a 6-inch curb or a 6-inch deep hole.

TS 28. Resonance and Vibration

Comply _____ Do Not Comply _____

All structure, body and panel-bending mode frequencies, including vertical, lateral and torsional modes, shall be sufficiently removed from all primary excitation frequencies to minimize audible, visible or sensible resonant vibrations during normal service.

TS 28.1 Propulsion System Compartment Bulkheads

Comply _____ Do Not Comply _____

The passenger and propulsion system compartment shall be separated by fire-resistant bulkheads. This bulkhead shall preclude or retard propagation of an propulsion system compartment fire into the passenger compartment and shall be in accordance with the Recommended Fire Safety Practices defined in FTA Docket 90A, dated October 20, 1993. Only necessary openings shall be allowed in the bulkhead, and these shall be fire-resistant. Any passageways for the climate control system air shall be separated from the propulsion system compartment by fire-resistant material. Piping through the bulkhead shall have fire-resistant fittings sealed at the bulkhead. Wiring may pass through the bulkhead only if connectors or other means are provided to prevent or retard fire propagation through the bulkhead. Propulsion system access panels in the bulkhead shall be fabricated of fire-resistant material and secured with fire-resistant fasteners. These panels, their fasteners and the bulkhead shall be constructed and reinforced to minimize warping of the panels during a fire that will compromise the integrity of the bulkhead.

TS 28.2 Crashworthiness

Comply _____ Do Not Comply _____

The bus body and roof structure shall withstand a static load equal to 150 percent of the curb weight evenly distributed on the roof with no more than a 6 in. reduction in any interior dimension. Windows shall remain in place and shall not open under such a load. These requirements must be met without the roof-mounted equipment installed.

The bus shall withstand a 25 mph impact by a 4,000 lb. automobile at any point, excluding doorways, along either side of the bus and the articulated joint, if applicable, with no more than 3 in. of permanent structural deformation at seated passenger hip height. This impact shall not result in sharp edges or protrusions in the bus interior.

Exterior panels below 35 in. from ground level shall withstand a static load of 2,000 lbs. applied perpendicular to the bus by a pad no larger than 5 sq. inches. This load shall not result in deformation that prevents installation of new exterior panels to restore the original appearance of the bus.

TS 29. Corrosion

Comply _____ Do Not Comply _____

The bus flooring, sides, interior walls, panels, enclosures, roof, understructure and axle suspension components shall be designed to resist corrosion or deterioration from atmospheric conditions and de-icing materials for a period of 12 years or 500,000 miles, whichever comes first. It shall maintain structural integrity and maintain original appearance throughout its service life. The Contractor shall not require the complete reapplication of corrosion compounds over the life of the bus.

The bus shall be constructed using only inherently corrosion-resistant materials such as, stainless steel, non-metallic composites and fasteners to minimize deterioration. All materials that are not inherently corrosion resistant shall be protected with corrosion-resistant coatings, such as corrosion protected fill in tubing and undercoating. All joints and connections of dissimilar metals shall be corrosion resistant and shall be protected from galvanic corrosion. Representative samples of all materials and connections shall withstand a two-week (336-hour) salt spray test in accordance with ASTM Procedure B-117 with no structural detrimental effects to normally visible surfaces and no weight loss of over 1 percent. The bus manufacturer shall provide certification, in writing, that all materials and connections are in compliance with this procedure.

In the event that the bus body is made from corrosion resistant composite materials, it shall not need any undercoating spray. All exposed metal surfaces under the bus shall be both E-coated and powder coated. The entire body shall be manufactured to Docket 90 standards.

All framing and welded surfaces shall be treated with a cleaning solution and coated with any of the following: Red Oxide Primer, PPG DPV 166 High Solids Chromate Primer, Epoxy Zinc Chromate Primer, Black Zinc, Red Oxide Zinc, or bus manufacture's formulation as reviewed by the City. All electrical components, fuel tank(s), engine / transmission assembly, pipe and tube fittings, air lines and brake system components, shall be protected from undercoating spray.

All exposed surfaces and the interior surfaces of tubing and other enclosed members shall be corrosion resistant through application of a corrosion protection system.

TS 30. Towing

Comply _____ Do Not Comply _____

Towing devices shall be provided on each end of the bus. Towing devices should accommodate flat-bedding or flat-towing. Each towing device shall withstand, without permanent deformation, tension loads up to 1.2 times the curb weight of the bus within 20 deg. of the longitudinal axis of the bus. The rear towing device(s) shall not provide a toehold for unauthorized riders. The method of attaching the towing device shall not require the removal, or disconnection, of front suspension or steering components. Removal of the bike rack is permitted for attachment of towing devices.

The rear towing device(s) shall permit lifting and towing of the bus for a short distance, such as in cases of an emergency, to allow access to provisions for front towing of the bus. Each towing device shall accommodate a crane hook with a 1-inch throat.

Shop air connectors shall be provided at the front and rear of the bus and shall be capable of supplying all pneumatic systems of the bus with externally sourced compressed air. The location of these shop air connectors shall facilitate towing operations.

A plug connector permanently mounted at the front of the bus shall provide for bus tail light, marker, stop and turn signal light operation as controlled from the towing vehicle. The connector shall include a spring-loaded dust- and water-resistant cap.

Glad-hand type connectors shall be provided at the front of the bus to allow the towing vehicle to control and operate the bus braking system during a towing operation.

The front towing devices shall allow attachment of adapters for a rigid tow bar and shall permit the lifting and towing of the bus, at curb weight, while the front wheels are clear off the ground. These devices shall also permit common flat towing. The method of attaching the tow bar shall require the specific, in writing, approval of the City prior to delivery of the buses.

Two rear recovery devices/tie downs shall permit lifting and towing of the bus for a short distance, such as in cases of an emergency, to allow access to provisions for front towing of bus. The method of attaching the tow bar or adapter shall require the specific approval of the City. Any tow bar or adapter exceeding 50 lbs. should have means to maneuver or allow for ease of use and application. Each towing device shall accommodate a crane hook with a 1 in. throat.

Upon delivery of the first bus the manufacturer shall provide two (2) tow adapters.

TS 31. Jacking

Comply _____ Do Not Comply _____

It shall be possible to safely jack up the bus, at curb weight, with a common 10-ton floor jack with or without special adapter, when a tire or dual set is completely flat and the bus is on a level, hard surface, without crawling under any portion of the bus. Jacking from a single point shall permit raising the bus sufficiently high to remove and reinstall a wheel and tire assembly. Jacking pads located on the axle or suspension near the wheels shall permit easy and safe jacking with the flat tire or dual set on a 6 in. high run-up block not wider than a single tire. The bus shall withstand such jacking at any one or any combination of wheel locations without permanent deformation or damage.

Jacking and changing any one tire shall be completed by a specialist mechanic in less than 30 minutes from the time the bus is approached. Jacking pads shall be painted safety yellow for ease of identification.

TS 32. Jack Stand Interface

Comply _____ Do Not Comply _____

The bus shall be equipped with pads suitable for placement of stationary jack stands. These pads shall be permanently located to the buses main structure and capable of providing a stable platform when used in combination with "standard" jack stands. Further requirements of pads and standard interface, as follows:

- Pads shall be located as near the vehicles perimeter as practical, ahead of the front axle and rearward of the rear axle.
- Pads shall be located to facilitate un-obstructed removal of the front axle, rear axle, differential carrier assembly, and propulsion system.
- Pads shall interface to a standard jack stand having a 5 inch square platform with a center indexing pin of 1 inch diameter x 1 inch in height.

TS 33. Hoisting

Comply _____ Do Not Comply _____

The bus axles or jacking plates shall accommodate the lifting pads of a two-post (or three-post if 60 ft. articulated bus) hoist system. Jacking plates, if used as hoisting pads, shall be 5 sq. in. with a turned-down flange not more than 1 in. deep on each side and designed to prevent the bus from falling off the hoist. Other pads or the bus structure shall support the bus on jack stands independent of the hoist.

The vehicle shall be capable of lifting by the wheels, and, as necessary to meet tire load requirements, the proper number for wheel lifts and/or adapters must be used.

TS 34. Floor
TS 34.1 Design

Comply _____ Do Not Comply _____

The floor shall be essentially a continuous plane, except at the wheel housings and platforms. The floor height shall be designed to eliminate steps and facilitate boarding and de-boarding of passengers. The floor design shall consist of two levels (bi-level construction). Aft of the rear door extending to the rear settee riser, the floor height may be raised to a height approximately 18 inches above the lower level. An increase slope shall be allowed on the upper level not to exceed 3-1/2 deg. off the horizontal.

Where the floor meets the walls of the bus, as well as other vertical surfaces such as platform risers, the surface edges shall be blended with a circular section of radius not less than 1/4 in. or installed in a fully sealed butt joint. Similarly, a molding or cover shall prevent debris accumulation between the floor and wheel housings. The vehicle floor in the area of the entrance and exit doors shall have a lateral slope not exceeding 2 deg. to allow for drainage.

The floor shall be constructed of exterior waterproof plywood (marine grade), a minimum of 3/4 in. thick 7 ply. Resin waterproof bond laminate fir, or City reviewed equal. The floor shall be supported, fastened and sealed to maintain its integrity throughout the life of the vehicle. The floor covering should be Altro Transflor floor covering – meta/pewter grey TFW2789 2.7mm, for aisle and under seats. or City reviewed equal, and be installed without gaps or openings between mating joints. The entrance area and standee areas are to be separated by a yellow strip molded into the flooring. The operator's area shall be covered with smooth flooring. The City is interested in alternatives to the traditional plywood floor and manufacturers sharing this interest are encouraged to submit composite alternatives during the City reviewed equals period. Manufactures are encouraged to provide alternative flooring materials that do not corrode.

TS 34.2 Strength

Comply _____ Do Not Comply _____

The floor deck may be integral with the basic structure or mounted on the structure securely to prevent chafing or horizontal movement and designed to last the life of the bus. Sheet metal screws shall not be used to retain the floor, and all floor fasteners shall be serviceable from one side only. Any adhesives, bolts or screws used to secure the floor to the structure shall last and remain effective throughout the life of the coach. Tapping plates, if used for the floor fasteners, shall be no less than the same thickness as a standard nut, and all floor fasteners shall be secured and protected from corrosion for the service life of the bus.

The floor deck shall be reinforced as needed to support passenger loads. At GVWR, the floor shall have an elastic deflection of no more than 0.60 in. from the normal plane. The floor shall withstand the application of 2.5 times gross load weight without permanent detrimental deformation. The floor, with coverings applied, shall withstand a static load of at least 150 lbs. applied through the flat end of a 1/2 in. diameter rod, with 1/32 in. radius, without permanent visible deformation.

TS 34.3 Construction

Comply _____ Do Not Comply _____

The floor shall consist of the subfloor and the floor covering that will last the life of the bus. The floor as assembled, including the sealer, attachments and covering, shall be waterproof, non-hygroscopic and resistant to mold growth. The subfloor shall be resistant to the effects of moisture, including decay (dry rot). It shall be impervious to wood-destroying insects such as termites.

If plywood, before any preservative treating, the plywood shall be certified at the time of manufacturing by an industry-approved third-party inspection such as APA – The Engineered Wood Association (formerly the American Plywood Association). Plywood shall be of a thickness adequate to support design loads, manufactured with exterior glue, satisfy the requirements of a Group I Western panel as defined in PS 1-95 (Voluntary Product Standard PS 1-95, "Construction and Industrial Plywood") and

be of a grade that is manufactured with a solid face and back. Plywood shall be installed with the highest-grade, veneer side up and with all edges sealed. Plywood shall be pressure-treated with a preservative chemical process such as alkaline copper quaternary (ACQ) that prevents decay and damage by insects.

Preservative treatments shall utilize no EPA-listed hazardous chemicals. The concentration of preservative chemicals shall be equal to or greater than required for an above ground level application. Treated plywood will be certified for preservative penetration and retention by a third-party inspection agency. Pressure-preservative treated plywood shall have a moisture content at or below 15 percent. A barrier shall be installed to prevent contact by road salt with the plywood panels.

TS 35. Platforms

TS 35.1 Operator's Area

Comply _____ Do Not Comply _____

Platform height shall not exceed 15 inches. Trim shall be provided along top edges of platforms unless integral nosing is provided. Except where otherwise indicated, covering of platform surfaces and risers shall be same material as specified for floor covering. Trim installed along edges of platforms shall be constructed of stainless steel. Other raised areas such as for providing space for under-floor installation of components shall be limited. Such raised areas shall be constructed in accordance to these specifications. Specific trim required to be specified by the City.

TS 35.2 Operator's Platform

Comply _____ Do Not Comply _____

The operator's platform shall be of a height such that, in a seated position, the operator can see an object located at an elevation of 42 in. above the road surface, 24 in. from the leading edge of the bumper. Notwithstanding this requirement, the platform height shall not position the operator such that the operator's vertical upward view is less than 15 deg. A warning decal or sign shall be provided to alert the operator to the change in floor level. Figure 2 illustrates a means by which the platform height can be determined, using the critical line of sight. Anti-skid material shall be used on the operator's platform. An adhesive type of antiskid material shall not be accepted. The Contractor shall apply or install a long lasting friction enhancing coating or RCA flooring and this item shall be subjected to the City's approval.

FIGURE 2
 Determining Platform Height

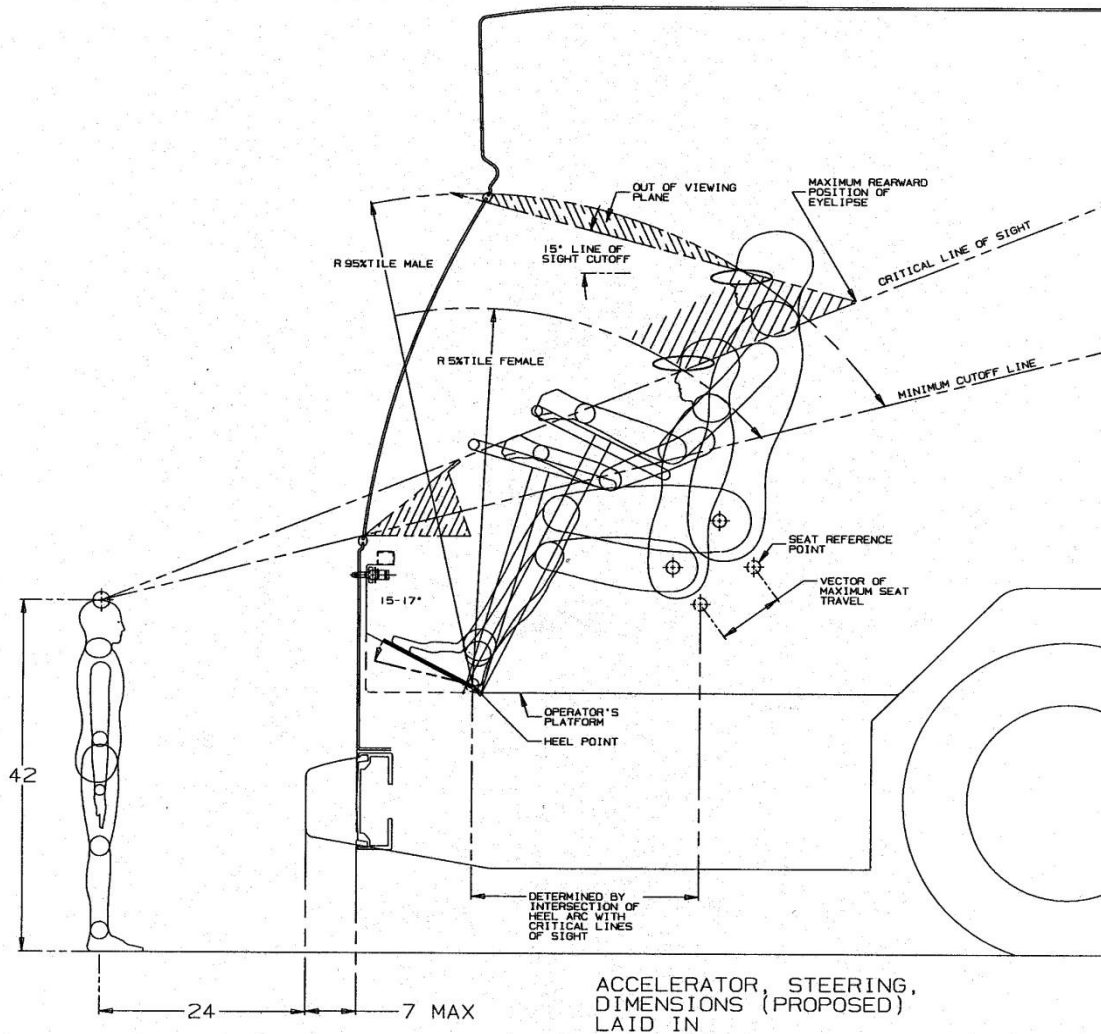

TS 35.3 Farebox

Comply _____ Do Not Comply _____

Farebox placement should minimize impact to passenger access and minimize interference with the operator's line of sight. Contractor shall prewires and build platform for farebox per SPX Genfare requirements. All wire connections shall be fuse protected, crimped, soldered and heat shrunk protected.

TS 35.4 Rear Step Area to Rear Area

Comply _____ Do Not Comply _____

If the vehicle is of a bi-level floor design, then a rear step area shall be provided along the center aisle of the bus to facilitate passenger traffic between the upper and lower floor levels. This step area shall be cut into the rear platform and shall be approximately the aisle width, a minimum 12 in. deep and approximately half the height of the upper level relative to the lower level. The horizontal surface of this platform shall be covered with skid-resistant material with a visually contrasting nosing and shall be

sloped slightly for drainage. A warning decal or sign and yellow step nosing shall be provided at the immediate platform area to alert passengers to the change in floor level.

TS 36. Suspension

TS 36.1 General Requirements

Comply _____ Do Not Comply _____

The front and rear suspensions shall be pneumatic type. The basic suspension system shall last the service life of the bus without major overhaul or replacement. Normal replacement items, such as suspension bushing, shock absorbers, or air spring shall be replaceable by a service mechanic in 45 minutes or less. Adjustment points shall be minimized and shall not be subject to a loss of adjustment in service. Routine and necessary adjustments shall be easily accomplished without removal or disconnecting the components.

TS 36.2 Alignment

Comply _____ Do Not Comply _____

All axles should be properly aligned so the vehicle tracks accurately within the size and geometry of the vehicle.

TS 36.3 Springs and Shock Absorbers

Comply _____ Do Not Comply _____

TS 36.3.1 Suspension Travel

The suspension system shall permit a minimum wheel travel of 2.75 in. bounce-upward travel of a wheel when the bus hits a bump (higher than street surface), and 2.75 in. rebound-downward travel when the bus comes off a bump and the wheels fall relative to the body. Elastomeric bumpers shall be provided at the limit of bounce travel. Rebound travel may be limited by elastomeric bumpers or hydraulically within the shock absorbers. Suspensions shall incorporate appropriate devices for automatic height control so that regardless of load the bus height relative to the centerline of the wheels does not change more than +/- 1/2 in. at any point from the height required. The safe operation of a bus cannot be impacted by ride height up to 1 in. from design normal ride height.

TS 36.3.2 Air Suspension

A full air suspension system which functions by compressed air and is regulated by leveling valves is required. The air suspension system shall consist of two (2) air bellows rear axles and two (2) air bellows for the front axle. The system shall use leveling valves to maintain constant height of body in relation to axles, regardless of load. Source of air shall be a separate tank, and a pressure regulating valve shall protect against air loss from leaks or failure of suspension system. A time delay must be incorporated in the leveling valves to prohibit excessive use of air during rapid axle fluctuations. The air system must have a safety device which will prevent the loss of air beyond safe operating limits in case of failure or leaks in any or all of the suspension systems. Coach suspension system shall consist of either rolling lobe or double convolution flexible bellows. The front suspension system shall be equipped with a "Kneeling" feature that is controlled by an operator-operated switch on the dash.

The basic suspension system shall last 500,000 miles without overhaul or replacement. Items such as bushings and air bellows shall be easily and quickly replaceable by a mechanic. Adjustment points shall be minimized and shall not be subject to a loss of adjustment in service. Necessary adjustments shall be easily accomplished without removing or disconnecting the components.

Adequate urethane-bushed radius rods shall be provided to control lateral, longitudinal, and torsional movement.

Telescope type, double-acting shock absorbers are to be provided on each side of axle at front and rear. Shock absorbers shall be Koni or City reviewed equal.

Individual manufacturer's suspension systems may vary in construction but must meet basic specification requirements.

TS 36.3.3 Damping

Vertical damping of the suspension system shall be accomplished by hydraulic shock absorbers mounted to the suspension arms or axles and attached to an appropriate location on the chassis. Damping shall be sufficient to control coach motion to two (2) cycles or less after hitting road perturbations. Shock absorbers shall maintain their effectiveness for at least 150,000 miles of the service life of the bus. Each unit shall be replaceable by a service mechanic in less than 15 minutes. The shock absorber bushing shall be made of elastomeric material that will last the life of the shock absorber. The damper shall incorporate a secondary hydraulic rebound stop.

TS 36.3.4 Lubrication

All elements of steering, suspension and drive systems requiring scheduled lubrication shall be provided with grease fittings conforming to SAE Standard J534. These fittings shall be located for ease of inspection and shall be accessible with a standard grease gun without a flexible hose end from a pit or with the bus on a hoist. Each element requiring lubrication shall have its own grease fitting with a relief path. The lubricant specified shall be standard for all elements on the bus serviced by standard fittings and shall be required no less than every 7,000 miles.

TS 36.3.5 Kneeling

A kneeling system shall lower the entire right side of the bus a minimum of 2.5 in. during loading or unloading operations regardless of load up to GVWR, measured at the longitudinal centerline of the entrance door(s) by the operator. The kneeling control shall provide the following functions:

- Downward control must be held to allow downward kneeling movement.
- Release of the control during downward movement must completely stop the lowering motion and hold the height of the bus at that position.
- Upward control actuation must allow the bus to return to normal floor height without the operator having to hold the control.

The brake and throttle interlock shall be activated and shall prevent movement when the bus is kneeled. The kneeling control shall be disabled when the bus is in motion. The bus shall kneel at a maximum rate of 1.25 in. per second at essentially a constant rate. After kneeling, the bus shall rise within 2 seconds to a height permitting the bus to resume service and shall rise to the correct operating height within 7 seconds regardless of load up to GVWR. During the lowering and raising operation, the maximum vertical acceleration shall not exceed 0.2g/sec., and the jerk shall not exceed 0.3g/sec. measured at the front door step tread.

An indicator visible to the operator shall be illuminated until the bus is raised to a height adequate for safe street travel. An audible warning alarm will sound simultaneously with the operation of the kneeler to alert passengers and bystanders. A warning light mounted near the curbside of the front door, a minimum 3 in. diameter amber lens, shall be provided that will blink when the kneel feature is activated. Kneeling shall not be operational while the wheelchair ramp is deployed or in operation.

TS 37. Wheel Housing

TS 37.1 Design and Construction

Comply _____ Do Not Comply _____

Sufficient clearance and air circulation shall be provided around the tires, wheels and brakes to preclude overheating when the bus is operating on the design operating profile. Wheel housings shall be constructed of corrosion-resistant and fire-resistant material. Interference between the tires and any portion of the bus shall not be possible in maneuvers up to the limit of tire adhesion with weights from curb weight to GVWR. Wheel housings shall be adequately reinforced where seat pedestals are

installed. Wheel housings shall have sufficient sound insulation to minimize tire and road noise and meet all requirements of Noise.

Design and construction of the street side front wheel housings shall allow for the installation of radio/electronic equipment's storage box/compartment that shall extend, continually, from the wheel well housing's top surface to the ceiling using the maximum available section/foot-print. This storage box, and trays, is subject to the City's approval. The radio/electronic equipment compartment shall be keyed using a flush mounted 1/4" turn square key access.

The exterior finish of the front wheel housings shall be scratch-resistant, meeting requirements of Interior Panels and Finishes, and complement interior finishes of the bus to minimize the visual impact of the wheel housing. If fiberglass wheel housings are provided, then they shall be color-impregnated to match interior finishes. The lower portion extending to approximately 18 inches above floor shall be equipped with additional more resistant coating or stainless steel trim.

Wheel housings not equipped with seats or equipment enclosure shall have a horizontal assist mounted on the top portion of the housing no more than 4 in. higher than the wheel well housing.

Wheel housing as installed, shall withstand impacts of a tire tread dislodging from the tire at a maximum vehicle speed without penetration. Wheel housings, as installed and trimmed, shall withstand impacts of a 2 in. steel ball with at least 200 ft.-lbs. of energy without penetration.

TS 38. Wheels and Tires

TS 38.1 Wheels

Comply _____ Do Not Comply _____

Wheels and rims shall be hub-piloted with 2-sided brushed aluminum Dura-Flange Alcoa, or City reviewed equal and shall resist rim flange wear. All wheels shall be interchangeable and shall be removable without a puller. Wheels shall be compatible with tires in size and load-carrying capacity. Front wheels and tires shall be balanced as an assembly per SAE J1986. Front, rear, and spare wheel/tire assemblies shall be alike.

TS 38.2 Tires

Comply _____ Do Not Comply _____

Tires shall be suitable for the conditions of transit service and sustained operation at the maximum speed capability of the bus. Load on any tire at GVWR shall not exceed the tire supplier's rating. The tires shall be of the radial type, capable of sustained speeds of 65 MPH.

Sufficient space shall be provided to allow the City to carry a spare tire, if required. The tires shall be provided under a lease agreement between the City and the tire supplier and shall be the appropriate size and load range for the vehicle.

TS 39. Steering

TS 39.1 Steering General

Comply _____ Do Not Comply _____

Hydraulically assisted power steering shall be provided. Hydraulic assisted steering shall be provided to reduce steering effort. The steering gear shall be an integral type with the number and length of flexible lines minimized or eliminated. Electrically-driven hydraulic pump shall be provided for power steering with a six (6) GPM capacity. The steering column shall be tilt (fore and aft) and telescopic with positive mechanical lock on both adjustments with steel/ metal outer housing.

The steering geometry of the outside (front lock) wheel shall be within 2 deg. of true Ackerman up to 50 percent lock measured at the inside (back lock) wheel. The steering geometry shall be within 3 deg. of true Ackerman for the remaining 100 percent lock measured at the inside (back lock) wheel.

Gearing shall require no more than seven turns of the steering wheel lock-to-lock.

TS 39.2 Turning Effort

Comply _____ Do Not Comply _____

Steering effort shall be measured with the bus at GVWR, stopped with the brakes released on clean, dry, level, commercial asphalt pavement and the tires inflated to recommended pressure.

Under these conditions, the torque required to turn the steering wheel 10 deg. shall be no less than 5ft.-lbs. and no more than 10 ft.-lbs. Steering torque may increase to 70 ft.-lbs. when the wheels are approaching the steering stops, as the relief valve activates.

Power steering failure shall not result in loss of steering control. With the bus in operation, the steering effort shall not exceed 55 lbs. at the steering wheel rim, and perceived free play in the steering system shall not materially increase as a result of power assist failure. Gearing shall require no more than seven turns of the steering wheel lock-to-lock. Caster angle shall be selected to provide a tendency for the return of the front wheels to the straight position with minimal assistance from the operator.

TS 39.3 Steering Wheel and Horn – General

Comply _____ Do Not Comply _____

The steering wheel diameter shall be approximately 18 to 20 in.; the rim diameter shall be .875 to 1.25 in. and shaped for firm grip with comfort for long periods of time. The steering wheel shall be removable with a standard or universal puller.

Steering wheel spokes and wheel thickness shall ensure visibility of the dashboard so that vital instrumentation is clearly visible at center neutral position (within the range of a 95th-percentile range as described in SAE 1050a, Sections 4.2.2 and 4.2.3). Placement of steering column must be as far forward as possible, but either in line with or behind the instrument cluster.

A horn button shall be located in the steering wheel hub and shall be protected from debris accumulation and shall not incorporate any manufacturer logo. Dual electric horns shall be mounted to prevent water and dirt into horn trumpets. The horns shall sound high and low notes (notes D & F) that are clearly audible over 80 dBA traffic noises at a distance of 300 feet.

TS 39.4 Steering Column Tilt/Telescope

Comply _____ Do Not Comply _____

The steering column shall be tilt (fore and aft) and telescopic with positive mechanical lock on both adjustments with steel/metal outer housing.

TS 39.4.1 Steering Column Tilt Adjustment

The steering column shall have full tilt capability with a rearward tilt adjustment range of no less than 45 deg. as measured from the horizontal and upright position and easily be adjustable by the operator and shall be accessible by a 5th percentile female and 95th percentile male.

TS 39.4.2 Steering Wheel Telescopic Adjustment

Measurement – From the top of the rim of the steering wheel in the horizontal position to the cab floor at the heel point. The steering wheel shall have full telescoping capability and have a maximum telescopic range of 3 in. and a minimum low-end adjustment of 29 in., measured from the top of the steering wheel rim in the horizontal position to the cab floor at the heel point.

Table 3 acknowledged as the standard for measurements of thigh clearance, resting elbow height, the slope of the steering wheel, and the height of the wheel, and the relationship of one to another, to assist in determining the appropriate telescopic range.

TABLE 3

Steering Wheel Height¹ Relative to Angle of Slope

(Based on Drillis and Contini, 1966)

		Thigh Clearance	Resting Elbow Height
5 Percentile Female		19.1"	22.1"
95 Percentile Male		25.6"	30.4"
Steering Wheel Height (Measured from Bottom Portion Closest to Operator) Relative to Angle of Slope			
At Minimum Telescopic Height Adjustment (29")		At Maximum Telescopic Height Adjustment (35")	
Angle of Slope	Height	Angle of Slope	Height
0 degrees	29"	0 degrees	35"
15 degrees	26.2"	15 degrees	31.2"
25 degrees	24.6"	25 degrees	29.6"
35 degrees	22.5"	35 degrees	27.5"

- 1. Measured from bottom portion closest to driver.

TS 40. Turning Radius

Comply _____ Do Not Comply _____

Turning Radius shall be per Table 4 and Figure 3 below.

TABLE 4

Maximum Turning Radius

Bus Length (approximate)	Maximum Turning Radius (see Figure 3)
40 ft.	41 ft. (TR0)

FIGURE 3

Turning Radius

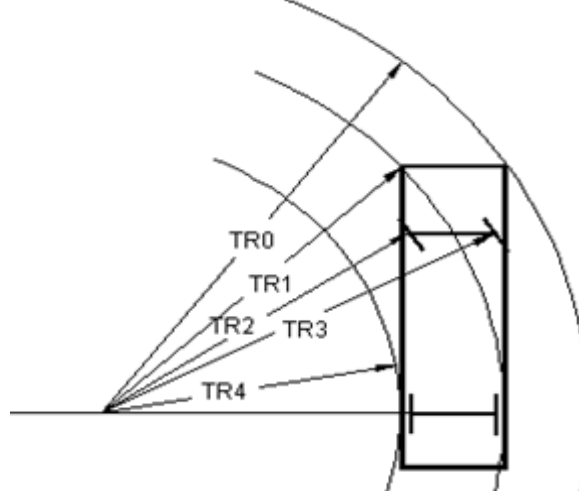

TS 41. Front (Steering) Axle

Comply _____ Do Not Comply _____

The front axle shall be of a solid beam or Independent suspension design, non-driving with a load rating sufficient for the bus loaded to GVWR and shall be equipped with sealed, oiled-type front wheel bearings. Axle hubs shall provide for stud mounting of wheels.

All friction points on the front axle shall be equipped with replaceable bushings or inserts and lubrication fittings easily accessible from a pit or hoist.

TS 42. Drive Axle And Drive Shaft

Comply _____ Do Not Comply _____

The bus shall be driven by a heavy-duty axle with a load rating sufficient for the bus loaded to GVWR. Transfer of gear noise to the bus interior shall be minimized. The drive axle shall have a design life to operate for not less than 500,000 miles on the design operating profile without replacement or major repairs. The lubricant drain plug shall be magnetic type. If a planetary gear design is employed, the oil level in the planetary gears shall be easily checked through the plug or sight gauge.

The drive shaft components shall be heavy duty. Universal joints and drive shaft slip joints will have separate grease fittings accessible by a standard grease gun. The drive shaft shall be guarded to prevent hitting any critical systems, including brake lines, coach floor or the ground, in the event of a tube or universal joint failure.

The axle and driveshaft components shall be rated for both propulsion and retardation modes with respect to duty cycle.

TS 43. Hubs

Comply _____ Do Not Comply _____

Replaceable wheel bearing seals shall run on replaceable wear surfaces or be of an integral wear surface sealed design. All friction points on the front axle shall be equipped with replaceable bushings or inserts and lubrication fittings easily accessible from a pit or hoist. Wheel bearing and hub seals and unitized hub assemblies shall not leak or weep lubricant for 100,000 miles when operating on the design operating profile.

TS 44. Brakes

TS 44.1 Service Brake

Comply _____ Do Not Comply _____

Service brakes shall be air actuated disc brakes on both the front and rear axles and the brake discs shall allow machining the surfaces up to ¼ inch each side to obtain smooth surfaces. The disc brake system and replacement parts shall be commercially available in North America. The entire service brake system, including friction materials, shall be designed to have an overhaul or minimum replacement life of 60,000 miles with brake retardation through regenerative braking. Brakes shall be self-adjusting and combined with both "End of Life" & "Continuous Wear" electronic brake pad indication systems. Brake wear indicators (visible brake sensors) shall be provided on exposed push rods. Visible stroke indicators may be combined with electronic brake monitoring system and vehicle brake warning system to notify operator and maintenance of unsafe brake conditions.

The brake system material and design shall be selected to absorb and dissipate heat quickly so the heat generated during braking operation does not glaze brake linings. The heat generated shall not increase the temperature of tire beads and wheel contact area to more than that allowed by the tire manufacturer.

TS 44.2 Actuation

Comply _____ Do Not Comply _____

Service brakes shall be controlled and actuated by a compressed air system with a single actuator at each wheel. Disc brakes shall have either axial or radial air actuation with a single floating caliper operation.

Force to activate the brake pedal control shall be an essentially linear function of the bus deceleration rate and shall not exceed 50 lbs. at a point 7 in. above the heel point of the pedal to achieve maximum braking. The heel point is the location of the operator's heel when his or her foot is rested flat on the pedal and the heel is touching the floor or heel pad of the pedal. The ECU for the ABS system shall be protected, yet in an accessible location to allow for ease of service.

The total braking effort shall be distributed among all wheels in such a ratio as to ensure equal friction material wear rate at all wheel locations. Manufacturer shall demonstrate compliance by providing a copy of a thermodynamic brake balance test upon request. Buses shall not be equipped with automatic traction control. The brake system material and design shall be selected to absorb and dissipate heat quickly so that the heat generated during braking operation does not glaze the brake linings.

TS 44.3 Anti-Lock Braking System

Comply _____ Do Not Comply _____

The brake system shall be equipped with all wheel anti-lock braking system (ABS) without Traction Control by Rockwell, Wabco or City reviewed equal. The Contractor shall provide complete performance data and system design of the brake system with ABS. The design shall be reviewed by the City. The ABS/EBC controller must support EBC1 (PGN 61441) "Brake Pedal Position" (SPN 521) to support and enhance fuel savings technologies. The ECU for the ABS system shall be protected, yet in an accessible location to allow for ease of service.

TS 44.4 Rotors

Comply _____ Do Not Comply _____

The bus shall be equipped with disc brakes on all axles, brake rotors shall be sized to the vehicle weight and wheel diameter and meet all FMVSS requirements. The brake rotors shall be able to be resurfaced/machining the surfaces up to ¼ inch each side of the disc in the field to obtain smooth surfaces per manufacturer's specifications. The rotors shall have the minimum thickness size stamped in the casting.

The brake system material and design shall be selected to absorb and dissipate heat quickly so the heat generated during braking operation does not glaze brake linings. The heat generated shall not increase the temperature of tire beads and wheel contact area to more than that allowed by the tire manufacturer.

TS 44.5 Friction Material

Comply _____ Do Not Comply _____

The brake linings shall be made of non-asbestos material. In order to aid maintenance personnel in determining extent of wear, a provision such as a scribe line or a chamfer indicating the thickness at which replacement becomes necessary shall be provided on each brake lining. The complete brake lining wear indicator shall be clearly visible from the hoist or pit without removing backing plates. A light on the operator's dash board shall indicate need for brake service.

TS 44.6 Parking/Emergency Brake

Comply _____ Do Not Comply _____

The parking brake shall be a spring-operated system, actuated by a valve that exhausts compressed air to apply the brakes. The parking brake may be manually enabled when the air pressure is at the operating level per FMVSS 121. An emergency brake release shall be provided to release the brakes in the event of automatic emergency brake application. The parking brake valve button will pop out when air pressure drops below requirements of FMVSS 121. The operator shall be able to manually depress

and hold down the emergency brake release valve to release the brakes and maneuver the bus to safety. Once the operator releases the emergency brake release valve, the brakes shall engage to hold the bus in place. Air to the emergency brake release system shall be provided by a dedicated emergency air tank.

TS 45. Interlocks

TS 45.1 Passenger Door Interlocks

Comply _____ Do Not Comply _____

To prevent opening front and rear passenger doors while the bus is in motion, a speed sensor shall be integrated with the door controls to prevent the doors from being enabled or opened unless the bus speed is less than 2 mph.

To preclude movement of the bus while any door is open, an accelerator interlock shall lock the accelerator in the closed position, and a brake interlock shall engage the service brake system to stop movement of the bus when the operator's door control is moved to any door enable or open position, or any door panel is opened more than 3 in. from the fully closed position (as measured at the leading edge of the door panel). The interlock system shall also energize the emergency four-way flasher system. The interlock engagement shall bring the bus to a smooth stop and shall be capable of holding a fully loaded bus on a 6 percent grade, until the interlocks are released. When the interlock system has been activated, it will not release until a light application and release of the brake pedal is made. These interlock functions shall be active whenever the vehicle Master Run Switch is in any run position.

All door systems employing brake and accelerator interlocks shall be supplied with supporting failure mode effects analysis (FEMA) documentation, which demonstrates that failure modes are of a failsafe type, thereby never allowing the possibility of release of interlock while an interlocked door is in an unsecured condition, unless the door master switch has been actuated to intentionally release the interlocks.

The brake interlock regulator shall be non-adjustable. Braking effort shall be adjustable with hand tools.

TS 45.2 Accelerator Interlock

Comply _____ Do Not Comply _____

To preclude movement of the bus, an accelerator interlock shall lock the accelerator in the closed position, and a brake interlock shall engage the service brake system when the front and rear door control is activated. The brake interlock regulator shall be non-adjustable. Braking effort shall be adjustable with hand tools.

TS 46. Pneumatic System

TS 46.1 General

Comply _____ Do Not Comply _____

The bus air system shall operate the air-powered accessories and the braking system with reserve capacity. New buses shall not leak down more than 5 psi over a 15-minute period of time from the point of governor cut-off as indicated on the instrument panel mounted dash gauge.

Provision shall be made to apply shop air to the bus air systems using a standard shop air hose quick connect coupler, ¼ in. x ¼ in. NPT Male Steel Automotive Standard Plug Air Line Nipple Type "C". A quick disconnect fitting shall be easily accessible and located in the propulsion system compartment and near the front bumper area for towing. Retained caps shall be installed to protect fitting against dirt and moisture when not in use. Air for the compressor shall be filtered. The air system shall be protected per FMVSS 121, by a pressure relief valve set at 150 psi and shall be equipped with check valve, pressure protection valves and positive hand shut-off valves to assure partial operation in case of line failures. All air tank drains shall be identified with labels and made easily accessible.

TS 46.2 Air Compressor

Comply _____ Do Not Comply _____

The electrically-driven air compressor shall be City approved and sized to charge the air system from 40 psi to the governor cutoff pressure in less than 3. A piston type air compressor is not acceptable. Air compressor shall have constant positive intake pressure or be unloaded through the air dryer system. The compressor output rattling shall be dependent of the manufacturer's calculations of the required volumes necessary for normal transit operation including but not limited to braking, door operation, air suspension and all other components requiring pneumatic power. The calculation shall be presented and explained to the City for approval during prototype review.

TS 46.3 Air Lines and Fittings

Comply _____ Do Not Comply _____

Air lines, except necessary flexible lines, shall conform to the installation and material requirements of SAE Standard J1149 for copper tubing with standard, brass, flared or ball sleeve fittings, or SAE Standard J844 for nylon tubing if not subject to temperatures over 200° F. The air on the delivery side of the compressor where it enters nylon housing shall not be above the maximum limits as stated in SAE J844. Nylon tubing shall be installed in accordance with the following color-coding standards:

- **Green:** Indicates primary brakes and supply.
- **Red:** Indicates secondary brakes.
- **Brown:** Indicates parking brake.
- **Yellow:** Indicates compressor governor signal.
- **Black:** Indicates accessories.

Line supports shall prevent movement, flexing, tension, strain and vibration. Copper lines shall be supported to prevent the lines from touching one another or any component of the bus. To the extent practicable and before installation, the lines shall be pre-bent on a fixture that prevents tube flattening or excessive local strain. Copper lines shall be bent only once at any point, including pre-bending and installation. Rigid lines shall be supported at no more than 5ft. intervals. Nylon lines may be grouped and shall be supported at 2 ft. intervals or less.

The compressor discharge line between power plant and body-mounted equipment shall be flexible Teflon hose with a braided stainless steel jacket. Other lines necessary to maintain system reliability shall be flexible Teflon hose with a braided stainless steel jacket. End fittings shall be standard SAE or JIC brass or steel, flanged, swivel-type fittings. Flexible hoses shall be as short as practicable and individually supported at 2 ft. intervals or less. They shall not touch one another or any part of the bus except for the supporting grommets.

Air lines shall be clean before installation and shall be installed to minimize air leaks. All air lines shall be sloped towards a reservoir and routed to prevent water traps. Grommets or insulated clamps shall protect the air lines at all points where they pass through understructure components.

TS 46.4 Air Reservoirs

Comply _____ Do Not Comply _____

All air reservoirs shall meet the requirements of FMVSS Standard 121 and SAE Standard J10 and shall be equipped with clean-out plugs, manual and automatic drain plugs, and guarded or flush type drain valves. Major structural members shall protect these valves and any automatic moisture ejector valves from road hazards. Reservoirs shall be sloped toward the drain valve. All air reservoirs shall have drain valves that discharge below floor level with lines routed to eliminate the possibility of water traps and/or freezing in the drain line. Automatic drain valves shall be Haldex or City reviewed equal. All tank drains shall be permanently labeled.

TS 46.5 Air System Dryer

Comply _____ Do Not Comply _____

A provision shall be included to collect/remove oil from the air system to prevent affecting function and/or damaging pneumatic system components. The air dryer system shall prevent accumulation of moisture and oil in the air system. The dryer shall be located before the no. 1 air tank and as far from the compressor as possible to allow air to cool prior to entering the air dryer.

The air dryer system shall include a replaceable desiccant bed, electrically heated drain, and activation device. A mechanic shall replace the desiccant in less than 15 minutes. The dryer will be a Bendix AD9 or City reviewed equal. A Bendix, part # 801731, Puraguard QC oil coalescent filter, or City reviewed equal, shall be installed following the manufacturer's specifications for location, height and ease of draining.

TS 47. Operator's Area

TS 47.1 General

Comply _____ Do Not Comply _____

The operator's work area shall be designed to minimize glare to the extent possible. Objects within and adjacent to this area shall be matte black or dark gray in color wherever possible to reduce the reflection of light onto the windshield. The use of polished metal and light-colored surfaces within and adjacent to the operator's area shall be avoided. Such objects include dash panels, switches and controls, cowlings, windshield wipers and arms, barriers and modesty panels, fare stanchions, access panels and doors, fasteners, flooring, ventilation and heating ducting, window and door frames, and visors. Interior lighting located ahead of the standee line shall be controlled by the operator. In general, when designing the operator's area, SAE Recommended Practice, J833, Human Physical Dimensions, shall be used.

All switches and controls necessary for the safe operation of the bus shall be conveniently located in the operator's area and shall provide for ease of operation. Switches and controls shall be divided into basic groups and assigned to specific areas, in conformance with SAE Recommended Practice J680, Revised 1988, "Location and Operation of Instruments and Controls in Motor Truck Cabs," and be essentially within the hand reach envelope described in SAE Recommended Practice J287, "Driver Hand Control Reach".

TS 47.2 Glare

Comply _____ Do Not Comply _____

The operator's work area shall be designed to minimize glare to the extent possible. Objects within and adjacent to this area shall be matte black or dark gray in color wherever possible to reduce the reflection of light onto the windshield. The use of polished metal and light-colored surfaces within and adjacent to the operator's area shall be avoided. Such objects include dash panels, switches and controls, cowlings, windshield wipers and arms, barriers and modesty panels, fare stanchions, access panels and doors, fasteners, flooring, ventilation and heating ducting, window and door frames, and visors.

TS 47.3 Visors/Sun Shades

Comply _____ Do Not Comply _____

An adjustable roller type sunscreen shall be provided over the operator's windshield and the operator's side window and shall be designed so that there is no gap between the windshield and operator's side window visors. The sunscreen shall be capable of being lowered to the midpoint of the operator's window. When deployed, the screen shall be secure, stable, and shall not rattle, sway or intrude into the operator's field of view due to the motion of the coach or as a result of air movement. Sunscreen shall store out of the way and shall not obstruct airflow from the climate control system or interfere with other equipment, such as the radio handset or the destination control. Deployment of the visors shall not restrict vision of the rearview mirrors. The sunscreen adjustments shall be made easily by hand and construction and materials shall be strong enough to resist breakage during adjustments. Once lowered, the screen shall remain in the lowered position until returned to the stowed position by the

operator. Sunscreen shall be shaped to minimize light leakage between the visor and windshield pillars to the extent possible.

Roller blind shall be mounted to maximize the operators' protection from heat and solar glare. Screen shall not be mounted in any way that diminishes the operators' ability to operate the coach safely. Screens shall not have any strings or loose attachment hardware. Screens shall be of constant tension design to minimum rattle. The screen design shall allow infinite adjustment of the screen length.

TS 47.4 Operator's Controls

Comply _____ Do Not Comply _____

All switches and controls necessary for the safe operation of the bus shall be conveniently located in the operator's area and shall provide for ease of operation. Switches and controls shall be divided into basic groups and assigned to specific areas, in conformance with SAE Recommended Practice J680, Revised 1988, Location and Operation of Instruments and Controls in Motor Truck Cabs, and be essentially within the hand reach envelope described in SAE Recommended Practice, J287, "Driver Hand Control Reach".

All panel-mounted switches and controls shall be marked with easily read identifiers. Text designating position (on/off) shall be a minimum of 9 points, identifying legends shall be a minimum of 11 points. Extremely condensed or italic type fonts shall not be used. Graphical symbols shall conform to SAE Recommended Practice J2402, Road Vehicles – symbols For Controls, Indicators, and Tell Tales, where available and applicable. Color of switches and controls shall be dark with contrasting typography or symbols. Red type on a black or gray field (or vice versa) shall not be used.

All indicators shall have a method of momentarily testing operation. Wherever possible, sensors shall be of the closed circuit type so that failure of the circuit or sensor or both shall activate the malfunction indicator. Audible alarms shall be loud enough for the operator to hear and to be inclined to discontinue operation of the bus.

Frequently used controls must be in easily accessible locations. These include the door control, kneel control, windshield wiper/washer controls, ramp, and lift and run switch. Any switches and controls necessary for the safe operation of the bus shall be conveniently located and shall provide for ease of operation. They shall be identifiable by shape, touch and permanent markings. Controls shall also be located so that passengers may not easily tamper with control settings. Doors shall be operated by a single control, conveniently located and operable in a horizontal plane by the operator's left hand. The setting of this control shall be easily determined by position and touch. The operator should not be required to stand or turn his/her body to view or to actuate these controls unless specified otherwise.

Critical systems or components monitored by onboard diagnostics system shall be displayed in clear view of the operator. This display shall have visual and/or audible indicators. The intensity of indicators shall permit easy determination of on/off status in bright sunlight, but shall not cause a distraction or visibility problem at night. All indicators shall be illuminated using back lighting.

Space shall be provided on the panel for future additions of no less than five spare indicators as the capability of onboard diagnostic systems improves. Blank spaces shall contain LED's.

Mechanical switches and controls shall be replaceable, and the wiring at these controls shall be serviceable from a convenient location. Switches, controls and instruments shall be dust- and water-resistant.

All switches/controls and transmission shift selector in the operator's controls area shall be mounted in an angled panel steep enough to discourage operators from using it as a personal storage area for items such as cell phones, music players, navigation systems, etc.

The layouts and locations of the switches, controls, indicators, interment panels, and operator panels shall be reviewed by the City prior to the production of each bus order.

TS 47.5 Normal Bus Operation Instrumentation and Controls

Comply _____ Do Not Comply _____

The following list identifies bus controls used to operate the bus. These controls are either frequently used or critical to the operation of the bus. They shall be located within easy reach of the operator and shall be approved prior to the manufacturing of the buses. The contractor shall submit to the City the layout and configuration of all dash and control panel indicators and gauge locations for approval. The operator shall not be required to stand or turn to view or actuate these controls unless specified otherwise.

Systems or components monitored by onboard diagnostics system shall be displayed in clear view of the operator and provide visual and/or audible indicators. The intensity of indicators shall permit easy determination of on/off status in bright sunlight but shall not cause a distraction or visibility problem at night. All indicators shall be illuminated using backlighting.

The indicator panel shall be located in Area 1 or Area 5, within easy view of the operator instrument panel. All indicators shall have a method of momentarily testing their operation. The audible alarm shall be tamper-resistant and shall have an outlet level between 80 and 83 dBA when measured at the location of the operator's ear.

On-board displays visible to the operator shall be limited to indicating the status of those functions described herein that are necessary for the operation of the bus. All other indicators needed for diagnostics and their related interface hardware shall be concealed and protected from unauthorized access. Table 5 represents instruments and alarms. The intent of the overall physical layout of the indicators shall be in a logical grouping of systems and severity nature of the fault.

Consideration shall be provided for future additions of spare indicators as the capability of onboard diagnostic systems improves. Blank spaces shall contain LEDs.

TABLE 5
 Transit Bus Instruments and Alarms

Device	Description	Location	Function	Visual/ Audible
Master run switch	Rotary, four-position detent	Side console	Master control for bus, off, day run, night run and clearance ID lights	
Bus start, front	Approved momentary switch	Side console	Activates engine starter motor	
Drive selector	Touch panel switch	Side console	Provides selection of propulsion: forward, reverse and neutral	Gear selection
HVAC	Switch or switches to control HVAC	Side console	Permits selection of passenger ventilation: off, cool, heat, low fan, high fan or full auto with on/off only	
Operator's ventilation	Rotary, three-position detent	Side console or dash left wing	Permits supplemental ventilation: fan off, low or high	
Defroster fan	Rotary, three-position detent	Side console or dash left wing	Permits defroster: fan off, low, medium or high	
Defroster temperature	Variable position	Side console or dash left wing	Adjusts defroster water flow and temperature	
Windshield wiper	One-variable rotary position operating both wipers	Dash left wing	Variable speed control of left and right windshield wipers	
Windshield washer	Push button	Dash left wing	Activates windshield washers	

TABLE 5
 Transit Bus Instruments and Alarms

Device	Description	Location	Function	Visual/ Audible
Dash panel lights	Rotary rheostat or stepping switch	Side console or dash left wing	Provides adjustment for light intensity in night run position	
Interior lights	Three-position switch	Side console	Selects mode of passenger compartment lighting: off, on, normal	
Front door ramp enable	Two-position keyed switch	Dash right wing	Permits ramp and kneel activation from front door area	Amber light
Front door ramp	Three-position momentary switch	Dash right wing	Permits deploy and stow of front ramp	Amber light; exterior alarm
Front kneel	Three-position momentary switch	Dash right wing	Permits kneeling activation and raise and normal at front door remote location	Amber dash indicator; exterior alarm
Silent alarm	Recessed push button, NO and NC contacts momentary	Side console	Activates emergency radio alarm at dispatch and permits covert microphone and/or enables destination sign emergency message	
Video system event switch	Momentary on/off momentary switch with plastic guard	Side console	Triggers event equipment, triggers event light on dash	Amber light
Passenger door control	Five-position handle type detent or two momentary push buttons	Side console, forward	Permits open/close control of front and rear passenger doors	Red light on push button indicating door open, amber light in instrument cluster indicating door open
Rear door override	Two-position switch in approved location	Side console, forward	Allows operator to override activation of rear door passenger tape switches	
Automatic shutdown override	Momentary switch with operation protection	Side console	Permits operator to override auto engine shutdown	Continuous buzzer
Hazard flashers	Two-position switch	Side console or dash right wing	Activates emergency flashers	Two green left/right indicator lights
Fire suppression	Red push button with protective cover	Dash left wing or dash center	Permits operator to override and manually discharge fire suppression system	Red light
Mobile data terminal	Mobile data terminal coach operator interface panel	Above right dash wing	Facilitates operator interaction with communication system and master log-on	LCD display with visual status and text messages
Farebox interface	Farebox coach operator interface panel	Near farebox	Facilitates operator interaction with farebox system	LCD display
Destination sign interface	Destination sign interface panel	In approved location	Facilitates operator interaction with destination sign system, manual entry	LCD display
Turn signals	Momentary push button (two required) raised from other switches	Left foot panel	Activates left and right turn signals	Two green lights and optional audible indicator
PA manual	Momentary push button	Left foot panel	Permits operator to manually activate public address microphone	

TABLE 5
 Transit Bus Instruments and Alarms

Device	Description	Location	Function	Visual/ Audible
Low-profile microphone	Low-profile discrete mounting	In approved location	Permits operator to make announcements with both hands on the wheel and focusing on road conditions	
High beam	Detented push button	Left foot panel	Permits operator to toggle between low and high beam	Blue light
Parking brake	Pneumatic PPV	Side console or dash left wing	Permits operator to apply and release parking brake	Red light
Master door/interlock	Multi-pole toggle, detented	Out of operator's reach	Permits operator override to disable door and brake/throttle interlock	Red light and continuous buzzer
Warning interlocks deactivated	Red indicator light	Dash panel center	Illuminates to warn operator that interlocks have been deactivated	Red light and continuous buzzer
Alarm acknowledge	Push button momentary	Approved location	Permits operator to acknowledge alarm condition	
Rear door passenger sensor disable	Multi-pole toggle, detented	In sign compartment or operator's barrier compartment	Permits operator to override rear door passenger sensing system	
Indicator/ alarm test button	Momentary switch or programming ¹	Dash center panel	Permits operator to activate test of sentry, indicators and audible alarms	All visuals and audibles
Auxiliary power	110 V power receptacle	Approved location	Property to specify what function to supply	
Stop request acknowledge	Push button momentary	Dash left wing	Permits driver to acknowledge stop requested condition	
Speedometer	Speedometer, odometer, and diagnostic capability, 5-mile increments	Dash center panel	Visual indication of speed and distance traveled, accumulated vehicle mileage, fault condition display	Visual
Air pressure gauge	Primary and secondary, 5 psi increments	Dash center panel	Visual indication of primary and secondary air systems	Visual
Fire detection	Coach operator display	Property specific or dash center	Indication of fire detection activation by zone/location	Buzzer and red light
Door obstruction	Sensing of door obstruction	Dash center	Indication of rear door sensitive edge activation	Red light and buzzer
Door ajar	Door not properly closed	Property specific or dash center	Indication of rear door not properly closed	Buzzer or alarm and red light
Low system air pressure	Sensing low primary and secondary air tank pressure	Dash center	Indication of low air system pressure	Buzzer and red light
Propulsion system coolant indicator	Low coolant indicator may be supplied as audible alert and visual and/or text message	Within operator's sight	Detects low coolant condition	Amber light

TABLE 5
 Transit Bus Instruments and Alarms

Device	Description	Location	Function	Visual/ Audible
Hot coolant indicator	Coolant temperature indicator may be supplied as audible alert and visual and/or text message	Within operator's sight	Detects hot propulsion system condition and initiates time delay shutdown	Red light
Low oil pressure indicator	Oil pressure indicator may be supplied as audible alert and visual and/or text message	Within operator's sight	Detects low propulsion system oil pressure condition and initiates time-delayed shutdown	Red light
ABS indicator	Detects system status	Dash center	Displays system failure	Amber light
HVAC indicator	Detects system status	Dash center	Displays system failure	Amber or red light
Charging system indicator (12/24 V)	Detect charging system status	Dash center	Detects no charge condition and optionally detects battery high, low, imbalance, no charge condition, and initiates time-delayed shutdown	Red light flashing or solid based on condition
Bike rack deployed indicator	Detects bike rack position	Dash center	Indication of bike rack not being in fully stowed position	Amber or red light
Hot Coach	Red indicator	Indicator in IP Dash LCD	The Hot Coach message will appear if the Electric Drive system Detects a failure in the insulation of the high voltage system.	
High Voltage battery system state of charge	Analog gauge and digital display	Dash center	Indication of high voltage battery system state of charge	Analog dial and digital bar
Active charge/regeneration and power draw	Analog gauge and digital display	Dash center	Indication of electric regeneration, charging and power draw	Analog dial and digital bar

TS 47.6 Foot Controls

Comply _____ Do Not Comply _____

TS 47.6.1 Brake and Accelerator Pedals

Accelerator and brake pedals shall be designed for ankle motion. Foot surfaces of the pedals shall be faced with wear-resistant, nonskid, replaceable material.

TS 47.6.2 Pedal Angle

The vertical angle of the accelerator and brake pedals shall be determined from a horizontal plane regardless of the slope of the cab floor. The accelerator pedals shall be positioned at an angle of 27-37 deg. at the point of initiation of contact and extend downward to an angle of 10 to 20 deg. at full throttle. The brake pedal shall be positioned at an angle of 27–37 degrees at the point of initiation of contact, and extend downward to an angle of 5–15 degrees at full depression. The City shall approve the accelerator and brake pedal angle, actuation and recovery force as well as location.

TS 47.6.3 Pedal Dimensions

The floor-mounted accelerator and brake pedal shall be 10 to 12 in. long and 3 to 4 in. wide. Clearance around the pedal must allow for no interference precluding operation.

TS 47.6.4 Pedal Position

The accelerator and brake pedals shall be positioned such that the spacing between them, measured at the heel of the pedals, is between 1 and 2 inches. Both pedals should be located approximately on the same plane coincident to the surface of the pedals. The City shall approve the relative position between accelerator and brake pedals.

TS 47.6.5 Pedal Adjustment

Both pedals shall be adjustable forward and rearward a minimum of 3 inches. The adjustment shall be made by use of a dash-mounted toggle or rocker switch. The switch shall be clearly labeled to identify it as pedal adjustment and shall be within easy reach of the operator. Pedal adjustment shall be enabled only when the bus is stationary and the parking brake engaged.

TS 47.6.6 Pedal Force

The force to depress the accelerator and brake pedal shall be measured at the midpoint of the pedal. The accelerator force shall be no less than 7 foot pounds and no more than 9 foot pounds. The brake pedal force shall be no less than 10 foot pounds and no more than 50 foot pounds.

TS 47.6.7 Foot Switches/Turn Signal Platform

All Control Switches shall be per City reviewed locations. The control switches for the directional signals shall be mounted on an inclined, floor-mounted stainless steel enclosure or metal plate mounted to an incline integrated into the operator's platform, located to the left of the steering column. The turn signal platform shall be angled at a minimum of 10 deg. and a maximum of 21 deg. The angle of the turn signal platform shall be determined from a horizontal plane, regardless of the slope of the cab floor. The location and design of the enclosure shall be such that foot room for the operator is not impeded. It shall be located no closer to the seat front than the heel point of the accelerator and brake pedal. The inclined mounting surface shall be skid-resistant. The spacing of the switches shall be such that inadvertent simultaneous deflection of switches is prevented.

The foot switches shall be UL-listed, heavy-duty type, of a rugged, corrosion-resistant metal construction. The foot switches for the directionals shall be momentary type, while those for the PA system and the high beam shall be latching type. The hazard flashers and silent alarm may be floor mounted, momentary or latching, as identified by the City.

All turn signal lights, when available, shall be LED with a lifetime warranty.

TS 48. Operator's Amenities

TS 48.1 Coat Hanger

Comply _____ Do Not Comply _____

A suitable hanger shall be installed in a convenient, approved location for the operator's coat.

TS 48.2 Drink Holder

Comply _____ Do Not Comply _____

A device shall be provided to securely hold the operator's drink container, which may vary widely in diameter. It must be mounted in a location approved by the City. When the container is in the device, the driver's view of the road must not be obstructed, and leakage from the container must be contained as not to fall on any switches, gauges or controls.

TS 48.3 Storage Box

Comply _____ Do Not Comply _____

An enclosed operator storage area shall be provided with a positive latching door and/or lock. The minimum size is 2750 in.

TS 49. Operator's Seat

Comply _____ Do Not Comply _____

FIGURE 4
Operator's Seat

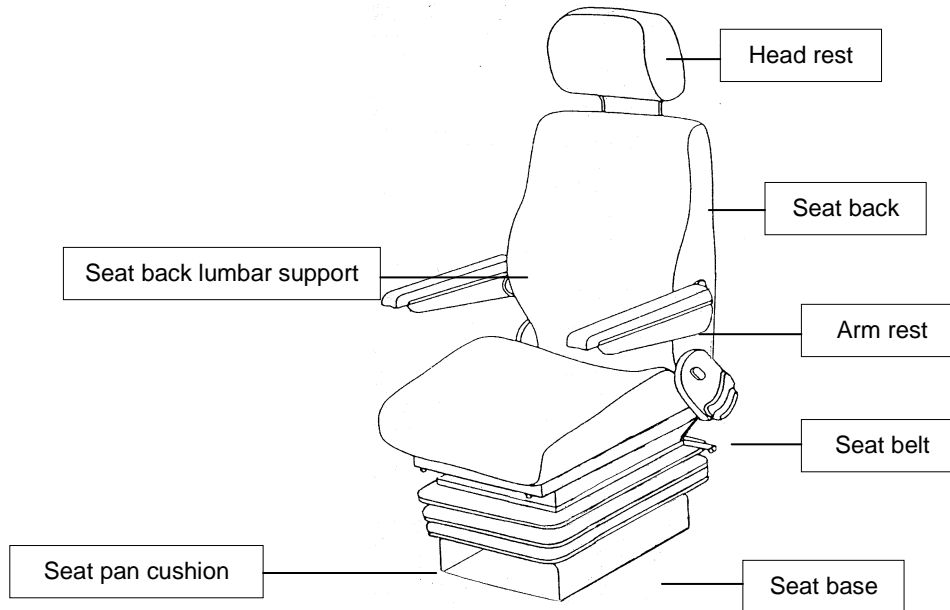

TS 49.1 General

Comply _____ Do Not Comply _____

The operator's seat shall be comfortable and adjustable so that persons ranging in size from the 95th-percentile male to the 5th-percentile female may operate the bus. While seated, the operator shall be able to make seat adjustments by hand without complexity, excessive effort, or being pinched. Adjustment mechanisms shall hold the adjustments and shall not be subject to inadvertent changes. Graphical symbols shall conform to SAE Recommended Practice (Proposed) J1458, Universal Symbols for Seat and Suspension Adjustments. Spec development. USSC 9100ALX3 is currently the City's standard operator's seat, other manufacturers and models with equal or greater properties and/or durability may be submitted for review by the City.

TS 49.2 Seat Structure and Materials

Comply _____ Do Not Comply _____

The operator's seat shall be contoured to provide maximum comfort for extended period of time. Cushions shall be fully padded with at least 4 inches of closed-cell polyurethane foam or material with equal properties or greater durability, in the seating areas at the bottom and back. Side bottom cushion/foam shall be of a denser material to prevent premature deterioration or sagging. Upholstery shall be ventilated, transportation grade material. All visually exposed metal on the operator's seat, including the pedestal, shall be unpainted aluminum or stainless steel. All materials shall meet FTA Docket 90A and FMVSS 302 standards and requirements.

Seat shall be equipped with solid steel back that prevents break-through. The seat and seatbelt assemblies, as installed in the bus, shall withstand static horizontal forces as required in FMVSS 207 and 210. The seat shall withstand 10,000 impacts of a 40-pound sandbag dropped from a height of 12 inches without visible deterioration. The seat shall be tested in the lowest vertical position and repeated with the seat in the top vertical position. The 40-pound sandbag shall be suspended on a 36-inch pendulum and shall strike the seat back 10,000 times from distances of 6, 8, 10, and 12 inches. Seat

cushion shall withstand 100,000 randomly positioned 3 1/2-inch drops of a squirming, 150-pound, smooth-surfaced, buttocks-shape striker with only minimal wear on the seat covering.

The Contractor shall provide a certified test report fully documenting compliance with all the above defined requirements with Bid. The test report shall contain a record of all testing activities, test diagrams, testing equipment, as well as test data related to loads, deflections and permanent deformation of the seat assembly. The report shall include a statement of compliance with the requirements of this section of these Technical Specifications.

TS 49.3 Dimensions and Adjustments

Comply _____ Do Not Comply _____

TS 49.3.1 Bilateral Adjustments

All seat adjustments shall activate both sides of the seat to prevent torque and increase durability.

TS 49.3.2 Seat Pan Cushion Length

Measurement shall be from the front edge of the seat pan to the rear at its intersection with the seat back. The adjustment of the seat pan length shall be no less than 16.5 in. at its minimum length and no more than 20.5 in. at its maximum length with the use of an extension.

TS 49.3.3 Seat Pan Cushion Extension

The operator's seat shall be equipped with an extension located on the forward front edge of the pan cushion that shall tilt upward and downward allowing persons ranging in size from the 5th-percentile female and 95th-percentile male.

TS 49.3.4 Seat Pan Cushion Width

Measurement is the horizontal distance across the seat cushion. The seat pan cushion shall be 17 to 21 in. across at the front edge of the seat cushion and 20 to 23 in. across at the side bolsters.

TS 49.3.5 Seat Pan Cushion Height

Measurement shall be from the cab floor to the top of the level seat at its center midpoint. The seat shall adjust in height from a minimum of 14 in., with a minimum 6 in. vertical range of adjustment.

TS 49.3.6 Seat Pan Cushion Slope

Measurement is the slope of the plane created by connecting the two high points of the seat, one at the rear of the seat at its intersection with the seat back and the other at the front of the seat just before it waterfalls downward at the edge. The slope can be measured using an inclinometer and shall be stated in degrees of incline relative to the horizontal plane (0 deg.). The seat pan shall adjust in its slope from no less than plus 12 deg. (rearward "bucket seat" incline) to no less than minus 12 deg. (forward slope).

TS 49.3.7 Seat Tilt

Two (2) knobs shall manually operate 12 deg. of step less seat tilt, one on either side of the seat. Seat tilt knob on one side is unacceptable. Seat tilt shall operate independently of the seat height adjustment, allowing full tilt at all heights. Bilateral tilt is necessary to eliminate torque in the suspension system.

TS 49.3.8 Seat Base Fore/Aft Adjustment

Measurement is the horizontal distance from the heel point to the front edge of the seat. The minimum and maximum distances shall be measured from the front edge of the seat when it is adjusted to its minimum seat pan depth (approximately 15 in.). On all low-floor buses, the seat base shall travel horizontally a minimum of 9 inches. It shall adjust no closer to the heel point than 6 inches. On all high-

floor buses, the seat base shall travel a minimum of 9 in. and adjust no closer to the heel point than 6 inches.

TS 49.3.9 Seat Back Width and Height

Measurement is the distance between the outermost points of the front of the seat back, at or near its midpoint in height. The seat back width shall be no less than 21 in. and a standard seat back height. A solid stamped steel back must support the seat back foam. Seat back must have dual recliner gears for added support.

TS 49.3.10 Seat Back Angle Adjustment

The seat back angle shall be measured relative to a level seat pan, where 90 deg. is the upright position and 90 deg.-plus represents the amount of recline.

Recline system shall engage on both sides of the backrest. Operators shall be able to adjust the backrest recline from knobs on either side of the back. Recline shall be adjustable from 90 (upright) to 105 deg. (reclined), with infinite adjustment in between.

TS 49.3.11 Seat Suspension

The operator's seat shall be appropriately dampened to support a minimum weight of 380 lbs. The suspension shall be capable of dampening adjustment in both directions. The suspension shall be of the pneumatic pendulum to eliminates torque during suspension movement and provides six (6) inches of vertical height adjustment.

Suspension system shall be damped by an air bag system. Dampers to attach to the scissors system. Rubber bumpers shall be provided to prevent metal-to-metal contact. Seat suspension shall be covered with protective bellows that prevent dust and debris from fouling the suspension system and keep fingers and other body parts clear of the scissors system.

TS 49.4 Controls

Comply _____ Do Not Comply _____

TS 49.4.1 Seat Control Locations

The seat controls shall be located on the right side of the seat in a location that while seated, the operator shall be able to make seat adjustments by hand without complexity, excessive effort or being pinched. Adjustment mechanisms shall hold the adjustments and shall not be subject to inadvertent changes.

TS 49.4.2 Quick Dump

Air valve shall incorporate quick dump feature for easy entry and egress. Air valve will have roll pin stop, not snap ring. Air valve will be mounted on the left-hand side of the seat cushion, close to the front of the seat.

TS 49.4.3 Three-Position (3-Position) Suspension Lockout

Seat shall be provided with a three-position (3-position) suspension lockout located on the left rear side of the seat frame. The outward position allows full suspension travel; the middle position limits suspension range; the inside position locks out the suspension completely for use during maintenance and for shipping purposes.

TS 49.4.4 Air Slide Release

Seat shall be equipped with air activated fore and aft slide release, (United States Patent No. 5,613,733), air pressure shall be required to release the fore/aft slides from the locked position. Design shall ensure that seat remains locked in position should there be loss of air pressure. There shall be a manual override.

TS 49.5 Seat Back Lumbar Support

Comply _____ Do Not Comply _____

Measurement is from the bottom of the seat back at its intersection with the seat pan to the top of the lumbar cushioning. Three (3) air bladders shall be located in the lumbar region of the back frame. Independent switches located on the right front side of seat frame shall activate lumbar bags. Lumbar systems shall operate off the vehicle air pressure, without pumps or motors. The seat back shall provide adjustable-depth lumbar back support with three (3) individual operating lumbar cells within a minimum range of 7 to 11 inches.

TS 49.6 Headrests

Comply _____ Do Not Comply _____

The operator's seat shall be equipped with a 4-Way adjustable head rest and be designed so that the headrest cannot be removed.

TS 49.7 Seat Belt

Comply _____ Do Not Comply _____

The belt assembly shall be an auto-locking retractor (ALR) orange three-point seatbelt webbing belt. Seat belts shall be provided across the driver's lap and diagonally across the driver's chest. A Type I seat belt shall attach at a point that moves with the seat assembly, so that the operator may adjust the seat without resetting the seat belt. Seat belts shall be stored in automatic retractors. Seat belts shall be adjustable and extended to a length of 72 inches. Location of seat belt lock, right side of operator's seat, shall be reviewed by the City. All seatbelt assemblies shall come equipped with a warning switch device to remind operators to buckle up. The seat and seatbelt assemblies as installed in the bus shall have integrated tether straps and withstand static horizontal forces as required in FMVSS 207 and 210 – Pull Test.

TS 49.8 Armrest

Comply _____ Do Not Comply _____

The seat shall have arm rests on both the right and left hand side of the seat. The seat back mounted armrests should be fully adjustable to varying positions by a single knob adjustment. The right hand armrest must be able to swing up and back to allow the operator to exit the vehicle. Armrests must have fully padded designs and positioned to meet the 5th to 95th percentile females/males.

TS 50. Passenger Seating

Comply _____ Do Not Comply _____

Contractor must provide a full technical description of seat arrangement proposed, including dimension for knee room, spacing, side view, and any alternate layout the Contractor may wish to include for consideration. Information must include price adjustments for alternate seating plans. Seat structure, shell, frame, backs, handholds, and mounting hardware shall all be constructed of stainless steel or City reviewed equal. United States Seating Aries 4MA is currently the City's standard passenger seating, other manufacturers and models with equal or greater properties, durability, and vandal resistance may be submitted for review by the City. Final seating plan subject to approval by the City. All forward facing passenger seats without a seat directly in front of it, seat just aft of wheelchair securement area, rear door, or aisles, shall have a barriero or stanchion install to prevent passengers from falling forward during hard or abrupt stop or braking.

TS 50.1 Arrangements and Seat Style

Comply _____ Do Not Comply _____

TS 50.1.1 General

The passenger seating arrangement in the bus shall be such that seating capacity is maximized and in compliance to the following requirements. The City recognizes that ramp location, foot room, hip-to-

knee room, doorway type and width, seat construction, floor level type, seat spacing requirements, etc. ultimately affect seating capacity and layout.

Passenger seats shall be arranged in a transverse, two-position forward facing configuration, except at the wheel housings, wheelchair securement areas, and platforms where aisle-facing seats may be arranged as appropriate with due regard for passenger access and comfort. At both wheelchair securement areas shall have passenger flip seats where applicable and shall have a strut assist with the ability to lock in the up position.

Raised platforms for passenger seats shall not be allowed without the City's approval. If bus is of a sloped floor design, then raised platforms for passenger seats may be provided in the rear sloped section.

There shall be no rearward facing seats in any seat configuration, unless otherwise stated in writing by the City.

TS 50.1.2 Rear Row Seat

The last row of passenger seats shall accommodate five passengers and be evenly spaced in the area provided. The seats shall latch in the closed position and shall be hinged to fully open for easy access to the propulsion system compartment. A gas spring shall be provided to assist lifting to the fully open position. A prop rod shall be provided to hold the seat in the fully opened position. An propulsion system access door shall be provided under the last row of seats in the bus. Such removable door/cover shall be noise and thermally insulated.

TS 50.2 Aisles

Comply _____ Do Not Comply _____

The aisle between the seats shall be no less than 20 in. wide at seated passenger hip height. Seat backs shall be shaped to increase this dimension to no less than 24 in. at standing passenger hip height (32").

All Contractor shall submit a copy of their proposed seat layout consistent with these specifications showing hip-to-knee and foot room dimensions, stanchion layout and wheelchair maneuverability layout prior to bid for the City's review. The Contractors shall also indicate on this layout the Free Floor Space available to standees and include the calculation of the Free Floor Space area.

The forward most transverse seats, just aft of the wheelchair area, shall be flip-up seats. The seats shall be equipped with a grab rail on the aisle side of each forward most transverse seats. The grab rail is to provide a person sitting in the forward most aisle seat something to brace themselves with in the case of an hard or abrupt stop or braking. The grab rail shall rotate away from the aisle and rest against the underside of the flip-up seats when the seats are in the flipped-up position. The grab rail shall lock in the two positions and be securely mounted to the seat frame and/or floor. A barrier in front of the forward most transverse seats, just aft the wheelchair area, may be used in place of the grab rail if the barriers will not cause a loss in possible seats.

TS 50.3 Seating Dimensions

Comply _____ Do Not Comply _____

Seat dimensions for the various seating arrangements shall have the dimensions as follows (refer to Figure 5):

- The width, W, of the two-passenger transverse seat shall be a minimum 35 in.
- The length, L, shall be 17 in., +/- 1 in.
- The seat back height, B, shall be a minimum of 15 in.
- The seat height, H, shall be 17 in., +/- 1 inches. For the rear lounge (or settee) and longitudinal seats, and seats located above raised areas for storage of under-floor components, a cushion

height of up to 18 in., +/- 2 in., will be allowed. This shall also be allowed for limited transverse seats, but only with the expressed approval of the City.

- Foot room, F.
- The seat cushion slope, S, shall be between 5 and 11 deg.
- The seat back slope, C, shall be between 8 and 17 deg.
- Hip to knee room, K.
- The pitch, P, is shown as reference only.

FIGURE 5

Seating Dimensions and Standard Configuration

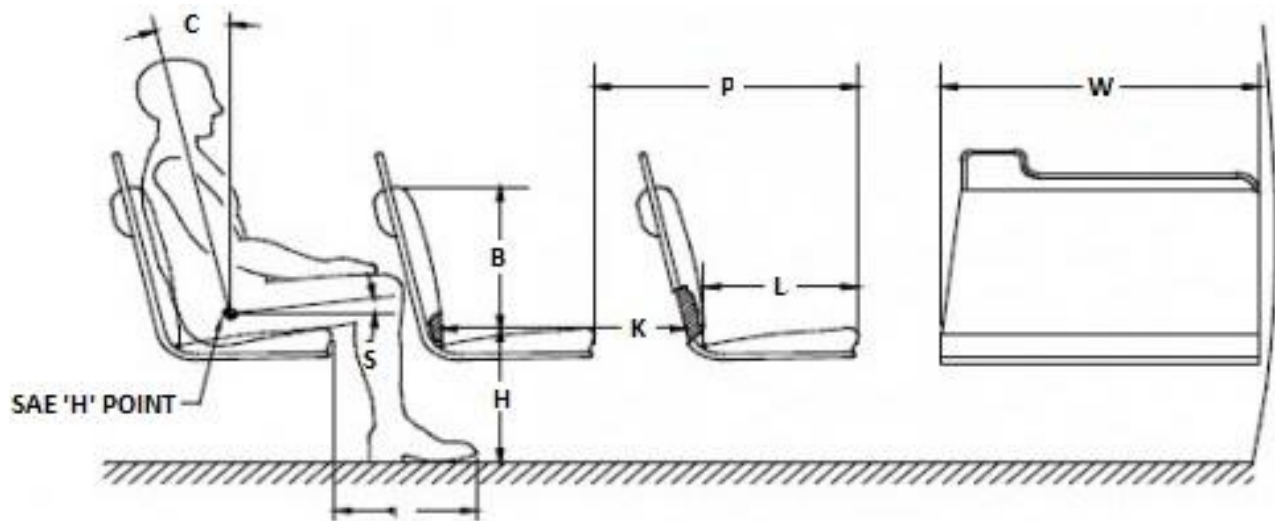

TS 50.3.1 Hip-to-Knee Room

Hip-to-knee room measured from the center of the seating position, from the front of one seat back horizontally across the highest part of the seat to a vertical surface immediately in front, shall be a minimum of 26 in. At all seating positions in paired transverse seats immediately behind other seating positions, hip-to-knee room shall be no less than 27 in.

TS 50.3.2 Foot Room

Foot room, measured at the floor forward from a point vertically below the front of the seat cushion, shall be no less than 14 in. Seats immediately behind the wheel housings and modesty panels may have foot room reduced.

TS 50.4 Structure and Design

Comply ____ Do Not Comply ____

The passenger seat frame and its supporting structure shall be constructed and mounted to maximize that space to increase wheelchair maneuvering room and is completely free of obstructions to facilitate cleaning. Seats, structures and restraints around the securement area should not infringe into the mobility device envelope or maneuverability. The transverse seat structure shall be fully cantilevered from the sidewall with sufficient strength for the intended service. The lowest part of the seat assembly that is within 12 in. of the aisle shall be at least 10 in. above the floor. Folding seats used in wheelchair securement areas, as well as, transverse seats mounted in locations at which cantilevered installation is precluded by design or structure, or both, need not be cantilevered. All seat support structures shall be free of sharp edges.

The underside of the seat and the sidewall shall be configured to prevent debris accumulation and the transition from the seat underside to the bus sidewall to the floor cove radius shall be smooth. All transverse objects—including seat backs, modesty panels, and longitudinal seats—in front of forward-

facing seats shall not impart a compressive load in excess of 1,000 lbs. onto the femur of passengers ranging in size from a 5th-percentile female to a 95th-percentile male during a 10g deceleration of the bus. This deceleration shall peak at 0.05 +/- 0.015 seconds from initiation. Permanent deformation of the seat resulting from two (2) 95th-percentile males striking the seat back during this 10g deceleration shall not exceed 2 in., measured at the aisle side of the seat frame at height H. The seat back should not deflect more than 14 in., measured at the top of the seat back, in a controlled manner to minimize passenger injury. Structural failure of any part of the seat or sidewall shall not introduce a laceration hazard.

The seat assembly shall withstand static vertical forces of 500 lbs. applied to the top of the seat cushion in each seating position with less than ¼ in. permanent deformation in the seat or its mountings. The seat assembly shall withstand static horizontal forces of 500 lbs. evenly distributed along the top of the seat back with less than ¼ in. permanent deformation in the seat or its mountings. The seat backs at the aisle position and at the window position shall withstand repeated impacts of two 40-lb. sandbags without visible deterioration. One sandbag shall strike the front 40,000 times and the other sandbag shall strike the rear 40,000 times. Each sandbag shall be suspended on a 36 in. pendulum and shall strike the seat back 10,000 times each from distances of 6, 8, 10 and 12 inches. Seats at both seating positions shall withstand 4,000 vertical drops of a 40-lb. sandbag without visible deterioration. The sandbag shall be dropped 1,000 times each from heights of 6, 8, 10 and 12 inches. Seat cushions shall withstand 100,000 randomly positioned 3½ in. drops of a squirming, 150-lb., smooth-surfaced, buttocks-shaped striker with only minimal wear on the seat covering and no failures to seat structure or cushion suspension components.

The back of each transverse seat shall incorporate a handhold no less than 7/8 in. in diameter for standees and seat access/egress. The handhold shall not be a safety hazard during severe decelerations. The handhold shall extend above the seat back near the aisle so that standees shall have a convenient vertical assist, no less than 4 in. long that may be grasped with the full hand. This handhold shall not cause a standee using this assist to interfere with a seated 50th-percentile male passenger. The handhold shall also be usable by a 5th-percentile female, as well as by larger passengers, to assist with seat access/egress for either transverse seating position. The upper rear portion of the seat back and the seat back handhold immediately forward of transverse seats shall be padded and/or constructed of energy-absorbing materials. During a 10g deceleration of the bus, the HIC number (as defined by SAE Standard J211a) shall not exceed 400 for passengers ranging in size from a 5th-percentile female through a 95th percentile male. The seat back handhold may be deleted from seats that do not have another transverse seat directly behind and where a vertical assist is provided. Armrests shall not be included in the design of transverse seats.

Longitudinal seats shall be the same general design as transverse seats but without seat back handholds. Longitudinal seats may be mounted on the wheelhouses. Armrests shall be included on the ends of each set of longitudinal seats except on the forward end of a seat set that is immediately to the rear of a transverse seat, the operator's barrier, or a modesty panel, when these fixtures perform the function of restraining passengers from sliding forward off the seat. Armrests are not required on longitudinal seats located in the wheelchair parking area that fold up when the armrest on the adjacent fixed longitudinal seat is within 1½ to 3½ in. of the end of the seat cushion. Armrests shall be located from 7 to 9 in. above the seat cushion surface. The area between the armrest and the seat cushion shall be closed by a barrier or panel. The top and sides of the armrests shall have a minimum width of 1 in. and shall be free from sharp protrusions that form a safety hazard.

Seat back handhold and armrests shall withstand static horizontal and vertical forces of 250 lbs. applied anywhere along their length with less than ¼ in. permanent deformation. Seat back handhold and armrests shall withstand 25,000 impacts in each direction of a horizontal force of 125 lbs. with less than ¼ in. permanent deformation and without visible deterioration.

The Contractor shall provide a test report at the City's request fully documenting compliance with all the requirements defined above upon request. The test report shall contain a record of all testing activities,

test diagrams, testing equipment, as well as test data related to loads, deflections and permanent deformation of the seat assembly. The report shall include a statement of compliance with the requirements of this section of these Technical Specifications.

TS 50.5 Construction and Materials

Comply _____ Do Not Comply _____

Seats shall be constructed with materials that comply with the physical test. Selected materials shall minimize damage from vandalism and shall reduce cleaning time. The seats shall be attached to the frame with tamperproof fasteners. Coloring shall be consistent throughout the seat material, with no visually exposed portion painted. Any visually exposed or metal touching the sides or the floor of the bus shall be stainless steel. Seat structure, shell, frame, backs, handholds, and mounting hardware shall be constructed of stainless steel or City reviewed equal. The seat, pads and cushions shall be contoured for individuality, lateral support and maximum comfort and shall fit the framework to reduce exposed edges.

The minimum radius of any part of the seat back, handhold or modesty panel in the head or chest impact zone shall be a nominal ¼ inches. The seat back and seat back handhold immediately forward of transverse seats shall be constructed of stainless steel material. Complete seat assemblies shall be interchangeable to the extent practicable.

Thickness of the transverse seat backs shall be minimized at the bottom to increase passenger knee room and passenger capacity. The area between the longitudinal seat backs and the attachment to the bus sidewalls shall be designed to prevent debris accumulation.

The City will select the seat fabric and if cost effective supply fabric to Contractor.

TS 50.6 Seat Inserts

Comply _____ Do Not Comply _____

The seat and cushions shall be contoured for individuality, lateral support and maximum comfort and shall fit the framework to reduce exposed edges. Seating and interior trim shall have features to improve passenger comfort. Seats back and bottom inserts shall be securely attached and yet shall be detachable by means of a simple release mechanism so that they are easily removable by the maintenance staff but not by passengers. To the extent practicable, seat inserts shall be interchangeable throughout the bus. Materials shall have high resistance to tearing, flexing and wetting.

Seat covering materials shall be selected based on durability, ease of maintenance, pleasing texture and appearance. Seat fabric shall be Camira (Holdsworth) or City reviewed equal. Design and color shall be defined by City prior to the production of buses. The rear of the seat back and seat frame shall be enclosed by a stainless steel panel of a one-piece design. The seat cushion assemblies (seat back and bottom) shall be individually upholstered with no polyurethane foam.

Provision, such as a small grommetted hole, to allow drainage shall not be incorporated into seat insert.

TS 51. Passenger Assists

Comply _____ Do Not Comply _____

Passenger assists in the form of full grip, vertical stanchions or handholds shall be provided for the safety of standees and for ingress/egress. Passenger assists shall be convenient in location, shape and size for both the 95th-percentile male and the 5th-percentile female standee. Starting from the entrance door and moving anywhere in the bus and out the exit door, a vertical assist shall be provided either as the vertical portion of the seat back assist or as a separate item so that a 5th-percentile female passenger may easily move from one assist to another using one hand and the other without losing support. All handholds and stanchions shall be a mix of stainless steel/powder coated at the front doorway, and at interior steps for bi-level, final colors to be determined during design review.

TS 51.1 General

Comply _____ Do Not Comply _____

Excluding those mounted on the seats and doors, the assists shall have a cross-sectional diameter between 1¼ and 1½ in. or shall provide an equivalent gripping surface with no corner radii less than ¼ inches. All passenger assists shall permit a full hand grip with no less than 1½ in. of knuckle clearance around the assist. Passenger assists shall be designed to minimize catching or snagging of clothes or personal items and shall be capable of passing the NHTSA Drawstring Test.

Any joints in the assist structure shall be underneath supporting brackets and securely clamped to prevent passengers from moving or twisting the assists. Passenger assists shall be designed to minimize glare in the Operator's area to the extent possible. With the exception of seat and door handholds, all areas of the passenger assists that are handled by passengers including functional components used as passenger assists shall be of anodized aluminum or stainless steel. Seat handholds may be of the same construction and finish as the seat frame. Door-mounted passenger assists shall be of anodized aluminum, stainless steel or powder-coated metal. Connecting tees and angles may be powder-coated metal castings, final colors to be determined during design review. Assists shall withstand a force of 300 lbs. applied over a 12 in. lineal dimension in any direction normal to the assist without permanent visible deformation. All passenger assist components, including brackets, clamps, screw heads and other fasteners used on the passenger assists shall be designed to eliminate pinching, snagging and cutting hazards and shall be free from burrs or rough edges.

TS 51.2 Front Doorway Assist

Comply _____ Do Not Comply _____

Front doors, or the entry area, shall be fitted with ADA-compliant assists. Assists shall be as far outward as practicable, but shall be located no farther inboard than 6 in. from the outside edge of the entrance step and shall be easily grasped by a 5th-percentile female boarding from street level, no less than ¾ in. in width and shall provide at least 1½ inches of knuckle clearance between the assists and their mounting. Door assists shall be functionally continuous with the horizontal front passenger assist and the vertical assist and the assists on the wheel housing or on the front modesty panel.

TS 51.3 Vestibule

Comply _____ Do Not Comply _____

The aisle side of the operator's barrier, the wheel housings and when applicable the modesty panels shall be fitted with vertical passenger assists that are functionally continuous with the overhead assist and that extend to within 36 in. of the floor. These assists shall have sufficient clearance from the barrier to prevent inadvertent wedging of a passenger's arm.

A horizontal passenger assist shall be located across the front of the bus and shall prevent passengers from sustaining injuries on the fare collection device or windshield in the event of a sudden deceleration. Without restricting the vestibule space, the assist shall provide support for a boarding passenger from the front door through the fare collection procedure. Passengers shall be able to lean against the assist for security while paying fares. The assist shall be no less than 36 in. above the floor. The assists at the front of the bus shall be arranged to permit a 5th-percentile female passenger to easily reach from the door assist, to the front assist, to vertical assists on the operator's barrier, wheel housings or front modesty panel.

TS 51.4 Rear Doorway Assist

Comply _____ Do Not Comply _____

Vertical assists that are functionally continuous with the overhead assist shall be provided at the aisle side of the transverse seat immediately forward of the rear door and on the aisle side of the rear door modesty panel(s). Passenger assists shall be provided on modesty panels that are functionally continuous with the rear door assists. Rear doors, or the exit area, shall be fitted having a cross-sectional diameter between 1¼ and 1½ in. or providing an equivalent gripping surface with no corner

radii less than ¼ in., and shall provide at least 1½ in. of knuckle clearance between the assists and their mounting. The assists shall be designed to permit a 5th-percentile female to easily move from one assist to another during the entire exiting process. The assists shall be located no farther inboard than 6 in. from the outside edge of the rear doorway.

TS 51.5 Overhead Assist

Comply _____ Do Not Comply _____

Except forward of the standee line and at the rear door, a continuous, full-grip, overhead assist shall be provided. This assist shall be convenient to standees anywhere in the bus and shall be located over the center of the aisle seating position of the transverse seats. The assist shall be no less than 70 in. above the floor.

Split design grab straps shall be provided for sections where vertical assists are not available and for the use by passengers that cannot reach to 70 in. and the quantity has to be equal to twenty-five (25) percent the allowable number of standees. The City shall determine the hand strap's final location. No more than 5 percent of the full grip feature shall be lost due to assist supports.

Overhead assists shall simultaneously support 150 lbs. on any 12-inch length.

TS 51.6 Longitudinal Seat Assists

Comply _____ Do Not Comply _____

Longitudinal seats shall have vertical assists located between every other designated seating position, except for seats that fold/flip up to accommodate wheelchair securement. Assists shall extend from near the leading edge of the seat and shall be functionally continuous with the overhead assist. Assists shall be staggered across the aisle from each other where practicable and shall be no more than 52 in. apart or functionally continuous for a 5th percentile female passenger.

TS 51.7 Wheel Housing Barriers/Assists

Comply _____ Do Not Comply _____

Unless passenger seating is provided on top of wheel housings, passenger assists shall be mounted around the exposed sides of the wheel housings (and propulsion compartments if applicable), which shall also be designed to prevent passengers from sitting on wheel housings. Such passenger assists shall also effectively retain items, such as bags and luggage, placed on top of wheel housings.

TS 52. Passenger Doors

TS 52.1 General

Comply _____ Do Not Comply _____

Two doorways shall be provided on the curbside of the bus for passenger ingress and egress. Doorways will be provided in the locations and styles as follows. Passenger doors and doorways shall comply with ADA requirements. Doors shall be fully electrically powered. Doors will be provided in the locations and styles as follows. Passenger doors and doorways shall comply with ADA requirements.

The closing edge of each door panel shall have no less than 2 in. of soft weather stripping. The doors, when closed, shall be effectively sealed and the hard surfaces of the doors shall be at least 4 in. apart. The combined weather seal and window glazing elements of the front door shall not exceed 10 deg. of binocular obstruction of the operator's view through the closed door.

TS 52.1.1 Front Door

The Front doors shall be slide glide and shall be located forward of the front wheels and under direct observation of the operator.

TS 52.1.2 Rear Door

The rear doors shall be plug door design with yellow hand bars and shall be located ahead of the center rear wheels.

TS 52.2 Materials and Construction

Comply _____ Do Not Comply _____

Structure of the doors, their attachments, inside and outside trim panels and any mechanism exposed to the elements shall be corrosion resistant. Door panel construction shall be of corrosion-resistant metal or reinforced non-metallic composite materials. When fully opened, the doors shall provide a firm support and shall not be damaged if used as an assist by passengers during ingress or egress. The front leaves of the passenger doors shall overlap the rear leaves. Door edges shall be sealed to prevent infiltration of exterior moisture, noise, dirt and air elements from entering the passenger compartment, to the maximum extent possible based on door types.

The closing edge of each door panel shall have no less than 2 in. of soft weather stripping. The doors, when closed, shall be effectively sealed, and the hard surfaces of the doors shall be at least 4 in. apart. The combined weather seal and window glazing elements of the front door shall not exceed 10 degrees of binocular obstruction of the driver's view through the closed door.

TS 52.3 Dimensions

Comply _____ Do Not Comply _____

FIGURE 6

Transit Bus Minimum Door Opening

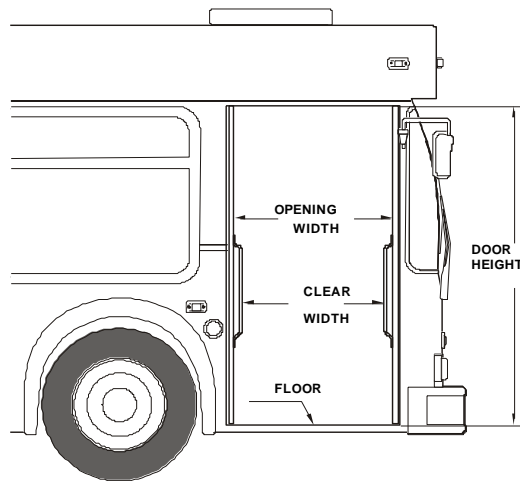

When open, the doors shall leave an opening no less than 75 in. in height. Any part of the front door shall not excursion outboard beyond the side of the bus. The rear door shall have a maximum outboard excursion of 10 in. beyond the side of the bus.

TS 52.3.1 Transit Coach Doors

Front door clear width shall be a minimum of 32 in. with the doors fully opened. Rear doors opening clear width shall be a minimum of 48 in. with the doors fully opened..

TS 52.4 Door Glazing

Comply _____ Do Not Comply _____

The full length of front and rear doors shall be glazed. The door panel glazing material shall have a nominal ¼ in. or 6 mm thick laminated safety glass conforming to the requirements of ANSI Z26.1 Test Grouping 2 and the Recommended Practices defined in SAE J673. Glazing material in the rear

doorway door panels shall be the same material, thickness and color as the side windows. Door glazing shall be easily replaceable. Glazing material in the rear doorway door panels shall be defined by the City. The combined weather seal and window glazing elements of the front door shall not exceed 10 deg. of binocular obstruction of the operator's view through the closed door. ThermoGuard windows is currently the City's standard, other manufacturers and models with equal or greater properties and/or durability may be submitted for review by the City.

TS 52.5 Door Projection

Comply _____ Do Not Comply _____

TS 52.5.1 Exterior

The exterior projection of the front doors beyond the side of the bus shall be minimized and shall not block the line of sight of the rear exit door via the curb side mirror when the doors are fully open. The exterior projection of both doors shall be minimized and shall not exceed 6½ in. during the opening or closing cycles or when doors are fully opened.

TS 52.5.2 Interior

Projection inside the bus shall not cause an obstruction of the rear door mirror or cause a hazard for standees.

TS 52.6 Door Height Above Pavement

Comply _____ Do Not Comply _____

It shall be possible to open and close either passenger door when the bus loaded to gross vehicle weight rating is not knelt and parked with the tires touching an 8 in. high curb on a street sloping toward the curb so that the street-side wheels are 5 in. higher than the right-side wheels.

TS 52.7 Closing Force

Comply _____ Do Not Comply _____

Closing door edge speed shall not exceed 12 in. per second, and opening door speed shall not exceed 19 in. per second. Power doors shall not slam closed under any circumstance, even if the door is obstructed during the closing cycle. If a door is obstructed during the closing cycle, the pressure exerted on the obstruction shall not increase once initial contact has been made.

The doors shall be equipped with a sensitive edge or other obstruction sensing system. If a door is obstructed during the closing cycle, the pressure exerted on the obstruction shall not increase once initial contact has been made, the doors will stop and/or reverse direction prior to imparting a 10-lb. force on 1 sq. in. of that obstruction.

Power-close rear doors shall be equipped with an obstruction sensing system such that if an obstruction is within the path of the closing doors, the doors will stop and/or reverse direction prior to imparting a 10-lb force on 1 sq. in. of that obstruction. If a contactless obstruction sensing system is employed, it shall be capable of discriminating between the normal doorway environment and passengers or other obstructions within the doorway, and of altering the zones of detection based upon the operating state of the door system.

Doors closed by a return spring or counterweight-type device shall be equipped with an obstruction-sensing device that, at a minimum, alerts the operator if an obstruction is detected between the closing doors. Doors closed by a return spring or counterweight type device, when unlocked, shall be capable of being pushed to the point where the door starts to open with a force not to exceed 25 lbs. applied to the center edge of the forward door panel.

TS 52.7.1 Passenger Door Obstruction Sensing

Power-close rear doors shall be equipped with an obstruction-sensing system such that if an obstruction is within the path of the closing doors, the doors will stop and/or reverse direction prior to

imparting a 10-lb force on 1 sq. in. of that obstruction. Whether or not the obstruction sensing system is present or functional it shall be capable of discriminating between the normal doorway environment and passengers or other obstructions within the doorway, and of altering the zones of detection based upon the operating state of the door system.

TS 52.8 Actuators

Comply _____ Do Not Comply _____

Vapor electric open doors actuators with pneumatic sensitive edge and optical pressure switch is currently the City's standard, other manufacturers and models with equal or greater properties and/or durability may be submitted for review by the City. Doors shall open or close completely in not more than 3.5 seconds from the time of control actuation and shall be subject to the closing force requirements.

Door actuators shall be adjustable so that the door opening and closing speeds can be independently adjustable to satisfy the above requirements. Actuators and the complex door mechanism shall be concealed from passengers but shall be easily accessible for servicing. The City shall approve access panels for actuator. The door actuators shall be rebuildable. If powered by compressed air, exhaust from the door system shall be routed below the floor of the bus to prevent accumulation of any oil that may be present in the air system and to muffle sound.

Door actuators and associated linkages shall maximize door holding forces in the fully open and fully closed positions to provide firm, non-rattling, non-fluttering door panels while minimizing the force exerted by the doors on an obstruction midway between the fully open and closed positions.

The rear door actuator(s) shall be under the complete control of the vehicle operator and shall open and close in response to the position of the operator's door control. The rear doors shall be passenger-controlled. The vehicle operator shall unlock and enable the opening mechanism, which shall be annunciated by illumination of a green light near the door. After enabling and unlocking, the doors shall be opened by either the passenger manually pushing the door open, or by a powered mechanism actuated by passenger activation of a touch bar or touch switch, or by passenger activation of a contactless sensing system. A switch located within reach of the seated operator shall, when actuated, restore rear door function to complete operator control, as described in the "Default."

Doors that employ a "swing" or pantograph geometry and/or are closed by a return spring or counterweight-type device shall be equipped with a positive mechanical holding device that automatically engages and prevents the actuation mechanism from being back-driven from the fully closed position. The holding device shall be overcome only when the operator's door control is moved to an "Exit Door Enable" position and the vehicle is moving at a speed of less than 2 mph, or in the event of actuation of the emergency door release.

Locked doors shall require a force of more than 300 lbs. to open manually. When the locked doors are manually forced to open, damage shall be limited to the bending of minor door linkage with no resulting damage to the doors, actuators or complex mechanism.

TS 52.9 Emergency Operation

Comply _____ Do Not Comply _____

In the event of an emergency, it shall be possible to manually open doors from inside the bus using a force of no more than 25 lbs. after actuating an unlocking device at each door. The unlocking device shall be clearly marked as an Emergency Only device and shall require two distinct actions to actuate. The respective door emergency unlocking device shall be accessible from the entrance and exit doorway step well areas. When this emergency device is actuated, the door interlock brake system shall apply to stop the Coach. The unlocking device shall be easily reset by the operator without special tools or opening the door mechanism enclosure. Doors that are required to be classified as "Emergency Exits" shall meet the requirements of FMVSS 217.

TS 52.10 Door Control

Comply _____ Do Not Comply _____

The 5 position door control shall be located on the street side in the operator's area within the hand reach envelope described in SAE Recommended Practice J287, "Operator Hand Control Reach." The operator's door control shall provide tactile feedback to indicate commanded door position and resist inadvertent door actuation. The front door shall remain in commanded state position even if power is removed or lost. Vapor digital controller with knob handle with 5 command switches is currently the City's standard, other manufacturers and models with equal or greater properties and/or durability may be submitted for review by the City.

To preclude movement of the bus while any door is open, an accelerator interlock shall lock the accelerator in the closed position and a brake interlock shall engage the service brake system when the any door control is activated. The interlock system shall also energize the emergency four-way flasher system. When the interlock system has been activated, it will not release until a light application and release of the brake pedal is made.

The control device shall be protected from moisture. Mounting and location of the door control device handle shall be designed so that it is within comfortable, easy arm's reach of the seated operator. The door control device handle shall be free from interference by other equipment and have adequate clearance so as not to create a pinching hazard.

Position of the door control handle shall result in the following operation of the front and rear doors:

- **Center position:** Front door closed, rear door(s) closed or set to lock.
- **First position forward:** Front door open, rear door(s) closed or set to lock.
- **Second position forward:** Front door open, rear door(s) open or set to open.
- **First position back:** Front door closed, rear door(s) open or set to open.
- **Second position back:** Front door open, rear door(s) open or set to open.

TS 52.10.1 Door Open/Close

Operation of, and power to, the front passenger doors shall be completely controlled by the operator. Power to rear doors shall be controlled by the operator. After enabling, the rear doors shall be opened by the passenger. A switch shall be provided to enable the driver to obtain full control of the rear doors.

A control or valve in the operator's compartment shall shut off the power to, and/or dump the power from, the front door mechanism to permit manual operation of the front door. A master door switch that is not within reach of the seated operator when set in the "Off" position shall close the doors, deactivate the door control system, release the interlocks, and permit only manual operation of the doors.

TS 52.11 Door Interlocks

Comply _____ Do Not Comply _____

To prevent opening of passenger doors while the bus is in motion, a speed sensor shall be integrated with the door controls to prevent the doors from being enabled or opened unless the bus speed is less than 2 mph.

To preclude movement of the bus, an accelerator interlock shall lock the accelerator in the closed position, and a brake interlock shall engage the service brake system to stop movement of the bus when the operator's door control is moved to an enable or open position, or either door panel is opened more than 3 in. from the fully closed position (as measured at the leading edge of the door panel). The interlock engagement shall bring the bus to a smooth stop and shall be capable of holding a fully loaded bus on a 6 percent grade, with the transmission in gear, until the interlocks are released. These interlock functions shall be active whenever the vehicle Master Run Switch is in any run position.

All door systems employing brake and accelerator interlocks shall be supplied with supporting Failure Mode Effects Analysis (FEMA) documentation, which demonstrates that failure modes are of a failsafe type, thereby never allowing the possibility of release of interlock while an interlocked door is in an

unsecured condition, unless the door master switch has been actuated to intentionally release the interlocks. An interlock disconnect switch shall be installed in the head sign compartment for troubleshooting.

TS 53. Accessibility Provisions

Comply _____ Do Not Comply _____

The Contractor shall design and construct the bus in accordance with all requirements defined in 49 CFR, Part 38, Subpart B: ADA Accessibility Specifications for Transportation Vehicles – Buses, Vans and Systems. The Contractor shall provide space and body structural provisions at the front and rear doors of the bus to accommodate the wheelchair loading system. Prior to submission of bid, the Contractor shall provide a plan, including layout drawings for entry, maneuvering, parking, and exiting of wheelchair passengers, to show compliance with ADA regulations. It shall provide special equipment and features to meet all ADA requirements to enable the buses to be accessible to the non-ambulatory, elderly, and disabled, including those confined to a wheelchair up to 28.5 inches wide and 48 inches long.

TS 53.1 Wheelchair Ramp Loading Systems

Comply _____ Do Not Comply _____

A self-contained fold-out type wheelchair ramp system, compliant with requirements defined in most recent revision of 49 CFR Part 38, Subpart B, §38.23c, shall be provided. Lift-U LU18 dual mode front door ramp is currently the City's standard, other manufacturers and models with equal or greater properties and/or durability may be submitted for review by the City.

An automatically-controlled, power-operated ramp system compliant to requirements defined in 49 CFR Part 38, Subpart B, §38.23c shall provide ingress and egress quickly, safely and comfortably, both in forward and rearward directions, for a passenger in a wheelchair from a level street or curb.

The ramp(s) shall be of a simple hinged, flip-out type. The ramp(s) shall have a minimum clearance width of 34 inches.

The wheelchair loading system shall be located at the front door, with the ramp being of a simple hinged, flip-out type design being capable of deploying to the ground at a maximum 6:1 slope. The wheelchair lift control system must be capable of receiving multiplex command from vehicle interlocks.

The transition from roadway or sidewalk and the transition from lift to coach floor shall not exceed ¼ inch. The lift angle shall be; a maximum of 1:4 if the height of the vehicle floor is 3 in. or less above a 6 inch curb; maximum 1:6 if vehicle floor is 6 in. or less, but greater than 3 inches; a maximum of 1:8 if the vehicle floor is 9 in. or less, but greater than 6 inches. Thresholds greater than ¼ in. high shall be beveled with a slope no greater than 1:2. All gaps between vehicle and ramp shall not exceed 5/8 inch. Lift 30 in. or longer shall support a load of 600 lbs., placed at the centroid of the ramp distributed over an area of 26 in. by 26 in., with a safety factor of at least 3, based on the ultimate strength of the material. Deployment or storage of the ramp shall require no more than 15 seconds.

The ramp(s) shall provide ingress and egress quickly, safely and comfortably, both in forward and rearward directions, for a passenger in a wheelchair from a level street or curb. The ramp(s) shall accommodate both four-wheel and three-wheel mobility aids. A passenger departing or boarding via the ramp shall be able to easily obtain support by grasping the passenger assist located on the doors or other assists provided for this purpose. The platform shall be designed to protect the ramp from damage and people on the sidewalk from injury during the extension/retraction or lowering/raising phases of operation.

When the system is not in use, the passageway shall appear normal and shall not interfere with the use of the doorway by the ambulatory. In the stored position of the ramp, no tripping hazards shall be present and any resulting gaps shall be minimized.

TS 53.1.1 Wheelchair Ramp Control

The controls for the loading system shall be located near the door in which the system is located. A hooded on/off toggle switch, shall be located at the driver's console/dashboard panel to disable the loading system.

Ramp controls shall be simple to operate with no complex phasing operations required, and the loading system operation shall be under the surveillance and complete control of the operator. If the loading system and controls are at the rear doors, then a keyed switch shall be provided in the operator's area to disable the loading system.

The Wheelchair Ramp control system must be capable of receiving multiplex commands from vehicle interlocks. The bus shall be prevented from moving during the loading or unloading cycle by a throttle and brake interlock system. The loading system shall be inhibited from stowing/deploying when a passenger is on the ramp/platform.

The unit shall be equipped with a "non-zeroing" historical counter controlled, recorded and operated within the PLC. The extracted data shall be time stamped and downloadable into a Windows PC environment, Excel or other format, for analysis (to evaluate activity daily, monthly, time of the day, day of the week, etc.).

A manual override system shall permit unloading a wheelchair and storing the device with ease in the event of a primary power failure. The manual operation of the ramp shall not require more than 20 lbs. of force.

TS 53.1.2 Ramp and Sub-Frame Construction

The lift shall have a minimum load capacity of 600 pounds. It shall be capable of operating repeatedly with 600-pound dynamic loads, without failure, malfunction, or physical deformation.

The ramp and sub-frame shall be so installed as to provide adequate clearance of steering components and other obstructions, while providing easy removal of the ramp system from the coach. Mud flaps shall be installed in front of front wheels to prevent foreign material from entering lift mechanism. A protective tray shall be provided that prevents foreign material from entering components or mechanisms.

The ramp shall be installed in such a way as to provide ground clearance for the bus as stated in TS 12.6 Underbody Clearance. The installation shall also allow the ramp to be operational when the bus is on a high crown road. The platform shall be level on the sidewalk when the bus is five (5) deg. off level.

TS 53.1.3 Ramp Surface

The ramp surface shall be continuous, slip resistant, and free of any protrusions over ¼ in. high. The loading platform shall be covered with a Linex or reviewed equal finish replaceable or renewable nonskid material. Each side of the ramp shall have barriers with a minimum height of 2 inches.

TS 53.1.4 Ramp Safety Barriers

Side safety barriers shall be provided on each side of the ramp and shall be a minimum of 2 in. in height to prevent the wheelchair from rolling off the sides during loading or unloading. Side safety barriers shall be painted "Caution Yellow".

TS 53.1.5 Ramp Lighting

Lights shall be provided above the doorway equipped with the Wheelchair ramp system to floodlight the loading area. The lights shall illuminate when the ramp system is in operation and shall illuminate the street surface to a level of no less than 1 foot-candle for a distance of three-feet square outward from the lowest step tread edge.

TS 53.1.6 Ramp Reliability and Maintenance

The device shall function without failure or adjustment for 500 cycles or 5,000 miles in all weather conditions on the design operating profile when activated once during the idle phase

The ramp assembly components shall be replaceable within 30 minutes by a mechanic.

TS 53.2 Wheelchair Accommodation Locations

Comply _____ Do Not Comply _____

NOTE: Agency will approve acceptable securement system.

One forward-facing and one rearward-facing locations shall be provided as close to the wheelchair loading system as practical, shall provide parking space and securement system compliant with ADA requirements for a passenger in a wheelchair. Additional equipment, including passenger restraint seat belts, shoulder harnesses and wheelchair securement devices shall be provided for each wheelchair passenger. All belt assemblies must stow up and out of the way when not in use. The basic securement system shall be a passive wheel lock when applicable, and to include belting system for conventional wheelchairs as well as 3-wheel scooters. Antiskid flooring material, subject to the City's approval, is required at all wheelchair location. All passenger securement devices must be stowed off the floor and out of the way when not in use. The City's current wheelchair accommodation configuration is manufactured by Q'Straint consist of the WF1-Q'POD forward-facing system on the street side with a Quantum rearward-facing system on the curbside. Other manufacturers and models with equal or greater properties and/or durability may be submitted for review by the City.

TS 53.3 Interior Circulation

Comply _____ Do Not Comply _____

Maneuvering room inside the bus shall accommodate easy travel for a passenger in a wheelchair from the loading device through the bus to the designated securement area and back out. It shall be designed so that no portion of the wheelchair or its occupant protrudes into the normal aisle of the bus when parked in the designated parking space(s). When the positions are fully utilized, an aisle space of no less than 20 in. shall be maintained. As a guide, no width dimension should be less than 34 inches. Areas requiring 90 deg. turns of wheelchairs should have a clearance arc dimension no less than 45 in., and in the parking area where 180 deg. turns are expected, space should be clear in a full 60 in. diameter circle. A vertical clearance of 12 in. above the floor surface should be provided on the outside of turning areas for wheelchair footrests.

The Contractor shall submit a scaled drawing with clear and complete dimensions indicating seat layout, wheelchair turning radius, wheelchairs in parked position.

TS 54. Mirrors

TS 54.1 Exterior Mirrors

Comply _____ Do Not Comply _____

The bus shall be equipped with corrosion-resistant, outside rearview mirrors mounted on either side of the bus with stable supports to minimize vibration. Exterior mirrors shall be installed with a breakaway mounting system. Mirrors shall be firmly attached to the bus to minimize vibration and to prevent loss of adjustment with a breakaway mounting system. Mirrors shall permit the operator to view the roadway along the sides of the bus, including the rear wheels and shall be adjustable both in the horizontal and vertical directions to view the rearward scene. Mirrors should be positioned to prevent blind spots. Mirrors shall retract or fold sufficiently to allow bus washing operations. Both streetside and curbside mirrors shall be high mounted with a turn signal integrated into the mirror. Mirrors shall retract or fold sufficiently to allow bus washing operations but avoid contact with windshield.

TS 54.2 Interior Mirrors

Comply _____ Do Not Comply _____

Mirrors shall be provided for the operator to observe passengers throughout the bus without leaving the operator's seat and without shoulder movement. With a full standee-load, including standees in the vestibule, the operator can observe passengers in the front and by the rear door, anywhere in the aisle and in the rear seats. Inside mirrors shall not be in the line of sight to the right outside mirror. Location and type of mirrors shall be reviewed by the City.

TS 55. Windows

TS 55.1 General

Comply _____ Do Not Comply _____

A minimum of 10,000 sq. in. of window area, including operator and door windows, shall be required on each side of the standard configuration bus. ThermoGuard windows are currently the City's standard, other manufacturers and models with equal or greater properties and/or durability may be submitted for review by the City.

TS 55.2 Windshield

Comply _____ Do Not Comply _____

The windshield shall permit an operator's field of view as referenced in SAE Recommended Practice J1050. The vertically upward view shall be a minimum of 15 deg., measured above the horizontal and excluding any shaded band. The vertically downward view shall permit detection of an object 3½ ft. high no more than 2 ft. in front of the bus. The horizontal view shall be a minimum of 90 deg. above the line of sight. Any binocular obscuration due to a center divider may be ignored when determining the 90 deg. requirement, provided that the divider does not exceed a 3 deg. angle in the operator's field of view. Windshield pillars shall not exceed 10 deg. of binocular obscuration. The windshield shall be designed and installed to minimize external glare as well as reflections from inside the bus. The windshield shall be designed and installed to minimize external glare as well as reflections visible in the windshield immediately forward of the operator's barrier. Reflections in the remainder of the windshield shall be minimized. Windshield glare/reflections shall be subject to the approval of the California Highway Patrol.

TS 55.2.1 Windshield Glazing

The windshield glazing material shall have a ¼ in. nominal thickness laminated safety glass conforming to the requirements of ANSI Z26.1 Test Grouping AS-1 and the recommended practices defined in SAE J673. The glazing material shall have single density tint except for the upper portion of the windshield above the operator's field of view which shall have a dark green, shaded band. The green shaded band shall have a minimum luminous transmittance of six (6) percent when tested in accordance to ASTM D-1003. Partial band required to allow view for camera and mirror viewing.

TS 55.2.2 Windshield Installation

The windshield shall be easily replaceable by removing zip locks from the windshield retaining moldings. Bonded in place windshields shall not be used. Winglets may be bonded

TS 55.3 Operator's Side Window

Comply _____ Do Not Comply _____

The operator's side window shall be the sliding type, requiring only the rear half of sash to latch upon closing and shall open sufficiently to permit the seated operator to easily adjust the street side outside rearview mirror. When in an open position, the window shall not rattle or close during braking. This window section shall slide in tracks or channels designed to last the service life of the bus. The operator's side window shall not be bonded in place and shall be easily replaceable.

The operator's view, perpendicular through operator's side window glazing, should extend a minimum of 33 in. (840 mm) to the rear of the Heel Point on the accelerator, and in any case must accommodate a 95th percentile male operator. The view through the glazing at the front of the assembly should begin not more than 26 in. (560 mm) above the operator's floor to ensure visibility of an under-mounted convex mirror. Operator's window construction shall maximize ability for full opening of the window. Driver's side window, flush mounted - with single sliding sash (forward), with exterior and interior handles. Non-egress.

The design shall prevent sections from freezing closed in the winter. Light transmittance shall be 75 percent on the glass area below 53 in. from the operator platform floor. On the top-fixed-over-bottom-slider configuration, the top fixed area above 53 in. may have a maximum 5 percent light transmittance.

TS 55.3.1 Operator's Side Window Glazing

Glazing in the window assembly shall be replaced without removing the window from its installed position on the bus or manipulation of the rubber molding surrounding the glazing. The glazing shall be held in place mechanically by a formed metal extruded ring constructed to last the life of the vehicle.

The driver's side window glazing material shall have a ¼ in. nominal thickness laminated safety glass conforming to the requirements of ANSI Z26.1-1996 Test Grouping AS-2 and the recommended practices defined in SAE J673. The glazing tint shall be blue in color with 70% light transmittance or greater and comply with AS2 DOT requirements, blocking no less than 99% of the UV and 93% of the infrared heat. The design shall prevent sections from freezing closed in the winter.

TS 55.4 Side/Passenger and Door Windows

Comply _____ Do Not Comply _____

Windows shall be hidden frame, flush Euro-Look". Arrow Global and ThermoGuard configuration are currently the City's standard, other manufacturers and models with equal or greater properties and/or durability may be submitted for review by the City. Window construction and glazing must comply with FMVSS No. 217. All side windows, except windows in passenger doors and those smaller than 500 sq. in., shall have window panels that passengers can open with adequate exits for quick passenger escape during emergency conditions. All emergency exits shall comply with applicable codes and requirements and the best industry practice, to including NHTSA TP-217TB-00 06/25/2002. Window panels that passengers can open shall be equipped with latches that secure the window in the fully open and fully closed positions.

All side/passenger windows shall, at the time of delivery in Fresno, CA, have Transit Care Vandal Guards anti-graffiti or City reviewed equal anti-graffiti installed. This anti-vandalism provision shall be reviewed by the City.

Engineering drawings showing the design of the window system are to be submitted upon delivery of the coaches.

TS 55.4.1 Configuration

All side windows shall not be bonded in place, but shall be easily replaceable without disturbing adjacent windows and shall be mounted so that flexing or vibration from propulsion system operation or normal road excitation is not apparent. All aluminum and steel material will be treated to prevent corrosion. The windows shall be designed and constructed to enable removal and replacement in less than 15 minutes.

TS 55.4.2 Emergency Exit (Egress) Configuration

Large side windows shall be push out type, hinged at top for emergency escape. Sash shall be equipped with a positive locking device to prevent accidental opening. All push out windows shall have a minimum clear opening height of seventeen (17) inches and a minimum width of twenty-four (24) inches.

An identification plate with instructions for operating push-out sash shall be attached to the adjacent body panel next to each push out window. Escape latch handles shall be coated with red pliable plastic.

TS 55.4.3 Anti-Vandalism Liner

All glazing material aft of the standee line shall be equipped with necessary bracketry, fasteners and clear acrylic liner that shall be easily removable in the event of vandalism. The acrylic material shall be clear and shall have minimal effect on the transmittance of the underlying glazing. This material shall not be adversely affected by ultraviolet rays and shall withstand normal cleaning practices. The installation of the liner shall prevent clouding or fogging. A mechanic shall be able to easily remove and replace the acrylic liner without the use of any specialized tools in 5 minutes or less.

TS 55.4.4 Transom

Each operable side window shall incorporate an upper transom portion. The transom shall be between 25 and 35 percent of the total window area. The lower portion of the window shall be fixed. The transom portion shall be hinged along the lower edge and open inward.

TS 55.4.5 Glazing

ThermoGuard windows are currently the City's standard, other manufacturers and models with equal or greater properties and/or durability may be submitted for review by the City. Side windows glazing material shall have a minimum of 6mm nominal thickness laminated safety glass. The material shall conform to the requirements of ANSI Z26.1-1996 Test Grouping 2 and the recommended practices defined in SAE J673.

Windows on the bus sides and in the rear door shall be tinted a neutral color, complementary to the bus exterior. The maximum solar energy transmittance shall not exceed 37 percent, as measured by ASTM E-424. Luminous transmittance shall be no less than 9 percent as measured by ASTM D-1003. Windows over the destination signs shall not be tinted. Windows on the bus sides and in the rear door(s) shall be tinted a neutral color, complementary to the bus exterior. The maximum solar energy transmittance shall not exceed 37 percent, as measured by ASTM E-424, and the luminous transmittance shall be no less than 9 percent as measured by ASTM D-1003. Windows over the destination signs shall not be tinted. Passenger and door windows purposed for bus shall be tempered safety glass hidden frame windows type and shall blend and compliment the exterior body style. The glazing tint shall be blue in color with 70% light transmittance or greater and comply with AS2 DOT requirements, blocking no less than 99% of the UV and 93% of the infrared heat. All glass treatments, tint, and film must be permanent, within the glass and/or in the center membrane. Surface films are not permitted. SHGC and light transmission performance shall be defined by the National Fenestration Rating Council.

Front door windows shall be single density, laminated safety sheet glass and marked as such per ANSI specifications.

TS 55.5 Rear Window

A rear window shall be provided. The rear window shall be glazed with same material (including anti-vandalism provision) and tint as side windows. The glazing shall be set in rubber channels or be pushout type to meet FMVSS 217.

TS 56. Windshield Wipers and Washers

TS 56.1 Windshield Wipers

Comply _____ Do Not Comply _____

The bus shall be equipped with a Sprague, or City reviewed equal windshield wipers. The wipers shall be variable speed electric, wet arm, 24 volt models. There shall be one windshield wiper for each half of the windshield. For non-synchronized wipers, separate controls for each side shall be supplied. A variable intermittent feature shall be provided to allow adjustment of wiper speed for each side between

approximately 5 to 25 cycles per minutes. At 60 mph, no more than 10 percent of the wiped area shall be lost due to windshield wiper lift. For two-piece windshields, both wipers shall park along the center edges of the windshield glass. Windshield wiper motors and mechanisms shall be easily accessible for repairs or service. The fastener that secures the wiper arm to the drive mechanism shall be corrosion-resistant.

TS 56.2 Windshield Washers

Comply _____ Do Not Comply _____

The windshield washer system, when used with the wipers, shall deposit washing fluid evenly and completely wet the entire wiped area. The windshield washer system shall have a minimum 4-gallon reservoir, located for easy refilling from outside the bus. Reservoir pumps, lines and fittings shall be corrosion-resistant and the reservoir itself shall be translucent for easy determination of fluid level.

TS 57. Heating, Ventilating and Air Conditioning

TS 57.1 General

Comply _____ Do Not Comply _____

The Heating, Ventilation Air Conditioning (HVAC) units shall be a Thermo King all electric rear mounted system. Accessibility and serviceability of components shall be provided without requiring maintenance personnel to climb-up on the roof of the bus. All HVAC electric motors shall be brushless and each motor shall be serviced by a solid state controller. All electric boost pumps shall be brushless and seal less.

Hot coolant shall be delivered to the HVAC system, operator's defroster/heater and other heater cores by means of an auxiliary coolant pump, sized for the required flow, which is brushless and sealless having a minimum maintenance-free service life for both the brushless motor and the pump of at least 40,000 hours at full power.

Contractor shall provide separate heating, ventilation, and defroster system for the operator's area and the operator shall control the system.

The air conditioning system shall meet these performance requirements using either R407c.

TS 57.2 Capacity and Performance

Comply _____ Do Not Comply _____

The HVAC climate control system shall be capable of controlling the temperature and maintaining the humidity levels of the interior of the bus as defined in the following paragraphs.

With the bus running, at the design operating profile with corresponding door opening cycle, and carrying a number of passengers equal to 150 percent of the seated load, the HVAC system shall control the average passenger compartment temperature within arrange between 65 and 80° F, while maintaining the relative humidity to a value of 50 percent or less. The system shall maintain these conditions while subjected to any outside ambient temperatures within a range of 10 to 95° F and at any ambient relative humidity levels between 5 and 50 percent.

When the bus is operated in outside ambient temperatures of 95 to 115° F, the interior temperature of the bus shall be permitted to rise 0.5°F for each degree of exterior temperature in excess of 95° F. When the bus is operated in outside ambient temperatures in the range of -10 to 10° F, the interior temperature of the bus shall not fall below 55° F while the bus is running on the design operating profile.

Main heating system shall be thermostatically controlled and equipped with Vapor, or reviewed equal, mercury-type thermostat and water control valve. Heater-water pump shall operate only when thermostat or defroster requires heat. This system shall have a capacity of at least 110,000 BTU at 100 degrees water/air temperature differential. The system shall have a heat position on Thermo-controlled switch and a vent position for summer use.

System capacity testing, including pull-down/warm-up, stabilization and profile, shall be conducted in accordance to APTA's Recommended Practice "Transit Bus HVAC System Instrumentation and Performance Testing." Additional testing shall be performed as necessary to ensure compliance to performance requirements stated herein.

TS 57.2.1 Pull Down Test

The vehicle shall be instrumented to include four (4) thermocouples for the testing of the HVAC system, three (3) to be located four (4) feet above the floor on the center line of the Vehicle and one (1) to be located at the operators head level. The air conditioning portion of the HVAC system shall be capable of reducing the interior passenger compartment temperature at four (4) evenly spaced locations throughout the bus from 115 to 85°F +/- 3°F in less than 30 minutes after system engagement. That is all four (4) thermocouples must be at or below 73 degrees Fahrenheit in 30 minutes (not an average). Coolant temperature shall be within the normal operating range at the time of start-up of the cool-down test. During the cool-down period, the refrigerant pressure shall not exceed safe high-side pressures, and the condenser discharge air temperature, measured 6 in. from the surface of the coil, shall be less than 45°F above the condenser inlet air temperature. The appropriate solar load as recommended in the APTA "Recommended Instrumentation and Performance Testing for Transit Bus Air Conditioning System," representing 4 p.m. on August 21, shall be used. There shall be no passengers on board, and the doors and windows shall be closed.

After the vehicle passes Pull Down Test, an operational test shall be performed for informational purposes. This test shall be performed while the Vehicle is still heat soaked and instrumented, and shall consist of monitoring the Air Conditioning System for sixty (60) minutes while the doors are opened for a one (1) minute duration every five (5) minutes. The front door shall be opened first, without the rear door, then on the next interval both front and rear doors shall be opened for one (1) minute. This staggering interval shall continue for the duration of the testing period.

The only requirements for the operational test in the preceding paragraph shall be that the room ambient temperature shall be maintained at 90° F, and the Air Conditioning system must continue to operate during the entire test period. The temperatures shall be monitored and recorded during this period for the informational use of the City. All test results shall be provided to the City.

TS 57.2.2 Pull-Up Test

The pull-up requirements for the heating system shall be in accordance with Section 11.1 of APTA's Recommended Practice "Transit Bus HVAC System Instrumentation and Performance Testing." With ambient temperature at -20 °F, and vehicle cold soaked at that temperature, the bus heating system shall warm the interior passenger compartment to an average temperature of 70 °F +/- 3°F within 70 minutes.

TS 57.3 Air Conditioning System

Comply _____ Do Not Comply _____

Thermo King all electric rear mounted A/C system with full hermetic AC compressor.

TS 57.4 Heater System

Comply _____ Do Not Comply _____

The bus shall have a 20 kW electric heater. The heater shall be equipped with safety devices to avoid overheating due to loss of coolant or water pump failure, and operation during conditions of low battery voltage.

The unit shall be electronically controlled with appropriate diagnostics for troubleshooting. Operation, as well as diagnostic data, shall be stored and shall be retrievable through a PC. The heater maintenance/diagnostic information shall be communicated through the appropriate protocol, SAE J1708 or J1939.

TS 57.4.1 Pre-Heat Function

The heater shall have capability of functioning in the preheat mode for the purpose of preheating the cabin. The preheat mode shall be enabled through a single-pole double-throw momentary switch. With the master run switch in the "off" position, toggling the switch to its momentary upward ("on") position shall enable the heater to operate in preheat. Once in preheat, the unit shall continue to operate and cycle until either the preheat switch is toggled to its momentary downward ("off") position, or the master run switch is turned "on," or the time elapsed exceeds 60 minutes, at which time the preheat mode will automatically be disabled.

The temperature sensor shall constantly measure the coolant temperature and cycle "on" if required

TS 57.5 Controls and Temperature Uniformity

Comply _____ Do Not Comply _____

The HVAC system excluding the operator's heater/defroster shall be centrally controlled with an advanced electronic/diagnostic control system with provisions for extracting/reading data. The system shall be compliant with J1939 Communication Protocol for receiving and broadcasting of data.

After manual selection and/or activation of climate control system operation mode, all interior climate control system requirements for the selected mode shall be attained automatically to within +/- 2°F of specified temperature control set-point. The temperature control set-point for the system shall be 70 °F.

Interior temperature distribution shall be uniform to the extent practicable to prevent hot and/or cold spots. After stabilization with doors closed, the temperatures between any two points in the passenger compartment in the same vertical plane, and 6 to 72 in. above the floor, shall not vary by more than 5°F with doors closed. The interior temperatures, measured at the same height above the floor, shall not vary more than +/- 5°F from the front to the rear, from the average temperature determined in accordance with APTA's "Recommended Instrumentation and Performance Testing for Transit Bus Air Conditioning System." Variations of greater than +/- 5° F will be allowed for limited, localized areas provided that the majority of the measured temperatures fall within the specified requirement.

The interior climate control system shall switch automatically to the ventilating mode if the refrigerant compressor or condenser fan fails.

The operator shall have full control over the defroster and operator's heater. The operator shall be able to adjust the temperature in the operator's area through air distribution and fans.

TS 57.6 Air Flow

Comply _____ Do Not Comply _____

TS 57.6.1 Passenger Area

The cooling mode of the interior climate control system shall introduce air into the bus at or near the ceiling height at a minimum rate of 25 cubic ft. per minute (cfm) per passenger based on the standard configuration bus carrying a number of passengers equal to 150 percent of the seated load. Airflow shall be evenly distributed throughout the bus, with air velocity not exceeding 100 ft. per minute on any passenger. The ventilating mode shall provide air at a minimum flow rate of 20 cfm per passenger.

Airflow may be reduced to 15 cfm per passenger (150 percent of seated load) when operating in the heating mode. The fans shall not activate until the heating element has warmed sufficiently to ensure at least 70° F air outlet temperature. The heating air outlet temperature shall not exceed 120°F under any normal operating conditions. The air shall be composed of no less than 20 percent outside air. All test results shall be provided to the City.

The climate control blower motors and fan shall be designed such that their operation complies with the interior noise level requirements.

TS 57.6.2 Operator's Area

The bus interior climate control system shall deliver at least 100 cfm of air to the operator's area when operating in the ventilating and cooling modes. Adjustable nozzles shall permit variable distribution or shutdown of the airflow. Airflow in the heating mode shall be reduced proportionally to the reduction of airflow into the passenger area. The windshield defroster unit shall meet the requirements of SAE Recommended Practice J382, "Windshield Defrosting Systems Performance Requirements," and shall have the capability of diverting heated air to the operator's feet and legs. The defroster or interior climate control system shall maintain visibility through the operator's side window.

TS 57.6.3 Operator's Compartment Requirements

A separate heating, ventilation and defroster system for the operator's area shall be provided and shall be controlled by the operator. The system shall meet the following requirements:

- The heater and defroster system shall provide heating for the operator and heated air to completely defrost and defog the windshield, operator's side window, and the front door glasses in all operating conditions. Fan(s) shall be able to draw air from the bus body interior and/or exterior through a control device and pass it through the heater core to the defroster system and over the operator's feet. A minimum capacity of 100 cfm shall be provided. The operator shall have complete control of the heat and fresh airflow for the operator's area.
- The defroster supply outlets shall be located at the lower edge of the windshield. These outlets shall be durable, unbreakable, and shall be free of sharp edges that can catch clothing during normal daily cleaning. The system shall be such that foreign objects such as coins or tickets cannot fall into the defroster air outlets. Adjustable ball vents or louvers shall be provided at the left of the operator's position to allow direction of air onto the side windows.

A ventilation system shall be provided to ensure operator comfort and shall be capable of providing fresh air in both the foot and head areas. Vents shall be controllable by the operator from the normal driving position. Decals shall be provided, indicating "operating instructions" and "open" and "closed" positions as well. When closed, vents shall be sealed to prevent the migration of water or air into the bus.

TS 57.6.4 Driver's Cooling

The requirements for operator's cooling shall be consistent with specifications noted in TS 55.3 Operator's Side Window. There shall be no dedicated evaporator for drivers cooling.

TS 57.6.5 Operator's Climate Control

The climate control system shall be designed to maintain the driver's compartment temperatures within the range specified for the passenger compartment by the bus HVAC system. A separate fan unit shall provide 100 cfm of air to the driver's area through directionally adjustable nozzles and an infinitely variable fan control, both of which shall be located above and ahead of the driver. Air from the evaporator shall be provided to the driver's area through vents located on the dash in front of the driver. In addition to the cooling system, a booster fan shall be provided in the operator's area and fully controlled by the operator.

TS 57.6.6 Heating

Sufficient heaters shall be provided with ducting to blow warm air upward through a cavity in the wall and discharge the warm air at the base of the windows. Control of the warm wall heating shall be through the main heating system electronic control.

TS 57.6.7 Controls for the Climate Control System (CCS)

The controls for the operator's compartment for heating, ventilation and cooling systems shall be integrated and shall meet the following requirements:

- The heat/defrost system fan shall be controlled by a separate switch that has an "off" position and at least two positions for speed control. All switches and controls shall preclude the possibility of clothing becoming entangled, and shields shall be provided, if required. If the fans are reviewed by the City, an "on/off" switch shall be located to the right of or near the main defroster switch. No fan, motor or other shall remain energized when the master switch is in the "off" or "night-park" position.
- A manually operated control valve shall control the coolant flow through the heater core unless an electric heater is used.
- If a cable-operated manual control valve is used, then the cable length shall be kept to a minimum to reduce cable seizing. Heater water control valves shall be "positive" type, closed or open. The method of operating remote valves shall require the concurrence of the City.

TS 57.6.8 Air Filtration

Air shall be filtered before entering the AC system and being discharged into the passenger compartment. The filter shall meet the ANSI/ASHRAE 52.1 requirement for 5 percent or better atmospheric dust spot efficiency, 50 percent weight arrestance, and a minimum dust holding capacity of 120 g /1,000 cfm cell. Air filters shall be easily removable for service and cleanable. Moisture drains from air intake opening shall be located so that they will not be subject to clogging from road dirt.

TS 57.7 Roof Ventilators

Comply _____ Do Not Comply _____

The Contractor shall provide a minimum of Two roof ventilators shall be provided in the roof of the bus, one approximately over or just forward of the front axle and the other approximately over the rear axle.

Each ventilator shall be easily opened and closed manually. When open with the bus in motion, this ventilator shall provide fresh air inside the bus. Each ventilator shall cover an opening area no less than 425 sq. in. and shall be capable of being positioned as a scoop with either the leading or trailing edge open no less than 4 in., or with all four edges raised simultaneously to a height of no less than 3½ inches. An escape hatch shall be incorporated into the roof ventilator. Roof ventilator(s) shall be sealed to prevent entry of water when closed. A bilingual (English/Spanish) decal giving operating instructions shall be affixed to the interior of the hatch and emergency instructions for opening from the exterior shall be affixed to the outside of the hatch.

TS 57.8 Maintainability

Comply _____ Do Not Comply _____

Manually controlled shut-off valves in the refrigerant lines shall allow isolation of the compressor and dehydrator filter for service. To the extent practicable, self-sealing couplings utilizing O-ring seals shall be used to break and seal the refrigerant lines during removal of major components, such as the refrigerant compressor. Shut-off valves may be provided in lieu of self-sealing couplings. The condenser shall be located to efficiently transfer heat to the atmosphere and shall not ingest air warmed above the ambient temperature by the bus mechanical equipment, or to discharge air into any other system of the bus. The location of the condenser shall preclude its obstruction by wheel splash, road dirt or debris. HVAC components located within 6 in. of floor level shall be constructed to resist damage and corrosion. High and low refrigerant pressure analog gauges to be located in the return air area and high and low refrigerant pressure readings accessed via diagnostics within HVAC HMI.

TS 58. Exterior Panels and Finishes

TS 58.1 Design

Comply _____ Do Not Comply _____

The bus shall have a clean, smooth, simple design, primarily derived from bus performance requirements and passenger service criteria. The exterior and body features, including grilles and louvers, shall be shaped to facilitate cleaning by automatic bus washers without snagging washer brushes. Water and dirt shall not be retained in or on any body feature to freeze or bleed out onto the bus after leaving the washer. The body, doors and windows shall be sealed to prevent leaking of air, dust or water under normal operating conditions and during cleaning in automatic bus washers for the service life of the bus.

Exterior panels shall be sufficiently stiff to minimize vibration, drumming or flexing while the bus is in service. When panels are lapped, the upper and forward panels shall act as a watershed. However, if entry of moisture into the interior of the vehicle is prevented by other means, then rear cap panels may be lapped otherwise. The windows, hatches and doors shall be able to be sealed. Accumulation of spray and splash generated by the bus's wheels shall be minimized on windows and mirrors. The basic bus structure shall be designed so that fatigue damage will not occur throughout the service life of the vehicle.

TS 58.2 Materials

Comply _____ Do Not Comply _____

Body materials shall be selected and the body fabricated to reduce maintenance, extend durability and provide consistency of appearance throughout the service life of the bus. Detailing shall be kept simple, and add-on devices and trim shall be minimized and integrated into the basic design.

TS 58.3 Finish, Appearance, and Color

Comply _____ Do Not Comply _____

Each bus shall be designed to ensure that the exterior holds a quality appearance during the entire service life of the bus.

The bus shall have a clean, smooth, simple design, primarily derived from bus performance requirements and passenger service criteria, the exterior and body features, including grilles and louvers, shall be shaped to allow complete and easy cleaning by automatic bus washers without snagging washer brushes. The bus shall have a "stylized" appearance.

All exterior surfaces shall be smooth and free of wrinkles and dents. Exterior surfaces to be painted shall be properly prepared as required by the paint system supplier prior to application of paint to ensure a proper bond between the basic surface and successive coats of original paint for the service life of the bus. Drilled holes and cutouts in exterior surfaces shall be made prior to cleaning, priming and painting to prevent corrosion. The bus shall be completely painted prior to installation of exterior lights, windows, mirrors and other items that are applied to the exterior of the bus. Body filler materials may be used for surface dressing, but not for repair of damaged or improperly fitted panels.

Paint shall be applied smoothly and evenly with the finished surface free of visible dirt and the following other imperfections:

- Blisters or bubbles appearing in the topcoat film
- Chips, scratches or gouges of the surface finish
- Cracks in the paint film
- Craters where paint failed to cover due to surface contamination
- Overspray
- Peeling
- Runs or sags from excessive flow and failure to adhere uniformly to the surface
- Chemical stains and water spots

- Dry patches due to incorrect mixing of paint activators
- Buffing swirls
- Orange peel

All exterior finished surfaces shall be impervious to diesel fuel, gasoline and commercial cleaning agents. Finished surfaces shall resist damage by controlled applications of commonly used graffiti-removing chemicals. Except for periodic cleaning, exterior surfaces of the bus shall be maintenance-free, permanently colored and not require refinish/repaint for the life of the bus. Durable, peel-resistant pressure sensitive appliques shall be used for any striping and coloring required.

All coatings will be tested based on OEM recommendations which will include adhesion testing, thickness tested either wet or dry mag, and orange peel threshold agreement. Undercoating will only include thickness and adhesion. Proper adhesion between the basic surface and successive coats of the original paint shall be measured using an Elcometer adhesion tester as outlined in ASTM D4541-85. Adhesion shall be a minimum 300 ft.-lbs. The bus manufacturer shall supply test samples of the exterior surface for each step of the painting process that may be subject to adhesion testing per ASTM G4541-87 and ASTM D4145-85. ASTM D4541-93 may be used for inspection testing during assembly of the vehicle.

Painted surfaces shall have a minimum 95 gloss and an orange peel rating of 7 or more on the Advanced Coating Technologies, Inc., orange peel standard panels set #APR 14941 or City accepted wave scan equipment. Paint shall last a minimum of six years with a minimum gloss of 90 as measured in ASTM E97-92, "Standard Test Method For Directional Reflectance."

Coach exteriors will be painted to the general graphic design submitted by the City. Minor variations to this general graphic design scheme may be required in order to accommodate the specific styling and construction of contractor's coaches, variations must be reviewed by City. City will supply to the contractors graphic design drawings of the front, rear, both sides and roof of the coaches that will be painted. The City's color scheme shall consist of design specifications to be provided prior to manufacture. The color scheme shall be no more than three (3) base colors plus base white and clear coat.

NOTE: Before acceptance of finished product, both interiors and exteriors of coaches shall be free of over spray, dust, dirt and any other contaminants.

The exact size, quantity and location of decals are subject to review/final acceptance by the City and will be conducted with the successful Contractor between time of award and pre-production meeting. The subject review will also include elements of subjective color coordination such as, but not limited to, exterior color approval and interior colors that have not been specifically addressed otherwise.

TS 58.4 Bus Design

Comply _____ Do Not Comply _____

The buses shall have a sleek, aerodynamic, modern, and fashionable design that is aesthetically appealing. A raised roof cap shall be designed to run the entire roof of the bus and conform to the contours of the body's sleek, aerodynamic, modern, and fashionable design of the bus. The raised roof cap shall mask the electrical, HVAC system, energy storage system (ESS), and any other roof mounted equipment of the bus. The raised roof cap shall flow seamlessly from the top of the windshield to the rear of the bus. The windows shall be hidden framed and mount flush with the exterior of the bus. All exterior panels shall have a smooth and seamless look with no visible fasteners. Exterior access doors shall be designed to be functional with a sleek and discrete look.

TS 58.5 Roof-Mounted Equipment

Comply _____ Do Not Comply _____

A non-skid, clearly marked walkway or steps shall be incorporated on the roof to provide access to equipment without damaging any system or bus paneling. Roof walkways shall be equipped with "D"

rings and safety line for technicians to tie off to and secure themselves to while performing roof mounted equipment work and inspections.

TS 58.6 Pedestrian Safety

Comply _____ Do Not Comply _____

Exterior protrusions along the side and front of the bus greater than ½ in. and within 80 in. of the ground shall have a radius no less than the amount of the protrusion. The exterior rearview mirrors, cameras and required lights and reflectors are exempt from the protrusion requirement. Grilles, doors, bumpers and other features on the sides and rear of the bus shall be designed to minimize toeholds or handholds. Exterior protrusions shall not cause a line-of-sight blockage for the operator.

TS 58.7 Repairs and Replacement

Comply _____ Do Not Comply _____

The lower side body of the bus shall be easily repairable by either applying common composite body repair techniques or by having lower side body panels that are made of impact-resistant material and easily and quickly replaceable.

TS 58.7.1 Side Body Panels

Structural elements supporting exterior body panels shall allow side body panels below the windows to be repaired in lengths not greater than 12.5 ft. The lower section of the side body panels shall be made of impact-resistant material and shall be easily and quickly replaceable or repairable.

TS 58.8 Rain Gutters

Comply _____ Do Not Comply _____

Rain gutters shall either be provided or designed as an integral part of the bus body. The rain gutters shall prevent water flowing from the roof onto the passenger doors and operator's side window and exterior mirrors. When the bus is decelerated, the gutters shall not drain onto the windshield, operator's side window or door boarding area. Cross sections of the gutters shall be adequate for proper operation. Rain gutters shall also be provided above passenger side windows. The rain gutter shall be a continuous design to prevent damming.

TS 58.9 License Plate Provisions

Comply _____ Do Not Comply _____

Provisions shall be made to mount standard-size U.S. license plates per SAE J686 on the front and rear of the bus. These provisions shall direct-mount or recess the license plates so that they can be cleaned by automatic bus-washing equipment without being caught by the brushes. The rear license plate provision shall be illuminated per SAE J587. License plates shall be mounted at the lower center or lower street side of the bus and shall not allow a toehold or handhold for unauthorized riders.

TS 58.10 Rub-Rails

Comply _____ Do Not Comply _____

Rub-rails composed of flexible, resilient material shall be provided to protect both sides of the bus body from damage caused by minor sideswipe accidents with automobiles. Rub-rails shall have vertical dimensions of no less than 2½ in. with the centerline no higher than 33 in. above the ground between the wheel wells. The rub-rails shall with stand impacts of 200 ft.-lbs. of energy from a steel-faced spherical missile no less than 9 in. in diameter and of a 500 lb. load applied anywhere along their length by a rigid plate 1 ft. in length, wider than the rub-rail, and with a ¼ in. end radii, with no visible damage to the rub-rail, retainer or supporting structure.

The rub-rail may be discontinued at doorways and wheel wells. A damaged portion of the rub-rail shall be replaceable without requiring removal or replacement of the entire rub-rail.

TS 58.11 Fender Skirts

Comply _____ Do Not Comply _____

Features to minimize water spray from the bus in wet conditions shall be included in wheel housing design. Any fender skirts shall be easily replaceable. They shall be flexible if they extend beyond the allowable body width. Wheels and tires shall be removable with the fender skirts in place.

Fender skirts shall be applied to exterior contour of wheelhouses for finished appearance and to control wheel splash. Wheel Skirts, except for the front wheels, shall be installed on all wheels. Wheel skirts shall be no less than 16 in. from ground level. The horizontal distance of wheel skirt protruding from the bus body panel must be less than 1 inch and must clear the station platform. The wheel skirts shall be finished to the graphic design of the bus exterior.

TS 58.12 Splash Aprons

Comply _____ Do Not Comply _____

Splash aprons, composed of ¼ in. minimum composition or rubberized fabric, shall be installed behind and/or in front of wheels as needed to reduce road splash and to protect under floor components. The splash aprons shall extend downward to within 6 in. off the road surface at static conditions. Apron widths shall be no less than tire widths. Splash aprons shall be bolted to the bus understructure. Splash aprons and their attachments shall be inherently weaker than the structure to which they are attached. The flexible portions of the splash aprons shall not be included in the road clearance measurements. Splash apron shall be installed as necessary to protect the wheelchair loading device from road splash. Other splash aprons shall be installed where necessary to protect bus equipment.

TS 59. Service Compartments and Access Doors

TS 59.1 Access Doors

Comply _____ Do Not Comply _____

Conventional vertically hinged doors shall be used for the engine compartment and for all auxiliary equipment compartments including doors for checking the quantity and adding to the drive system (motor and controller) coolant, power steering fluid, windshield washer fluid and transmission fluid. The upper radiator and A/C compartment door may be horizontally hinged.

An access door shall be provided in the front of the bus for the front heater core, either from the outside or inside the bus. The access door shall be designed in a way so that it can be opened or removed with the bike rack, farebox, or any other components installed. A mechanic shall not have to remove or adjust any components to gain access for repairs and/or servicing of the front heater core.

Access openings shall be sized for easy performance of tasks within the compartment including tool operating space. Access doors shall be of rugged construction and shall maintain mechanical integrity and function under normal operations throughout the service life of the bus. They shall close flush with the body surface. All doors shall be hinged at the top or on the forward edge and shall be prevented from coming loose or opening during transit service or in bus washing operations.

Doors with top hinges shall have safety props or counterbalancing with over-center or gas-filled springs stored behind the door or on the doorframe. All access doors shall be retained in the open and closed positions by props or counterbalancing with over-center or gas-filled springs. Springs and hinges shall be corrosion resistant. Latch handles shall be flush with, or recessed behind, the body contour and shall be sized to provide an adequate grip for opening.

Large access doors shall hinge up and out of the way or fold flat against the coach body and shall be easily operable by one person. These doors, when opened, shall not restrict access for servicing other components or systems. Retention devices used to hold the propulsion system compartment access doors in the open position shall be heavy duty and designed to last the service life of the coach. Access doors subject to becoming open by wind force shall be positioned such that the normal air flow

influence by the bus moving in a forward direction shall bias closing the door. Propulsion system compartment access doors shall be vented when possible to allow heat to escape.

TS 59.2 Access Door Latch/Locks

Comply _____ Do Not Comply _____

Latch handles shall be flush with, or recessed behind, the body contour and shall be sized to provide an adequate grip for opening. Access doors larger than 100 sq. in. in area shall be equipped with corrosion-resistant flush-mounted latches or locks except for coolant and fuel fill access doors. All such access door locks shall be flush mount, push to open type. All access doors that require a tool to open shall be standardized throughout the vehicle and will require a nominal 5/16 in. square male tool to open or lock.

TS 60. Bumpers

TS 60.1 Bumper Material

Comply _____ Do Not Comply _____

Bumper material shall be corrosion-resistant and withstand repeated impacts of the specified loads without sustaining damage. Visible surface shall be black. These bumper qualities shall be sustained throughout the service life of the bus.

TS 60.2 Location

Comply _____ Do Not Comply _____

Bumpers shall provide impact protection for the front and rear of the bus with the top of the bumper being 28 in., +/- 2 in., above the ground. Bumper height shall be such that when one bus is parked behind another, the bumper faces will contact each other.

TS 60.3 Front Bumper

Comply _____ Do Not Comply _____

No part of the bus, including the bumper, shall be damaged as a result of a 5 mph impact of the bus at curb weight with a fixed, flat barrier perpendicular to the bus's longitudinal centerline of the bus. The bumper shall return to its pre-impact shape within 10 minutes of the impact. The bumper shall protect the bus from damage as a result of 6.5 mph impacts at any point by the common carriage with contoured impact surface defined in Figure 2 of FMVSS 301 loaded to 4,000 lbs. parallel to the longitudinal centerline of the bus. It shall protect the bus from damage as a result of 5.5 mph impacts into the corners at a 30 deg. angle to the longitudinal centerline of the bus. The energy absorption system of the bumper shall be independent of every power system of the bus and shall not require service or maintenance in normal operation during the service life of the bus. The bumper may increase the overall bus length specified by no more than 7 inches.

TS 60.3.1 Bike Rack

Mounting provisions for integrated bike rack shall be made and include a solid-state proximity-sensing device. The sensing device shall be incorporated into the operator's indicator panel, alerting the operator of bike rack position when not in its fully stowed position. Bike rack manufacturer and model shall be provided by the City at the pre-production meeting.

TS 60.4 Rear Bumper

Comply _____ Do Not Comply _____

No part of the bus, including the bumper, shall be damaged as a result of a 2 mph impact with a fixed, flat barrier perpendicular to the longitudinal centerline of the bus. The bumper shall return to its pre-impact shape within 10 minutes of the impact. When using a yard tug with a smooth, flat plate bumper 2 ft. wide contacting the horizontal centerline of the rear bumper, the bumper shall provide protection at speeds up to 5 mph, over pavement discontinuities up to 1 in. high, and at accelerations up to 2

mph/sec. The rear bumper shall protect the bus when impacted anywhere along its width by the common carriage with contoured impact surface defined in Figure 2 of FMVSS 301 loaded to 4,000 lbs., at 4 mph parallel to or up to a 30 deg. angle to the longitudinal centerline of the bus. The rear bumper shall be shaped to preclude unauthorized riders standing on the bumper. The bumper shall be independent of all power systems of the bus and shall not require service or maintenance in normal operation during the service life of the bus. The bumper may increase the overall bus length specified by no more than 7 in.

TS 60.5 Bumper Material

Bumper material shall be corrosion-resistant and withstand repeated impacts of the specified loads without sustaining damage. These bumper qualities shall be sustained throughout the service life of the bus.

TS 61. Interior Panels and Finishes

TS 61.1 General

Comply _____ Do Not Comply _____

Materials shall be selected on the basis of maintenance, durability, appearance, safety, flammability and tactile qualities. Materials shall be strong enough to resist everyday abuse and vandalism; they shall be resistant to scratches, markings and other rigors of transit bus service, and corrosion resistant. Trim and attachment details shall be kept simple and unobtrusive. Interior trim shall be secured to avoid resonant vibrations under normal operational conditions.

Interior surfaces more than 10 in. below the lower edge of the side windows or windshield shall be shaped so that objects placed on them fall to the floor when the coach is parked on a level surface. The entire interior shall be cleanable with a hose, using a liquid soap attachment. Water and soap should not normally be sprayed directly on the instrument and switch panels. Any components and other electrical components within close proximity to these surfaces shall also be resistant to this cleaning method.

Requirements for additional anti-graffiti/vandalism treatments for interior surfaces shall be provided by the City. Internal surfaces, as possible, to be stainless steel or other resistant material.

TS 61.2 Interior Panels

Comply _____ Do Not Comply _____

Interior side trim panels shall be melamine-type material. Panels shall be easily replaceable and tamper resistant. They shall be reinforced, as necessary, to resist vandalism and other rigors of transit bus service. Individual trim panels and parts shall be interchangeable to the extent practicable. Grey carpet shall be used on top of non-corrosive material at the rear section of the bus. Untrimmed areas shall be painted and finished. All materials shall comply with the Recommended Fire Safety Practices defined in FTA Docket 90, dated October 20, 1993 and Interior panel required to meet FMVSS 302. Only stainless steel panels or materials that inherently do not permit corrosion shall be allowed on the interior of the bus unless, the Contractor obtains the City's approval in writing for a different type of material(s).

All materials, fabrics, colors, textures, painting schemes and all equipment and components relating to the interior decor of the bus shall be coordinated. Detailing shall be kept simple; add-on devices and trim should be minimized and where practical integrated into the basic design.

The interior layout shall be designed to convey a sense of spaciousness, pleasant surroundings, comfort, convenience and modern design, with a minimum of protrusions. There shall be no sharp corners, edges or gaps that could cut or trap a passenger's hands and/or fingers. The design shall avoid horizontal ledges and other 'dust catchers' and water traps.

TS 61.2.1 Operator Area Barrier

A barrier or bulkhead between the operator and the street-side front passenger seat shall be provided. The barrier shall minimize glare and reflections in the windshield directly in front of the barrier from interior lighting during night operation. Location and shape must permit full seat travel and reclining possibilities that can accommodate the shoulders of a 95th-percentile male. The partition shall have a side return and stanchion to prevent passengers from reaching the operator by standing behind the operator's seat. The lower area between the seat and panel must be accessible to the operator. The partition must be strong enough in conjunction with the entire partition assembly for mounting of such equipment as flare kits, fire extinguishers (1.2kg), microcomputer, public address amplifier, etc. Partition shall start 25mm (1") above floor. The panel should be properly attached to minimize noise and rattles.

The operator's barrier shall extend continually from the floor area to the ceiling and from the bus wall to the first stanchion immediately behind the operator to provide security to the operator and to limit passenger conversation. Upper front portion of the operator's barrier shall contain a driver's locker. An enclosed Operator storage area shall be provided with a positive latching door and key-lock UCP # 2051641; minimum approximate size: 355 mm x 355 mm x 355 mm (14" x 14" x 14").

An equipment box shall be located within the interior of the operator barrier and be accessible from the interior of the bus. Enclosure must be large enough to include separate sliding trays for the head sign and voice announcement, the radio and the on-board security camera road recorder. The equipment box must have a door, equipped with a latch, and lock (one set of keys to be provided with each bus). Exterior finish of this compartment, shall match the exterior finish of the trim panels.

Schedule and handout holder shall be mounted, at the City's decision, horizontally on the passenger side of the barrier or vertically, facing the passenger isle.

TS 61.2.2 Modesty Panels

Sturdy divider panels constructed of durable, unpainted, corrosion-resistant material complementing the interior shall be provided to act as both a physical and visual barrier for seated passengers. Modesty panels shall be immune to vandalism or be of a design incorporating inexpensive/easily replaceable sacrificial panels, firms, etc.

Modesty panels shall be located at, when applicable, front and rear sections of doorways to protect passengers on adjacent seats, and along front edge of rear upper level Design and installation of modesty panels located in front of forward-facing seats shall include a handhold/grab handle along its top edge. These dividers shall be mounted on the sidewall and shall project toward the aisle no farther than passenger knee projection in longitudinal seats or the aisle side of the transverse seats.

Modesty panels shall extend from at least the window opening of the side windows, and those forward of transverse seats shall extend downward to 1 and 1½ in. above the floor. Panels forward of longitudinal seats shall extend to below the level of the seat cushion. Dividers positioned at the doorways shall provide no less than a 2½ in. clearance between the modesty panel and a fully open, inward opening door, or the path of a deploying flip-out ramp to protect passengers from being pinched. Modesty panels installed at doorways shall be equipped with grab rails. The modesty panel and its mounting shall withstand a static force of 250 lbs. applied to a 4 x 4 in. area in the center of the panel without permanent visible deformation.

TS 61.2.3 Front End

The entire front end of the bus shall be sealed to prevent debris accumulation behind the dash and to prevent the operator's feet from kicking or fouling wiring and other equipment. The front end shall be free of protrusions that are hazardous to passengers standing or walking in front of the standee line area of the bus during rapid decelerations. Paneling across the front of the bus and any trim around the operator's compartment shall be formed metal or composite material. Formed metal dash panels shall be painted and finished. Composite dash panels shall be reinforced as necessary, vandal-resistant and

replaceable. All colored, painted and plated parts forward of the operator's barrier shall be finished with a dull matte surface that reduces glare. Any mounted equipment must have provision to support the weight of equipment.

TS 61.2.4 Rear Bulkhead

The rear bulkhead and rear interior surfaces shall be material suitable for exterior skin; painted and finished to exterior quality; or paneled with melamine-type material, composite, scratch-resistant plastic or carpeting and trimmed with stainless steel, aluminum or composite. The City reserves the right of selecting from any of the listed materials.

The rear bulkhead paneling shall be contoured to fit the ceiling, side walls and seat backs so that any litter or trash will tend to fall to the floor or seating surface when the bus is on a level surface. Any air vents in this area shall be louvered to reduce airflow noise and to reduce the probability of trash or liter being thrown or drawn through the grille. If it is necessary to remove the panel to service components located on the rear bulkhead, then the panel shall be hinged or shall be able to be easily removed and replaced by a mechanic in 5 minutes. Grilles where access to or adjustment of equipment is required shall be heavy duty and designed to minimize damage and limit unauthorized access.

TS 61.3 Headlining

Comply _____ Do Not Comply _____

Ceiling panels shall be made of durable, corrosion resistant, easily cleanable material. Headlining shall be supported to prevent buckling, drumming or flexing and shall be secured without loose edges. Headlining materials shall be treated or insulated to prevent marks due to condensation where panels are in contact with metal members. Moldings and trim strips, as required to make the edges tamperproof, shall be stainless steel, aluminum or plastic, colored to complement the ceiling material. Headlining panels covering operational equipment that is mounted above the ceiling shall be on hinges for ease of service but retained to prevent inadvertent opening.

TS 61.4 Fastening

Comply _____ Do Not Comply _____

Interior panels shall be attached so that there are no exposed unfinished or rough edges or rough surfaces exist. Fasteners shall be stainless steel and not self-tapping. Panels and fasteners shall not be easily removable by passengers. Exposed interior fasteners should be minimized, and where required shall be tamper resistant. Interior trim fasteners, where required, shall be cross-recessed head screws.

TS 61.5 Interior Access Panels and Doors

Comply _____ Do Not Comply _____

Panels and doors that appear to be an integral part of the interior shall provide access for maintenance and replacement of equipment. Access doors shall be hinged with gas props or over-center springs, where practical, to hold the doors out of the mechanic's way. Panels and locks shall prevent entry of mechanism lubricant into the bus interior. The locks shall be standardized so that only one tool (one tool to be provided with each bus) is required to open access doors on the bus. Locks shall provide a sufficient amount of tension to prevent the panel from vibrating, chattering, or raised edges and designed in a way to prevent whistling, water, debris, fumes, or drafts from the exterior. Access panels shall be designed with an overlapping lip securely mounted to the panel to prevent flooring material from curling up around the access panel. The overlapping lip of the access panel shall be 2 in. and overlap the panel and the flooring by 1 in. and shall be smooth and free of sharp edges and corners. Panels shall be sized sufficiently so that maintenance of the entire component can be performed by the technician.

TS 61.5.1 Floor Panels

Access openings in the floor shall be sealed to prevent entry of fumes and water into the bus interior. Flooring material at or around access openings shall be flush with the floor and shall be edge-bound

with stainless steel or another material that is acceptable to the City to prevent the edges from coming loose. Access openings shall be asymmetrical so that reinstalled flooring shall be properly aligned. Fasteners shall tighten flush with the floor. The number of special fastener tools required for panel and access door fasteners shall be minimized.

TS 61.6 Insulation

Comply _____ Do Not Comply _____

Any insulation material used between the inner and outer panels shall be physically retained and be sealed or self-sealing to minimize the entry and/or retention of moisture. Insulation properties shall be unimpaired by vibration, compacting or settling during the service life of the bus. Any insulation material used inside the engine compartment shall not absorb or retain oils or water and shall be designed to prevent casual damage that may occur during maintenance operations. All insulation materials shall comply with the Recommended Fire Safety Practices defined in FTA Docket 90-A, dated October 20, 1993 and/or FMVSS 302.

The combination of inner and outer panels on the sides, roof, wheel wells and ends of the bus, and any material used between these panels, shall provide a thermal insulation sufficient to meet the interior temperature requirements of these Technical Specifications. The bus body shall be thoroughly sealed so that the operator or passengers cannot feel drafts during normal operations with the passenger doors closed.

TS 61.7 Floor Covering

Comply _____ Do Not Comply _____

The floor covering shall have a non-skid walking surface that remains effective in all weather conditions and compliance with all ADA requirements. The floor covering, as well as transitions of flooring material to the main floor and to the entrance and exit area, shall be smooth and present no tripping hazards. Seams shall be sealed/welded per manufacturer's specifications. The standee line shall be at least 2 in. wide and shall extend across the bus aisle. This line shall be the same color as the outboard edge of the entrance/exit areas. Color/pattern shall be consistent throughout the floor covering. Floor covering shall be Altro Transflor meta/pewter, for aisle and under seats, or City reviewed equal. The ADA priority seating area shall incorporate an ADA symbol in the floor. Flooring in ADA space to be yellow color with black ADA symbol. Final design to be determined prior to production of the buses. The color and pattern shall be consistent throughout the floor covering.

The area of the front ramp platform as well as the floor area under and around the ramp in the vestibule area may be LineX sprayed-on polyurethane, non-skid surface. The step edge shall be LineX yellow.

Any areas on the floor that are not intended for standees, such as areas "swept" during passenger door operation, shall be clearly and permanently marked. The floor shall be easily cleaned and shall be arranged to minimize debris accumulation.

A one-piece 3/16t in. center strip shall extend from the vertical wall of the rear settee between the aisle sides of transverse seats to the standee line. If the floor is of a bi-level construction, then the center strip shall be one piece at each level. The covering between the center strip and the wheel housings may be separate pieces, but be 1/8th inch minimum thickness smooth finish to top of cove with 1 to 2 inch radius. At the rear door, however, a separate strip as wide as the door shall extend from the center strip to the outboard edge of the rear/exit area.

The floor under the seats and wheelchair locations shall be covered with smooth antiskid surface flooring material and the center strip shall be ribbed. The floor covering shall closely fit the sidewall in a fully sealed butt joint or extend to the top of the cove.

TS 62. Fare Collection

Comply _____ Do Not Comply _____

Space and structural provisions shall be made for installation of currently available fare collection devices, which shall be as far forward as practicable. Location of the fare collection device shall not restrict traffic in the vestibule, including wheelchairs if a front door loading device is used, and shall allow the operator to easily reach the farebox controls and to view the fare register. The farebox shall not restrict access to the operator area, shall not restrict operation of operator controls and shall not—either by itself or in combination with stanchions, transfer mounting, cutting and punching equipment, or route destination signs—restrict the operator's field of view per SAE Recommended Practice J1050. The location and mounting of the fare collection device shall allow use, without restriction, by passengers. The farebox location shall permit accessibility to the vault for easy manual removal or attachment of suction devices. Meters and counters on the farebox shall be readable on a daily basis. The floor under the farebox shall be reinforced as necessary to provide a sturdy mounting platform and to prevent shaking of the farebox.

Contractor shall provide fare collection installation layout to the City for approval. Transfer mounting, cutting and punching equipment shall be located in a position convenient to the operator. City will install its own farebox.

TS 63. Lighting

TS 63.1 Exterior

Comply _____ Do Not Comply _____

TS 63.1.1 General

Exterior lighting and reflectors shall comply, as applicable, with Part 393, Subpart B of the FMCSA and FMVSS 108.

All exterior lights shall be designed to prevent entry and accumulation of moisture or dust. Lights, lenses and fixtures shall be interchangeable to the extent practicable and shall be replaceable in less than five (5) minutes. Commercially available LED (Light Emitting Diode) type lights, with a lifetime warranty and last the lifetime of the bus shall be used at all exterior light locations. The entire assembly shall be specifically coated to protect the light from chemical and abrasion degradation.

Lights mounted on the propulsion system compartment doors shall be protected from the impact shock of door opening and closing. Light lenses shall be designed and located to prevent damage when running the bus through an automatic bus washer. As available, lights shall operate at nominal 24 Vdc and include internal voltage regulation. Front marker (clearance) lights along with lights located on the roof and sides of the bus shall have protective shields or be of the flush mount type to protect the lens against minor impacts.

TS 63.1.2 Headlights

Headlights shall be designed for ease of replacement. Standard OEM headlight installation shall be provided in accordance with federal regulations. Headlights shall incorporate a daytime running light feature. Headlights shall be LED/halogen, sealed beam. High and low beam shall be a separate assemblies. Standard OEM headlight installation shall be provided in accordance with FMVSS 108 and Part 393, Subpart B of the FMCSA as applicable.

TS 63.1.3 Tail Lights

Rear light clusters shall be surface mounted vertically on the rear end panels. Configuration of the light clusters shall be approved by the City prior to production of the buses. If the rear stop, tail and directional lights cannot be seen by an approaching motorist from the rear, while the propulsion system compartment door is open, a set of stop, tail and directional signal lights shall be provided in the propulsion system compartment, one on each side, and shall be visible to motorists approaching the coach from the rear when the propulsion system compartment door is in the open position.

TS 63.1.4 Brake Lights

Brake lights shall be provided in accordance with federal regulations. Bus shall include a 4 in. LED lower and 4 in. LED high mounted red brake lights provided on both sides of the rear of the bus along with two 18 in. strip center mount brake light(s) along the backside of the bus above the propulsion system compartment door. The high and center mount brake light(s) shall illuminate steadily with brake application. Brake lights shall be provided in accordance with FMVSS 108 and Part 393, Subpart B of the FMCSA as applicable. A center mounted brake light is provided.

TS 63.1.5 Turn Signal Lights

Turn-signal lights shall be provided on the front, rear, curb and street sides of the bus in accordance with federal regulations. Turn signal lights, 4 in. LED amber lights, shall be provided on both sides of the rear of the bus.

TS 63.1.6 Clearance and Marker Lights

Clearance marker lights shall be installed either recessed or surface mounted facing front, rear, and each side at center and rear. Front marker (clearance) lights along with lights located on the roof and directionals of the bus shall have protective shields or be of the flush mount type to protect the lens against minor impacts

TS 63.1.7 Curb & Door Lamps

Lamps at the front and rear passenger doorways comply with ADA requirements and activate only when the doors open. These lamps illuminate the street surface to a level of no less than 1 foot-candle for a distance of 3 ft. outward from the outboard edge of the door threshold. The lights are positioned below the lower daylight opening of the windows and are shielded to protect passengers' eyes from glare.

Aft of the rear door and forward of the rear wheel shall be a light that will illuminated while the master switch is in "NIGHT RUN" position and the right turn signal is activated. This light shall illuminate the right rear tire.

TS 63.1.8 Backup Lights/Alarm

A 4 in. LED back-up lights shall be provided on both sides of the rear of the bus. Visible and audible warnings shall inform following vehicles or pedestrians of reverse operation. Visible reverse operation warning shall conform to SAE Standard J593. A beeper alarm located in propulsion system compartment shall be actuated when transmission is placed in reverse gear. Audible reverse operation warning shall conform to SAE Recommended Practice J994 Type C or D.

TS 63.1.9 Emergency Hazard Lights

Hazard, 4 in. LED lights shall be provided on both sides of the rear of the bus and shall be visible from behind when the propulsion system service door opened.

TS 63.1.10 Service Area Lighting (Interior and Exterior)

LED lamps shall be provided in the rear ESS compartment and all other compartments where service may be required to generally illuminate the area for night emergency repairs or adjustments. These service areas shall include, but not be limited to, the rear ESS compartment, the communication box, junction/apparatus panels and passenger door operator compartments. Lighting shall be adequate to light the space of the service areas to levels needed to complete typical emergency repairs and adjustments. The service area lamps shall be suitable for the environment in which they are mounted.

Rear ESS compartment lamps shall be controlled by a switch mounted near the rear start controls. All other service area lamps shall be controlled by switches mounted on or convenient to the lamp assemblies. Power to the service area lighting shall be programmable. Power shall latch on with activation of the switch and shall be automatically discontinued (timed out) after 30 minutes to prevent

damage caused by inadvertently leaving the service area lighting switch in the "on" position after repairs are made.

TS 63.2 Interior

Comply _____ Do Not Comply _____

TS 63.2.1 General

The light source shall be located to minimize windshield glare, with distribution of the light focused primarily on the passengers' reading plane while casting sufficient light onto the advertising display. The lighting system may be designed to form part of or the entire air distribution duct.

The lens material shall be translucent polycarbonate. Lenses shall be designed to effectively "mask" the light source. Lenses shall be sealed to inhibit incursion of dust and insects yet be easily removable for service. Access panels shall be provided to allow servicing of components located behind light panels. If necessary, the entire light fixture shall be hinged.

All lens material shall be non-flammable polycarbonate in compliance with Doc 90A. Interior light sources shall be located to minimize windshield glare.

TS 63.2.2 Passenger Lighting

The LED passenger interior lighting system shall be Pretoria or reviewed equal. The interior lighting system shall provide a minimum 15 foot-candle illumination on a 1 square foot plane at an angle of 45 deg. from horizontal, center 33 inches above the floor and 24 in. in front of the seat back at each seat position. Allowable average light level for the rear bench seats shall be 7 foot-candles

The distribution of the light shall be focused primarily on the passengers' reading plane while casting sufficient light onto the advertising display. Photocell sensors detects and adjusts light level automatically relative to ambient light for passenger comfort. The lighting system shall interface with vehicle multiplex control systems supplied by various vendors through J1939 gateway with serial data input or discrete inputs to automatically adjust the brightness of each individual light fixture to improve driver's visibility out the windshield. The brightness of each individual light fixture shall be software programmable.

Lens shall be designed to effectively "mask" all individual LED's to make them invisible and there shall be no visible "hot spot" or "dark spot". Lens shall be sealed to inhibit incursion of dust and insects yet are easily removable for service. If threaded fasteners are used they must be held captive in the lens. Access panels shall be provided to allow servicing of components located behind light panels.

The light assemblies shall consist of high power 1 watt solid state LED strips in approximately fourteen (14) inch increments. LED's shall be manufactured by either Nichia or Philips or reviewed equal with expectation to maintain on average 60-70% of original brightness after 60,000 hours of operation.

The light system may be designed to form part of the entire air distribution duct with provisions for advertising in the coach interior shall be incorporated into the interior lighting fixtures.

When the master switch is in the RUN mode, the first light module on each side of the coach shall slowly fade to darkness when the front door is in the closed position and light output shall gradually illuminate to reach maximum light level when the door is opened. Solid state LED lighting shall have unlimited on-off cycles.

All interior lighting shall be turned off whenever the traction motor selector is in reverse and the propulsion system run switch is in the "on" position.

A three-position toggle switch, labeled "Interior Lights; On (at top), Off, "Normal" shall control the lights.

- "On" turns on all lights in any Master Switch position
- "Off" turns off lights except as noted in (2) and (3)
- "Normal" turns on all lights in "Night Run" and "Night Park" except as noted in (2).

- (1) The first light on each side (behind the Operator and the front door) is normally turned on only when the front door is opened, in "Night Run" and "Night Park." As soon as the door closes, these lights shall Dim/Extinguish. These lights shall be turned on when the toggle switch is in the "On" position.
- (2) To help eliminate windshield reflection on suburban roads, where street lighting is at a low level, the first light on each side, when "Night Run" or "Night Park" is selected, shall be controlled by the toggle switch; off in "Off" and on in "Normal." (These lights shall be turned on when the toggle switch is in the "On" position.) The lights shall have a programmable dimming function, programming to be discussed at pre-production meeting.
- (3) All interior lighting shall be turned off whenever the traction motor selector is in reverse and the propulsion system run switch is in the "on" position.

Failure of any light fixture or driver module shall be broadcasted via telltale light panel or dashboard display. The system will look for supply current and lighting fixture temperature to be approximately the same for all of the driver modules, and will show which module(s) seem to have a problem.

TS 63.2.3 Operator's Area Lighting

The operator's area shall have a fixed light to provide general illumination, and it shall illuminate the half of the steering wheel nearest the operator to a level of 5 to 10 foot-candles. This lighting shall be operator controlled by an adjustable switch located on the operator's control panel or other approved location. These lights shall be LED with a lifetime warranty

TS 63.2.4 Farebox Lighting

A light fixture shall be mounted in the ceiling above the farebox location. The fixture shall be capable of projecting a concentrated beam of light on the farebox. This light will automatically come on whenever the front doors are opened and the run switch is in the "night run" or "night park" position.

TS 63.2.5 Floor/Vestibules Lighting

Floor surface in the aisles shall be a minimum of 10 foot-candles, and the vestibule area a minimum of 4 foot-candles with the front doors open and a minimum of 2 foot-candles with the front doors closed. The front entrance area and curb lights shall illuminate when the front door is open and master run switch is in the "lights" positions. Rear exit area and curb lights shall illuminate when the rear door is unlocked.

TS 63.2.6 Step Lighting

Raised floor step lighting shall be provided by round LED side mounted or strip mounted in the step riser. Step lighting for the intermediate steps between the lower and upper floor levels shall be a minimum of 4 foot-candles and shall illuminate in night and night park positions. (Must be recess mounted low-profile to minimize tripping and snagging hazards for passengers and to protect accidental damage by passengers contacting light while using step).

Rear step well areas shall be lighted by LED step well lights in each step well, suitable mounted so that the entire step well and a portion of the ground area immediately outside the bus is sufficiently illuminated. These lights shall be shielded to protect passengers' eyes from glare. Step well lights shall be on with door open and off when the door is closed.

TS 63.2.7 Doorway Lighting

Lights at the front and rear passenger doorways shall comply with ADA requirements and shall activate only when the doors open. These lights shall illuminate the street surface to a level of no less than 1 foot-candle for a distance of 3 ft. outward from the outboard edge of the door threshold. The lights shall

be positioned below the lower daylight opening of the windows and shall be shielded to protect passengers' eyes from glare. Exterior step light shall be mounted away from wheel splash.

TS 63.2.8 Ramp Lighting

Exterior and interior ramp lighting shall comply with CFR Part 49, Sections 19.29 and 19.31.

TS 63.2.9 Service Area Lighting (Interior and Exterior)

LED lights shall be provided in the engine and all other compartments where service may be required to generally illuminate the area for night emergency repairs or adjustments. These service areas shall include, but not be limited to, the engine compartment, the communication box, junction/apparatus panels and passenger door operator compartments. Lighting shall be adequate to light the space of the service areas to levels needed to complete typical emergency repairs and adjustments. The service area lights shall be suitable for the environment in which they are mounted.

Engine compartment lights shall be controlled by a switch mounted near the rear start controls in the engine compartment. All other service area lights shall be controlled by switches mounted on or convenient to the light assemblies. Power to the service area lighting shall be programmable. Power shall latch on with activation of the switch and shall be automatically discontinued (timed out) after 30 minutes to prevent damage caused by inadvertently leaving the service area lighting switch in the "on" position after repairs are made. All lights, when available, shall be LED with a lifetime warranty.

TS 64. Decals, Numbering, and Signing

TS 64.1 General

Comply _____ Do Not Comply _____

Monograms, numbers and other special signing as specified by the City shall be applied to the inside and outside of the bus as required. Signs shall be durable and fade, chip, and peel resistant. They may be painted signs, decals or pressure-sensitive appliques. All decals shall be installed per the decal Supplier recommendations. All decals shall be sealed with clear, waterproof sealant around all exposed edges if required by the decal supplier. The City bus ID numbers and CA will be provided at the pre-production meeting. Signs shall be provided in compliance with the ADA requirements defined in 49 CFR Part 38, Subpart B, 38.27.

The City reserves the right of final approval upon acceptance of the prototype bus.

NOTE: A list of interior and exterior decals including size and location shall be reviewed by the City.

TS 64.2 Exterior

Comply _____ Do Not Comply _____

The exterior decal layout shall consist of the following basic items:

- Side stripe multi-color decals consisting of two colors
- Side reflective arrows
- Bike rack operation instructions
- ADA and accessibility decals
- The City logos and identification
- The City 4 digit bus ID numbers (front, rear, driver's side, street side, others)
- CA ID Number

TS 64.3 Interior

Comply _____ Do Not Comply _____

ADA priority seating signs as required and defined by 49 CFR, Part 38.27 shall be provided to identify the seats designated for passengers with disabilities.

Requirements for a public information system in accordance with 49 CFR, Part 38.35 shall be provided.

Coach Interior decal layout shall consist of the following basic items:

- Information required by Federal State and Local regulations
- International graphic symbols typical of transit buses
- The City bus ID numbers
- Driver and Passenger information typical of the proposed bus

TS 65. Electrical, Electronic and Data Communication Systems

TS 65.1 Overview

Comply _____ Do Not Comply _____

The Electrical System will consist of the vehicle battery systems and all other equipment that generate, distribute and use battery power throughout the vehicle (e.g., drive system batteries, inverters, motor drives, contactors, high voltage fuses, high voltage switches, wiring, relays, and connectors).

Electronics are those components of the electrical system made up of discrete solid-state devices such as transistors, resistors, capacitors and diodes that are part of individual vehicle systems. Electronics also include the integrated circuits that are part of microprocessors that allow individual vehicle systems to process and store data.

The data communication system consists of the bi-directional communications networks that electronic devices use to share data with other electronic devices and systems. Communication networks are essential to integrating electronic functions, both onboard the vehicle and off.

Information level systems that require vehicle information for their operations or provide information shall adhere to J1939 data standard.

Data communications systems are divided in to three levels to reflect the use of multiple data networks:

- **Drivetrain Level:** Components related to the powertrain, including the propulsion system components and anti-lock braking system (ABS), which may include traction control. At a minimum, powertrain components consisting of the propulsion system and anti-lock braking systems shall be powered by a dedicated and isolated ignition supply voltage to ensure data communication between components exists when the vehicle ignition is switched to the "on" position.
- **Information Level:** Components whose primary function is the collection, control or display of data that is not necessary to the safe drivability of the vehicle (i.e., the vehicle will continue to operate when those functions are inoperable). These components typically consist of those required for automatic vehicle location (AVL) systems, destination signs, fareboxes, passenger counters, radio systems, automated voice and signage systems, video surveillance and similar components.
- **Multiplex Level:** Electrical or electronic devices controlled through input/output signals such as discrete, analog and serial data information (i.e., on/off switch inputs, relay or relay control outputs). Multiplexing is used to control components not typically found on the drivetrain or information levels, such as lights; wheelchair lifts; doors; heating, ventilation and air conditioning (HVAC) systems (if applicable); and gateway devices.

FIGURE 7

Data Communications Systems Levels

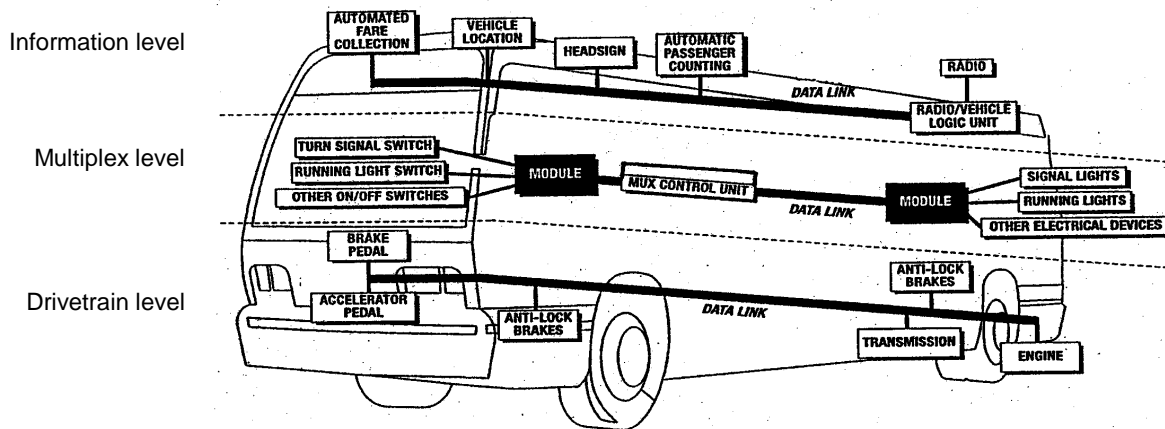

TS 65.2 Modular Design

Comply ____ Do Not Comply ____

Overall design of the electrical system, electronic and data communication systems shall be modular so that each electronic device, apparatus panel, or wiring bundle is easily separable from its interconnect with standard hand tools or by means of connectors. Each module, wiring except the body wiring harness, shall be removable and replaceable in less than 1 hour by a Specialist Mechanic.

Power plant wiring shall be an independent wiring harness. Replacement of the engine compartment wiring harness(es) shall not require pulling wires through any bulkhead or removing any terminals from the wires.

TS 65.3 Environmental and Mounting Requirements

Comply ____ Do Not Comply ____

The electrical system and its electronic components shall be capable of operating in the area of the vehicle in which they will be installed, as recommended in SAEJ1455.

Electrical and electronic equipment shall not be located in an environment that will reduce the performance or shorten the life of the component or electrical system when operating within the design operating profile. No vehicle component shall generate, or be affected by, electromagnetic interference or radio-frequency interference (EMI/RFI) that can disturb the performance of electrical/electronic equipment as defined in SAEJ1113 and UNECE Council Directive 95/54 (R10).

The mounting of the hardware shall not be used to provide the sole source ground, and all hardware shall be isolated from potential EMI/RFI, as referenced in SAE J1113. All electrical/electronic hardware mounted in the interior of the vehicle shall be in accessible to passengers and hidden from view unless intended to be viewed. The hardware shall be mounted in such a manner as to protect it from splash or spray. All electrical/electronic hardware mounted on the exterior of the vehicle that is not designed to be installed in an exposed environment shall be mounted in a sealed enclosure. All electrical/electronic hardware and its mounting shall comply with the shock and vibration requirements of SAEJ1455.

The Agency shall follow recommendations from bus manufacturers and subsystem suppliers regarding methods to prevent damage from voltage spikes generated from welding, jump starts, shorts, etc.

TS 65.3.1 Hardware Mounting

The mounting of the hardware shall not be used to provide the sole source ground, and all hardware shall be isolated from potential EMI/RFI, as referenced in SAE J1113.

All electrical/electronic hardware mounted in the interior of the vehicle shall be inaccessible to passengers and hidden from view unless intended to be viewed. The hardware shall be mounted in such a manner as to protect it from splash or spray.

All electrical/electronic hardware mounted on the exterior of the vehicle that is not designed to be installed in an exposed environment shall be mounted in a sealed enclosure.

All electrical/electronic hardware and its mounting shall comply with the shock and vibration requirements of SAE J1455.

TS 65.4 Electrical Components

Comply _____ Do Not Comply _____

All electrical components, including switches, relays, flashers, and circuit breakers, shall be heavy-duty designs and shall be of the longest lasting, commercially available type. All relays shall be internally voltage spike protected. Electrical components shall be replaceable in less than 5 minutes by a Specialist Mechanic. Sockets of plug-in components shall be polarized where required for proper function and the components shall be positively retained. Dedicated power and ground shall be provided as specified by the component or the system manufacturer.

All electric motors, except cranking motors, shall be heavy-duty brushless type, with a constant duty rating of no less than 40,000 hours. Motors shall be located for easy replacement and shall be replaceable in less than 15 minutes by a Specialist Mechanic.

TS 65.5 Electrical Compartments

Comply _____ Do Not Comply _____

All relays, controllers, flashers, circuit breakers and other electrical components shall be mounted in easily accessible electrical compartments. All compartments exposed to the outside environment shall be corrosion-resistant and sealed. The components and their functions in each electrical compartment shall be identified and their location permanently recorded on a drawing attached to the inside of the access panel or door. The drawing shall be protected from oil, grease, fuel and abrasion.

The front compartment shall be completely serviceable from the operator's seat, vestibule or from the outside. "Rear start and run" controls shall be mounted in an accessible location in the engine compartment and shall be protected from the environment.

TS 65.6 General Electronic Requirements

Comply _____ Do Not Comply _____

If an electronic component has an internal real-time clock, it shall provide its own battery backup to monitor time when battery power is disconnected, and/or it may be updated by a network component. If an electronic component has an hour-meter, it shall record accumulated service time without relying on battery backup.

All electronic component suppliers shall ensure that their equipment is self-protecting in the event of shorts in the cabling, and also in over-voltage (over 32 V DC on a 24V DC nominal voltage rating with a maximum of 50 V DC) and reverse polarity conditions. If an electronic component is required to interface with other components, it shall not require external pull-up and/or pull-down resistors. Where this is not possible, the use of a pull-up or pull-down resistor shall be limited as much as possible and easily accessible and labeled.

TS 65.6.1 Wiring and Terminals

Kinking, grounding at multiple points, stretching, and reducing the bend radius below the manufacturer's recommended minimum shall not be permitted.

TS 65.6.2 Discrete I/O (Inputs/Outputs)

All wiring to I/O devices, either at the harness level or individual wires, shall be labeled, stamped or color-coded in a fashion that allows unique identification at a spacing not exceeding 4 inches. Wiring for each I/O device shall be bundled together. If the I/O terminals are the same voltages, then jumpers may be used to connect the common nodes of each I/O terminal.

TS 65.6.3 Shielding

All wiring that requires shielding shall meet the following minimum requirements. A shield shall be generated by connecting to a ground, which is sourced from a power distribution bus bar or chassis. A shield shall be connected at one location only, typically at one end of the cable. However, certain standards or special requirements, such as SAE J1939 or RF applications, have separate shielding techniques that also shall be used as applicable.

NOTE: A shield grounded at both end forms a ground loop, which can cause intermittent control or faults.

When using shielded or coaxial cable, upon stripping of the insulation, the metallic braid shall be free from frayed strands, which can penetrate the insulation of the inner wires. To prevent the introduction of noise, the shield shall not be connected to the common side of a logic circuit.

TS 65.6.4 Communications

The data network cabling shall be selected and installed according to the selected protocol requirements. The physical layer of all network communication systems shall not be used for any purpose other than communication between the system components, unless provided for in the network specifications.

Communications networks that use power line carriers (e.g., data modulated on a 24 V power line) shall meet the most stringent applicable wiring and terminal specifications.

TS 65.6.5 Radio Frequency (RF)

RF components, such as radios, video devices, cameras, global positioning systems (GPS), etc., shall use coaxial cable to carry the signal. All RF systems require special design consideration for losses along the cable. Connectors shall be minimized, since each connector and crimp has a loss that will attribute to attenuation of the signal. Cabling should allow for the removal of antennas or attached electronics without removing the installed cable between them. If this cannot be done, then a conduit of sufficient size shall be provided for ease of attachment of antenna and cable assembly. The corresponding component vendors shall be consulted for proper application of equipment, including installation of cables.

TS 65.6.6 Audio

Cabling used for microphone level and line level signals shall be 22 AWG minimum with shielded twisted pair. Cabling used for amplifier level signals shall be 18 AWG minimum.

TS 65.7 Batteries System

Comply _____ Do Not Comply _____

Batteries shall be wired to provide both supply 12 and 24 VDC power.

Four (4) Group 31 Series deep-cycling sealed non spill able maintenance free absorbed glass mat (AGM) batteries, conforming to SAR standard J537 shall be provided. Batteries shall be Odyssey units or City reviewed equal. Each battery shall have a minimum of 1,000 cold cranking amps (CCA) at 0° F. Each unit shall be fitted with threaded stud terminals. Positive and negative terminal ends shall be different sizes. The batteries shall be designed and installed to withstand the operating environment. Each unit shall have a purchase date no more than 60 days from the date of release for the shipment to the coach manufacturer.

The 12/24 volt bus batteries shall be securely mounted on a stainless steel tray that can accommodate the size and weight of the batteries. The battery tray shall pull out easily and properly support the batteries while they are being serviced. The tray shall allow each battery cell to be easily serviced. A positive locking device shall retain the battery tray in the stowed position.

TS 65.7.1 Battery Cables

The battery terminal/cable ends and cable shall be color-coded with red for the primary positive, black for negative, and another color for any intermediate voltage cables. Cables shall be color coded differently for each voltage range. Positive and negative battery cables shall not cross each other if at all possible, shall be flexible and shall be sufficiently long to reach the batteries with the tray in the extended position without stretching or pulling on any connection and shall not lie directly on top of the batteries. Except as interrupted by the master battery switch, battery and starter wiring shall be continuous cables with connections secured by bolted terminals and shall conform to specification requirements of SAE Standard J1127–Type SGR, SGT, SGX or GXL and SAE Recommended Practice J541. Battery cables shall not be less than 4/0 gauge, shall be a premium grade welding cable 2200 strand minimum and 105° C or higher and incorporate a redundant insulation sleeve. The preferred sleeve shall be Packard Flex Guard loom. Cables shall be routed in a manner to prevent abrasion and pinch points during the routine sliding of the battery tray during battery service. Cable routing securement shall be accomplished using insulated split blocks with pinch bolts subject to the City's review, "P" clamps are not permitted. Battery cables must be of sufficient size to carry the load required by the starting motor.

TS 65.7.2 Jump Start Connection

A jump-start connector, red for 24V and blue for 12V, shall be provided, equipped with dust cap and adequately protected from moisture, dirt and debris. Connector plug to be compatible with the City's existing fleet. Location and mounting to be reviewed by the City.

TS 65.7.3 Battery Compartment

Batteries shall be easily accessible for inspection and service from only the outside of the coach. The battery compartment or enclosure shall be constructed of stainless steel and shall prevent accumulation of snow, ice and debris on top of the batteries and shall be vented and self-draining and shall be designed to remove heat in the compartment from normal battery and charging operation. It shall be accessible only from the outside of the vehicle. All components within the battery compartment, and the compartment itself, shall be protected from damage or corrosion from the electrolyte and gases emitted by the battery, and from snow, slush, salt spray, mud, etc. generated from environmental conditions outside the bus. Louvers, vents and others used for air circulation shall not allow the introduction of dust, dirt and/or road debris inside the battery compartment. The inside surface of the battery compartment's access door shall be electrically insulated, as required, to prevent the battery terminals from shorting on the door if the door is damaged in an accident or if a battery comes loose. The battery compartment temperature should not exceed battery manufacturers' specification.

The battery compartment shall be free of any component(s) that generate or produce sparks in general. No other components, devices or wirings, specifically required for battery operation, shall be located in the battery compartment or the immediate vicinity of the battery if not in an enclosed compartment. No relays, circuit breakers or others, similar in nature or functioning shall be mounted inside the battery compartment. The battery compartment door shall have a permanently mounted –non fading – plate depicting the main electrical cable routings and circuits.

The batteries shall be securely mounted on a stainless steel or equivalent tray that can accommodate the size and weight of the batteries. The battery hold-down bracket shall be constructed of a non-conductive and corrosion-resistant material (plastic or fiberglass). The battery tray, if applicable, shall pullout easily and properly support the batteries while they are being serviced. The tray shall allow each battery cell to be easily serviced. A locking device shall retain the battery tray to the stowed position.

The same fire-resistant properties must apply to the battery compartment. No sparking devices should be located within the battery box.

The vehicle shall be equipped with a 12 VDC and 24 VDC quick disconnect switch(es).

The battery compartment door shall conveniently accommodate operation of the 12 VDC and 24 VDC quick disconnect switch(es). The battery quick disconnect access door shall be identified with a decal. The decal size shall not be less than 3.5 x 5in. (8.89 x 12.7cm).

This access door shall not require any special locking devices to gain access to the switch, and it shall be accessible without removing or lifting the panel. The door shall be flush-fitting and incorporate a spring tensioner or equal to retain the door in a closed position when not in use.

TS 65.7.4 Auxiliary Electronic Power Supply

If required, gel-pack, or any form of sealed (non-venting) batteries used for auxiliary power are allowed to be mounted on the interior of the vehicle if they are contained in an enclosed, non-air tight compartment and accessible only to maintenance personnel. This compartment shall contain a warning label prohibiting the use of lead-acid batteries.

TS 65.7.5 Master Battery Switch

A single master switch shall be provided near the battery compartment for the disconnecting of all battery positives (12V & 24V) except for safety devices such as fire suppression system and other systems as specified. The location of the master battery switch shall be clearly identified on the exterior access panel, be accessible in less than 10 seconds for de-activation, and prevent corrosion from fumes and battery acid when the batteries are washed off or are in normal service. Turning the master switch "OFF", with the power plant operating, shall not damage any component of the electrical system. The master switch shall be capable of carrying and interrupting the total circuit load.

TS 65.7.6 Low-Voltage Generation and Distribution

The Propulsion System Batteries shall maintain the charge on the low voltage batteries.

The vehicle shall be equipped with a 300-AMP minimum, 24 VDC DC-DC power converter, suitably rated to handle the electrical load requirements. The high output DC amps shall be achieved at the DC-DC Power converter's designed maximum output. The unit shall be capable of supplying the entire nighttime operating electrical load of the coach while providing at least 20 percent of its current output for battery charging when the battery is fully discharged.

Power distribution shall be accomplished by means of conductive bus-bars, terminal strips, or stud-terminal blocks that are sized for the cumulative total current of connected branch circuits and for the physical securement of them. One such arrangement is to exist for each voltage potential level and ground. These points to all equipment requiring dedicated power and ground wiring to the batteries shall be accomplished by using power bus bars consisting of either a solid copper bar or heavy-duty terminal strip. One bus bar for each voltage potential, including ground, shall be located as close, electrically speaking, to the source of the potential (the battery source) as physically practical, based on recommendations of the vehicle manufacturer. Terminal stack-up is not to exceed a quantity of four (4) per each individual screw, post, or stud block. All cabling and wiring associated with an individual circuit will be sized to ensure a voltage drop figure of no more than 5% of the source voltage. This figure is to cover the total loop from source potential to source ground.

The Contractor shall provide, prior to production, an analysis reviewed by the City, demonstrating that the alternator supplied is adequate for coach operation in the service area of the City. Alternator cooling methods shall be reviewed by the City.

TS 65.7.7 Circuit Protection

All branch circuits shall be protected by current-limiting devices such as circuit breakers, fuses or solid-state devices sized to the requirements of the circuit. Circuit breakers or fuses shall be sized to a minimum of 15 percent larger than the total circuit load. The current rating for the wire used for each circuit must exceed the size of the circuit protection being used.

Electronic circuit protection for the cranking motor shall be provided to prevent engaging of the motor for more than 30 seconds at a time to prevent overheating.

The circuit breakers or fuses shall be easily accessible for authorized personnel. All manual reset circuit breakers critical to the operation of the bus shall be mounted in a location convenient to the City mechanic. Any manually resettable circuit breakers shall provide a visible indication of open circuits. The City shall consider the application of automatic reset circuit breakers on a case-by-case basis. Any manually resettable circuit breakers shall provide a visible indication of open circuits.

Fuses shall be used only where it can be demonstrated that circuit breakers are not practicable. This requirement applies to in-line fuses supplied by either the Contractor or a supplier. Fuse holders shall be constructed to be rugged and waterproof. The Contractor shall show all in-line fuses in the final harness drawings.

Electronic circuit protection for the cranking motor shall be provided to prevent engaging of the motor for more than 30 seconds at a time to prevent overheating.

TS 65.8 Grounds

Comply _____ Do Not Comply _____

The battery shall be grounded to the vehicle chassis/frame at one location only, as close to the batteries as possible. When using a chassis ground system, the chassis shall be grounded to the frame in multiple locations, evenly distributed throughout the vehicle to eliminate ground loops. No more than five ground ring/spade terminal connections shall be made per ground stud with spacing between studs ensuring conductivity and serviceability. Electronic equipment requiring an isolated ground to the battery (i.e., electronic ground) shall not be grounded through the chassis.

TS 65.9 Low Voltage/Low Current Wiring and Terminals

Comply _____ Do Not Comply _____

All power and ground wiring shall conform to specification requirements of SAE Recommended Practice J1127, J1128 and J1292. Cabling to the equipment must be sized to supply the current requirements with no greater than five (5) percent voltage drop across the length of the cable. Double insulation shall be maintained as close to the junction box, electrical compartment or terminals as possible. The requirement for double insulation shall be met by wrapping the harness with plastic electrical tape or by sheathing all wires and harnesses with non-conductive, rigid or flexible conduit.

Wiring shall be grouped, numbered and/or color-coded. Wiring harnesses shall not contain wires of different voltage classes unless all wires within the harness are insulated for the highest voltage present in the harness.

Kinking, grounding at multiple points, stretching, and exceeding minimum bend radius shall be prevented. Strain-relief fittings shall be provided at all points where wiring enters electrical compartments. Grommets or other protective material shall be installed at points where wiring penetrates metal structures outside of electrical enclosures. Wiring supports shall be protective and non-conductive at areas of wire contact and shall not be damaged by heat, water, solvents or chafing.

To the extent practicable, wiring shall not be located in environmentally exposed locations under the vehicle. Wiring and electrical equipment necessarily located under the vehicle shall be insulated from water, heat, corrosion and mechanical damage. Where feasible, front-to-rear electrical harnesses should be installed above the window line of the vehicle.

All wiring harnesses over 5ft. long and containing at least five wires shall include 10 percent (minimum one wire) excess wires for spares. This requirement for spare wires does not apply to data links and communication cables. Wiring harness length shall allow end terminals to be replaced twice without pulling, stretching or replacing the wire.

All cable connectors shall be locking type, keyed and sealed, unless enclosed in watertight cabinets or vehicle interior. Pins shall be removable, crimp contact type, of the correct size and rating for the wire being terminated. Connector pins/terminals shall be crimped to the wiring according to the connector manufacturer's recommendations for techniques and tools. Unused pin positions shall be sealed with sealing plugs. Adjacent connectors shall use different insert or dentations to prevent incorrect connections.

Terminals shall be crimped, corrosion-resistant and full ring type or interlocking lugs with insulating ferrules. Insulation clearance between ferrule and wire insulation shall ensure that wires have a minimum of "visible clearance" and a maximum clearance of two times the conduct or diameter or 1/16 in., whichever is less. When using shielded or coaxial cable, upon stripping of the insulation, the metallic braid shall be free from frayed strands that can penetrate the insulation of the inner wires. When using pressure type screw terminal strips, only stranded wire shall be used. Cables shall be adequately mounted such that is the lug fails, the cable shall remain in place.

Ultra-sonic and T-splices may be used with 8 AWG or smaller wire. When a T-splice is used, it shall meet these additional requirements:

- It shall include a mechanical clamp in addition to solder on the splice.
- The wire shall support no mechanical load in the area of the splice.
- The wire shall be supported to prevent flexing.

All splicing shall be staggered in the harness so that no two splices are positioned in the same location within the harness.

Wiring located in the engine compartment shall be routed away from high-heat sources or shielded and/or insulated from temperatures exceeding the wiring and connector operating requirements.

The instrument panel and wiring shall be easily accessible for service from the operator's seat or top of the panel. The instrument panel shall be separately removable and replaceable without damaging the instrument panel or gauges. Wiring shall have sufficient length and be routed to permit service without stretching or chafing the wires.

TS 66. Multiplexing

TS 66.1 General

Comply _____ Do Not Comply _____

The primary purpose of the multiplexing system is control of components necessary to operate the vehicle. This is accomplished by processing information from input devices and controlling output devices through the use of an internal logic program.

Versatility and future expansion shall be provided for by expandable system architecture. The multiplex system shall be capable of accepting new inputs and outputs through the addition of new modules and/or the utilization of existing spare inputs and outputs. All like components in the multiplex system shall be modular and interchangeable with self-diagnostic capabilities. The modules shall be easily accessible for troubleshooting electrical failures and performing system maintenance. Each module shall be shielded to prevent interference by EMI and RFI; and shall use LEDs to indicate circuit integrity, assist in rapid circuit diagnostics, and verify the load and wiring integrity. In conjunction with relays if necessary, each circuit shall be capable of providing a current load of up to 10 Amperes. Multiplex input/output modules and internal controls shall be a solid-state devices to provide extended service life and individual circuit protection. Wiring for data bus and node module power shall consist of three, 22 gauge or larger, UL approved, shielded twisted pairs. Ten percent of the total number of

inputs and outputs, or at least one each for each voltage type utilized (0 V, 12 V, 24 V) at each module location shall be designated as spares.

Protection to each individual circuit shall be provided. An automatic test system, integral to the multiplexing, shall be provided. The system shall be hosted on an IB-compatible personal computer as well as a hand held field diagnostic unit capable of reading the network data, control function and address data, or function code. The mechanic shall use either unit to check the bus wire function.

TS 66.2 System Configuration

Comply _____ Do Not Comply _____

Multiplexing may either be distributed or centralized. A distributed system shall process information on multiple control modules within the network. A centralized system shall process the information on a single control module. Either system shall consist of several modules connected to form a control network.

TS 66.2.1 I/O Signals

The input/output for the multiplex system may contain four types of electrical signals: discrete, modulating, analog or serial data.

Discrete signals shall reflect the on/off status of switches, levers, limit switches, lights, etc. Analog signals shall reflect numerical data as represented by a voltage signal (0–12 V, 10–24 V, etc.) or current signal (4–20 mA). Both types of analog signals shall represent the status of variable devices such as, but not limited to, rheostats, potentiometers, temperature probes, etc. Serial data signals shall reflect ASCII or alphanumeric data used in the communication between other on-board components.

TS 67. Data Communications

TS 67.1 General

Comply _____ Do Not Comply _____

All data communication networks shall be either in accordance with a nationally recognized interface standard, such as those published by SAE, IEEE or ISO, or shall be published to the City with the following minimum information:

- Protocol requirements for all timing issues (bit, byte, packet, inter-packet timing, idle line timing, etc.) packet sizes, error checking and transport (bulk transfer of data to/from the device).
- Data definition requirements that ensure access to diagnostic information and performance characteristics.
- The capability and procedures for uploading new application or configuration data.
- Access to revision level of data, application software and firmware.
- The capability and procedures for uploading new firmware or application software.
- Evidence that applicable data shall be broadcast to the network in an efficient manner such that the overall network integrity is not compromised.

Any electronic vehicle components used on a network shall be conformance tested to the corresponding network standard.

The vehicle shall be designed with a fully integrated diagnostic system where the master vehicle controller monitors and records the fault status from all systems on the main PCAN network as well as fault status from the multiplex devices. This shall include subsystems such as the powertrain controller, cooling system, ABS system, HVAC system, battery management system and other power devices. This diagnostic system shall also include the detection of loss of communication of all individual devices on the PCAN and MCAN network.

All faults shall be recorded, time stamped, odometer stamped and assigned a priority level based on the severity of the fault. A diagnostic tool shall also serve as a troubleshooting guide to aid in quick resolution of individual faults.

The following information shall be displayed when using the instrument cluster and diagnostic tool:

- Fault status (active or previously recorded and inactive)
- Identifying number (SPN and FMI according to J1939)
- General description of part faulted (SPN description)
- Type of fault (FMI description; i.e. value to high, to low, data erratic, loss of communication)
- Mux input or output pin where fault was detected or system where fault was originated
- Time, date and odometer reading at time of fault

A vehicle data logger must be provided to monitor J1939 communications system. It shall provide:

- Continuous monitoring and recording of the PCAN J1939 data bus.
- Software that can generate structured reports using the gathered data.
- Software to create tools for incident definition, data import/export, analysis and presentation.
- Software for recording of user selected J1939 fault codes.

TS 67.2 Drivetrain Level

Comply _____ Do Not Comply _____

Drivetrain components, consisting of the engine, transmission, retarder, anti-lock braking system and all other related components, shall be integrated and communicate fully with respect to vehicle operation with data using SAE Recommended Communications Protocols such as J1939 and/or J1708/J1587 with forward and backward compatibilities or other open protocols. At a minimum, drivetrain components consisting of the engine, transmission, retarder ASR, and anti-lock braking systems shall be powered by a dedicated and isolated ignition supply voltage to ensure data communication among components exists when the vehicle ignition is switched to the "on" position.

TS 67.2.1 Diagnostics, Fault Detection and Data Access

Drivetrain performance, maintenance and diagnostic data, and other electronic messages shall be formatted and transmitted on the communications networks.

The drivetrain level shall have the ability to record abnormal events in memory and provide diagnostic codes and other information to service personnel. At a minimum, this network level shall provide live/fail status, current hardware serial number, software/data revisions and uninterrupted timing functions.

TS 67.2.2 Programmability (Software)

The drivetrain level components shall be programmable by the City with limitations as specified by the subsystem Supplier.

TS 67.3 Multiplex Level

Comply _____ Do Not Comply _____

TS 67.3.1 Data Access

At a minimum, information shall be made available via a communication port on the multiplex system. The location of the communication port shall be easily accessible. A hardware gateway and/or wireless communications system are options if requested by the City. The communication port(s) shall be located as specified by the City.

TS 67.3.2 Diagnostics and Fault Detection

The multiplex system shall have a proven method of determining its status (system health and input/output status) and detecting either active (online) or inactive (offline) faults through the use of on-board visual/audible indicators.

In addition to the indicators, the system shall employ an advanced diagnostic and fault detection system, which shall be accessible via either a personal computer or a handheld unit. Either unit shall have the ability to check logic function. The diagnostic data can be incorporated into the information level network or the central data access system.

A mock-up board, where key components of the multiplexing system are replicated on a functional model, shall be provided as a tool for diagnostic, design verification and training purposes. If required, the mock-up board should be priced separately in the Pricing Schedule.

TS 67.3.3 Programmability (Software)

The multiplex system shall have security provisions to protect its software from unwanted changes. This shall be achieved through any or all of the following procedures:

- Password protection
- Limited distribution of the configuration software
- Limited access to the programming tools required to change the software
- Hardware protection that prevents undesired changes to the software

Provisions for programming the multiplex system shall be possible through a PC or laptop. The multiplex system shall have proper revision control to ensure that the hardware and software are identical on each vehicle equipped with the system. Revision control shall be provided by all of the following:

- Hardware component identification where labels are included on all multiplex hardware to identify components
- Hardware series identification where all multiplex hardware displays the current hardware serial number and firmware revision employed by the module
- Software revision identification where all copies of the software in-service display the most recent revision number
- A method of determining which version of the software is currently in use in the multiplex system

Revision control labels shall be physically located near the programming port.

TS 67.4 Diagnostic Ports

Comply _____ Do Not Comply _____

Diagnostic test ports, when provided and available for each electronic control subsystem including engine, transmission and ABS, shall be provided in the driver's area, engine compartment control panel, and ITS enclosure, subject to City approval.

Automated Light and Signal Test:

- An automated "pre-trip" test system shall enable drivers to perform a "walk-around" function check of all exterior lights and signals.
- The system shall self-cancel after three (3) minutes.
- A dedicated dash mounted switch or combination of existing switches (such as depressing both turn signal switches) shall activate the test.

TS 67.5 Electronic Noise Control

Comply _____ Do Not Comply _____

Electrical and electronic subsystems and components on all buses shall not emit electromagnetic radiation that will interfere with on-board systems, components or equipment, telephone service, radio or TV reception, or violate regulations of the Federal Communications Commission.

Electrical and electronic subsystems on the coaches shall not be affected by external sources of RFI/EMI. This includes, but is not limited to, radio and TV transmission, portable electronic devices

including computers in the vicinity of or onboard the buses, AC or DC power lines and RFI/EMI emissions from other vehicles.

TS 68. Make Ready Provisions, Intelligent Transportation Systems (ITS)

Comply _____ Do Not Comply _____

Unless otherwise specified, the Contractor shall provide certain "Make Ready Provisions" that will accommodate post-delivery installation ITS equipment. Make ready provisions may include installing specified equipment (such as antennas, passenger counter sensors, and wiring harnesses), and providing power supplies, conduit, structural mounting provisions, and space for ITS equipment. Make Ready Provisions shall be reviewed by the City prior to start of production, subject to City approval. The Contractor shall perform the installation and testing to the ITS equipment and shall coordinate directly with the City's equipment suppliers on the interfaces for the equipment and testing support. The Contractor shall be responsible for delivering a complete and tested bus with associated ITS and other communications equipment. The City, at its discretion, may witness integrated factory testing, otherwise verification will be performed during the acceptance testing.

The following ITS system equipment/devices may be included, but is not limited to:

- Farebox
- GPS
- AVL
- APC
- IVLU
- Wireless LAN Modem
- WIFI

An equipment enclosure shall be provided to accommodate installation of the City's ITS equipment. This equipment will require a clear space above the slide out tray of a minimum of 11 in. high, 27 in. wide and 21 in. deep. Unless otherwise specified, additional ITS equipment provided and installed by the Contractor may also be installed within the ITS enclosure. The preferred location for the enclosure is located in the passenger compartment as far from the engine as possible. The ITS enclosure shall be as large as practical to facilitate future expansion of ITS equipment, and shall be splash-proof and actively ventilated. The ITS enclosure shall include a minimum of three modular slide out trays which are easily removable and can be repositioned to accommodate changes in equipment position as needed. Slide out trays shall incorporate heavy duty slide or roller mechanism to support a minimum of 150 lbs. of loading each and shall be able to withstand the normal shock and vibration, (under full load) experienced in City revenue service, without damage to the slide or roller mechanisms. Slide out trays shall have locking mechanisms that hold the tray in both the open and closed positions.

Service light(s) that illuminate each tray with suitable switch shall be provided within the enclosure, subject to City approval. A system of preinstalled "ITS conduits" will be provided to assist with future installation and replacement of wiring and cabling associated with the City's ITS equipment. Make Ready Provisions, Intelligent Transportation System (ITS). ITS conduits, in conjunction with existing bus wire ways, will be required where future City installation and replacement of cabling is not practical such as removing interior paneling or dash assembly. In general, conduits exposed to the interior of the bus shall be water tight and have a minimum 3/4 in. inside diameter and be routed to permit pulling cables, less connectors, through the conduits using a preinstalled "pull wire". Conduits will be terminated at the ITS enclosure using suitable reusable water tight fittings. Conduit installation shall follow best commercial practices with regard to drip loops and routing to avoid moisture problems.

TS 68.1 Automatic Vehicle Annunciation/Automatic Vehicle Location

Comply _____ Do Not Comply _____

Complete system provided by the OEM.

TABLE 6
 AVA/AVL System

	Requirement
AVA/AVL Supplier	[Insert requirement]
Controller Unit/module	[Insert requirement]
Driver Display/HMI	[Insert requirement]
cable types	[Insert requirement]
Antenna #1	[Insert requirement]
Antenna #2	[Insert requirement]
Antenna #3	[Insert requirement]
Mic	[Insert requirement (Y/N?)]
Interior LED Sign	[Insert requirement (Y/N?)]
Does AVA/AVL system include two-way radio?	[Insert requirement (Y/N?)]
[Insert other requirements]	[Insert requirement]
[Insert other requirements]	[Insert requirement]
[Insert other requirements]	[Insert requirement]
[Insert other requirements]	[Insert requirement]

TS 69. Signage and Communication

TS 69.1 Destination Signs

Comply _____ Do Not Comply _____

A destination sign system shall be furnished on the front, right side near the front door, and route sign on the rear of the vehicle. The sign located near the front door shall not block the operator's critical horizontal line of sight. Display areas of destination signs shall be clearly visible in direct sunlight and/or at night. Parts shall be commercially available. All signs shall be controlled via a single human-machine interface (HMI). In the absence of a single mobile data terminal (MDT), the HMI shall be conveniently located for the bus operator within reach of the seated operator.

The sign system shall be Hanover or City reviewed equal destination sign communication protocol - J1708. (Note: MUST have J1708) Color front, amber side and rear, or reviewed equal, consisting of a front, side, rear, and Operator Display Keyboard (ODK). to include the following signs:

- Front, 17 x 160
- Side, 8 x 96
- Rear 16 x 48

Sign system control shall be capable of accepting logon and route entry via interface to Xerox Communication interface and manual

The destination sign compartments shall be designed to meet the following minimum requirements:

- Prevent condensation and entry of moisture and dirt.
- Prevent fogging of both compartment window and glazing on unit itself.
- Access shall be provided to allow cleaning of inside compartment window and unit glazing.
- Front window shall have an exterior display area of no less than 8.5 in. high by 56 in. wide.

TS 69.1.1 Text Messaging Sign

Two interior next stop sign display signs shall be supplied, compatible with the auxiliary communication system ACS radio system. One sign shall be located so as to be visible to the seated operator and seated passengers in the front section of the bus. The second sign shall be located aft of the articulation joint so as to be visible to seated passengers in the rear section of the bus. The signs shall be capable of displaying the next stop request sign function in addition to displaying the scrolled next stop announcement. The text message sign manufacturer shall be selected and approved by the City.

The interior stop request / next stop announcement displays shall:

- Be a single line 16 character, 27"x2.125"x6.125", red LED display with clear 20/20 visibility at a minimum of 90 ft. and with a +/- 75 deg. view angle.
- Power requirements for the display shall not exceed 30W and shall be capable of operating on a voltage between + 10 Vdc and + 30 Vdc.
- The display shall be addressable through the City radio system and have a SAE J1708/1587 compliant RS-485 serial communication interface.
- The system shall be capable of operating with temperatures between 0 and 40 deg. C., and at relative humidity between 10 and 90 %.
- The unit shall withstand temperatures between -40 and +70 deg. C. without damage or deterioration.
Have power supplied by the same source as the radio equipment over a minimum of 18 AWG two-conductor fused power cable with a twisted shielded cable pair for connecting the J1708 control signals.
- Have the power cable and signal lines share a single split loom jacket. The connections are made with ring terminal lugs. There shall be four: two signal connections and two power connections.

TS 69.1.2 Passenger Information and Advertising

TS 70.1.2.1 Interior Displays

Provisions shall be made on the rear of the operator's barrier or equipment box located on the wheel well for a frame to retain information such as routes and schedules.

Advertising media 11 in. high and 0.09 in. thick shall be retained near the juncture of the bus ceiling and sidewall. The retainers may be concave and shall support the media without adhesives. The media shall be illuminated by the interior light system.

TS 70.1.2.2 Exterior Displays

Provisions shall be made to integrate advertising into the exterior design of the bus. Advertising media, frames or supporting structures shall not detract from the readability of destination signs and signal lights, and shall not compromise passenger visibility. Advertising provisions shall not cause pedestrian hazards or foul automatic bus washing equipment, and shall not cover or interfere with doors, air passages, vehicle fittings or in any other manner restrict the operation or serviceability of the bus.

TS 69.2 Passenger Stop Request/Exit Signal

Comply _____ Do Not Comply _____

TS 69.2.1 General

A passenger "Stop Requested" signal system that complies with applicable ADA requirements defined in 49 CFR, Part 38.37, shall be provided. The system shall consist of a heavy-duty pull cable, chime and interior sign message. The pull cable shall be located the full length of the bus on the sidewalls at the level where the transom is located. If no transom window is required, then the height of the pull cable shall approximate this transom level and shall be no greater than 63 in. as measured from the floor surface of the bus. It shall be easily accessible to all passengers, seated or standing. Pull cable(s) shall activate one or more solid state or magnetic proximity switches. At each wheelchair passenger

position and at priority seating positions, additional provisions shall be included to allow a passenger in a mobility aid to easily activate the "Stop Requested" signal.

An auxiliary passenger "Stop Requested" signal shall be installed at the rear door to provide passengers standing in the rear door/exit area a convenient means of activating the signal system. The signal shall be a heavy-duty push button type located in the rear door vicinity. Button shall be clearly identified as "Passenger Signal."

All "Stop Request" signals locations and types shall be reviewed by the City prior to bus manufacturing.

TS 69.2.2 Chime

A single "stop requested" chime shall sound when the system is first activated. A double chime shall sound anytime the system is activated from wheelchair passenger areas. With a voice annunciation system activated, an announcement of a stop request or lift request or both will occur. Exit signals located in the wheelchair passenger area shall be no higher than 4 ft. above the floor. Instructions shall be provided to clearly indicate function and operation of these signals. The operator shall be able to deactivate the signal system from the operator's area.

TS 69.3 Public Address System

Comply _____ Do Not Comply _____

Contractor shall provide and install all necessary equipment for the public address system. A public address system shall be provided on each bus for facilitating radio system and driver-originated announcements to passengers. The Public Address system shall include an advanced technology system that can reduce background noise. It shall provide a highly sensitive unidirectional microphone element. The system shall be muted when not in use. The microphone shall be vandal resistant, mounted on a heavy-duty, flexible gooseneck, which is secured with tamper-proof fasteners and will allow the operator to comfortably speak into it without using his hands. A provision shall be provided to secure the microphone in a stored position when not in use.

TS 69.3.1 Microphone

An input jack shall be provided in the operator's area for a hand held microphone. 1 P.A. Amplifier located above the driver to the left. Controls shall be accessible to the seated driver. The driver's area shall be furnished with a single 30" gooseneck microphone.

TS 69.3.2 Speakers

A sufficient number of interior loudspeakers, minimum of 6, shall be provided, semi-flush mounted, on alternate sides of the bus passenger compartment, installed with proper phasing. They shall be installed at locations in the ceiling of the vehicle with all connecting wires available in a wire loom for easy replacement and protection. Total impedance seen at the input connecting end shall be 8 Ohms. Speakers wired in series shall incorporate shunt resistors to prevent an open circuit in the event of a speaker failure. Mounting shall be accomplished with riv-nuts and machine screws. One exterior loud speaker shall be installed in the curbside skirt panel aft of the front wheel, protected from the elements and road debris.

The speaker cable shall terminate at the instrument panel area on the curb side with a minimum of 3 feet of extra speaker cable. An end connector shall be supplied so a lead can be connected from the radio control head in order to make announcements directly from the transit control center to passengers through the PA system.

TS 69.3.3 Switch

The microphone shall be activated by a momentary foot control switch which will over-ride the auto-annunciation when activated.

TS 69.4 Automatic Passenger Counter (APC)

Comply _____ Do Not Comply _____

A Dilax infrared APC system shall be installed. City to provide details of APC system, including installation locations.

TS 69.5 Radio Handset and Control System

Comply _____ Do Not Comply _____

TS 69.5.1 Operator's Speaker

Each bus shall have a recessed speaker in the ceiling panel above the operator. This speaker shall be the same component used for the speakers in the passenger compartment. It shall have 8 Ohms of impedance.

TS 69.5.2 Handset

Contractor will install a handset for operator use.

TS 69.5.3 Operator Display Unit (DDU)

Contractor shall install an operator display unit as close to the operator's instrument panel as possible.

TS 69.5.4 Emergency Alarm

Contractor shall install an emergency alarm that is accessible to the driver but hidden from view.

TS 70. Camera Surveillance System

Comply _____ Do Not Comply _____

Provide all wiring and mounting locations for a multi-camera surveillance system for the later provision of and installation of cameras, recorder, microphone, etc. The camera system cable to be installed, the locations for pre-wiring and the quantity shall be provided by the City at pre-production meeting. All wiring for the surveillance system shall be soldered and heat shrunk where applicable. All cameras installed on City buses shall be color video surveillance cameras suitable for the transit bus environments. Full installation for a multi-camera surveillance system, including the installation of cameras, recorder, microphone, etc. per SafetyVision specifications and shall be provided as part of the base price. SafetyVision, Table 7, is currently the City's standard surveillance system.

TABLE 7
 Surveillance System

	Camera Supplier
Camera Supplier	SafetyVision
DVR Model	[Insert Requirement]
DVR Hard Drive Size	[Insert Requirement]
Camera System Cable Type	[Insert Requirement]
Event Marker Button	[Insert requirement (Y/N?)]
Impact Sensor/Accelerometer	[Insert requirement(Y/N?)]
Discrete Mic.	[Insert requirement(Y/N?)]

TS 70.1 Camera Locations

Comply _____ Do Not Comply _____

The Digital Video surveillance system is to be provided by SafetyVision. Cameras shall provide a clear, stable, high quality color picture with the correct exposure, minimal smearing and distortion under all

lighting conditions within the vehicle. Each camera shall be capable of recording sound through a built-in microphone.

- Exact mounting locations for video cameras shall be the responsibility of the Contractor after concurrence with the City. When the cameras are aimed properly, the lens shall be locked in place by mechanical fasteners (glues or chemicals shall not be used), and shall not go out of adjustment due to vibration.
- Video cameras shall be designed and installed to achieve optimum coverage of the complete transit vehicle. The cameras shall be strategically located to record as much of the interior and exterior of the vehicle as possible, but must include the operator's area, fare collection, and all seats and windows.

A minimum of seven (7) cameras shall be mounted in the interior of each vehicle and two (2) additional cameras mounted on the exterior for a total of nine.

- (1.) The first camera (camera #1) shall be mounted opposite the front entrance door street side and shall be suitable to cover the interior front of the vehicle including the front door.
- (2.) The second camera (camera #2) shall be mounted right of center of the windshield, looking directly out the front windshield, and shall be a forward-facing camera.
- (3.) The third camera (camera #3) shall be mounted in a suitable location to cover the fare collection area, driver's area, and the equipment cabinet area.
- (4.) The fourth camera (camera #4) shall be mounted aft of the front entrance door curbside, looking aft, and shall have a view suitable to cover the front-to-mid area of the vehicle.
- (5.) The fifth camera (camera #5) shall be mounted center forward of the rear exit/entry door, looking aft, and shall have a view suitable to cover mid-to-back area of the vehicle.
- (6.) The sixth camera (camera #6) shall be mounted opposite the rear exit/entry door, looking directly at the exit/entry door, and shall have a view suitable to cover the exit/entry door and the area just outside the door when door is in the opened position.
- (7.) The seventh camera (camera #7) shall be mounted center aft of the rear exit/entry door, looking forward, and shall have a view suitable to cover mid-to-front area of the vehicle.
- (8.) The eighth camera (camera #8) shall be mounted on the front exterior of the vehicle as far forward and upward as possible to be able to cover from the driver's side window looking aft.
- (9.) The ninth camera (camera #9) shall be mounted front exterior of the vehicle as far forward and upward as possible to be able to cover from the entry door looking aft.

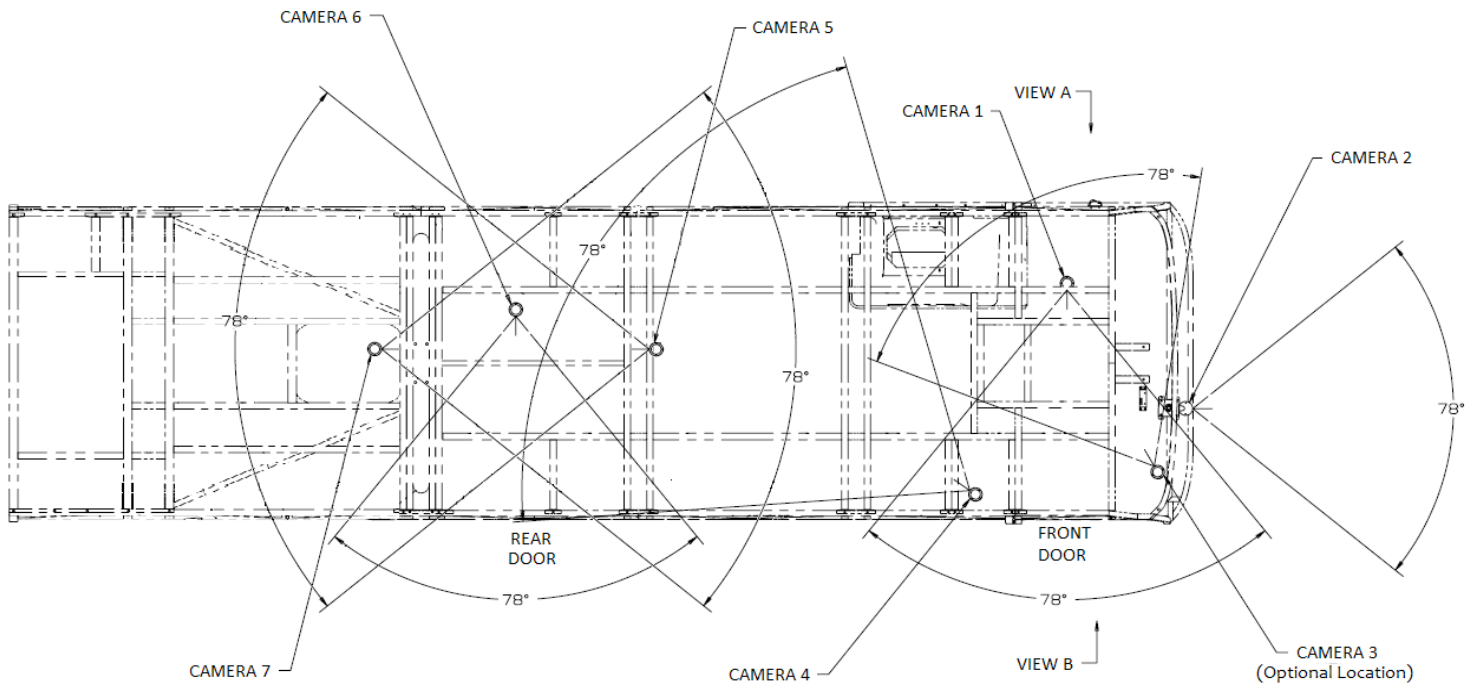

TOP VIEW
CAMERA PROJECTED ANGLE

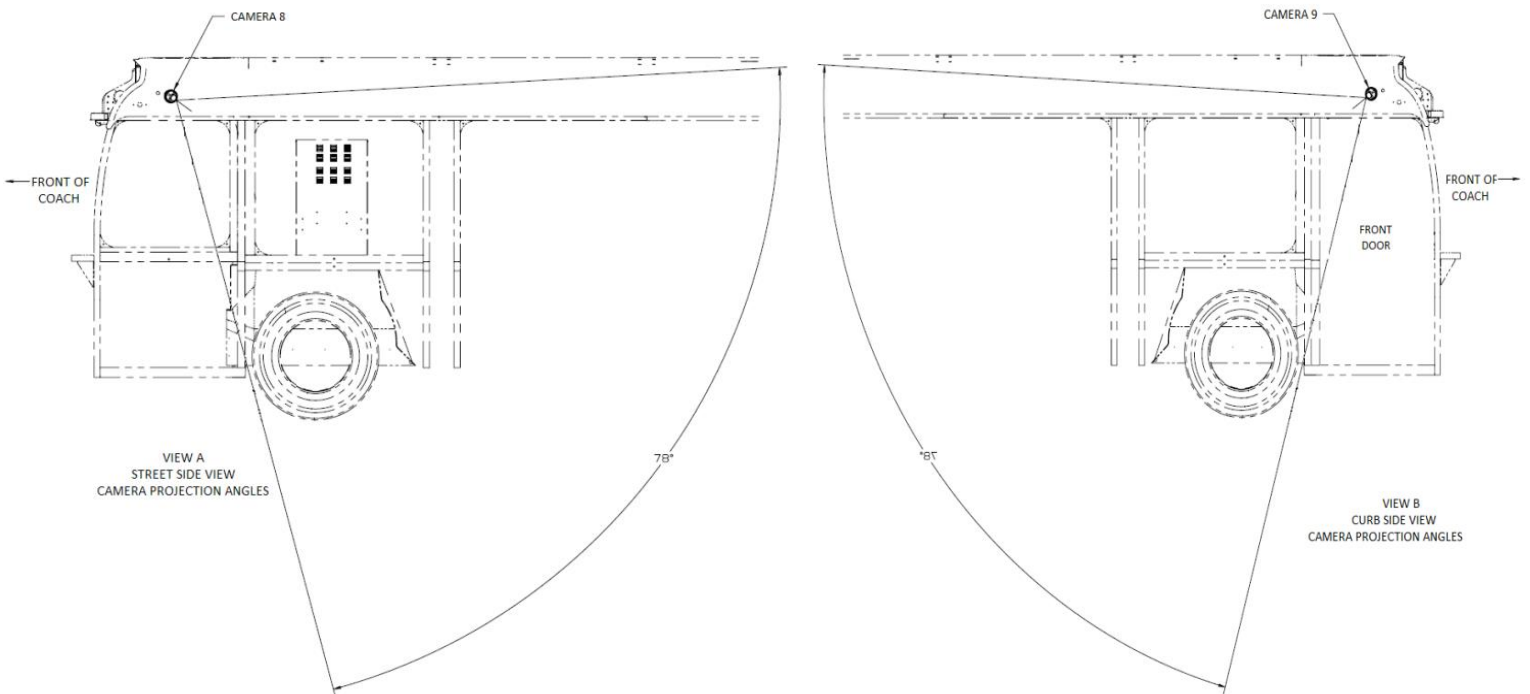

Video cameras shall be IP, high resolution 1/2.7 Progressive CMOS Dome or Wedge type. The cameras shall have a signal-to-noise ratio better than 70 db and must utilize PoE.

The video cameras must operate on Power-over-Ethernet (PoE). All cables and connectors to and from cameras, NVR and other equipment shall conform to SAE Standards.

The video cameras shall provide a useable picture at a minimum of 1.0 Lux scene illumination and must support a maximum of 1080R resolution.

TS 70.2 Camera Enclosures

Comply _____ Do Not Comply _____

The cameras shall be self-enclosed Wedge or Dome type. The enclosure shall be low profile and mounted so as to not obstruct passenger flow. Mounting of the camera and/or enclosures shall not interfere with the customer sitting or standing area, customer traffic, vehicle operator and shall not create a safety hazard condition. The camera enclosure shall be made of impact-resistant non-toxic material. Exterior camera enclosures shall be vandal resistant, shock-resistant, dust-resistant and water resistant to the IP67 standard.

TS 70.3 Network Video Recorder (NVR)

Comply _____ Do Not Comply _____

A dash mounted LCD driver interface status module (with event button) shall be installed to allow the operator to overwrite protect, and manually mark location of video for easy searching and identification.

The system shall be installed according to industry standards meeting SAE recommended practices. All cables, wiring, interconnections, switches, and circuit breakers/fuses shall be heavy-duty and specifically designed for their purposes and automotive application. The selected wire sizes and insulation shall meet the current carrying capability, voltage drop, mechanical strength, and temperature and flexibility requirements. Video and audio wires selected shall be gauged to minimize signal loss.

The NVR must have the capability for connecting at least six additional inputs for monitoring door openings, turn signal activation, braking, wheel chair extension and other transit related signals.

TS 71. Event Data Recorders (EDR)

Comply _____ Do Not Comply _____

EDRs shall be installed on the bus, one at the front and the other at the rear. These units are to be installed as low as possible. The EDRs shall be able to communicate over the J1939 CAN line and shall each be equipped with three-axis accelerometers. Settings are to be finalized with the City during pre-production. EDRs shall broadcast via the J1939 data communication link severe impact events to the vehicle monitoring system and also trigger an event in the camera system. The EDR shall also tag an event from a signal received over the J1939 CAN line from the silent alarm switch signal and the camera event button and in turn broadcast these events to the vehicle monitoring system. The EDR shall also record the following operational data: headlights on or off, turn signals and hazard lights on or off, ignition on or off, low air pressure warning, whether moving in forward or reverse or idling, and whether parking brake is on or off.

TS 71.1 Emergency Alarm

Comply _____ Do Not Comply _____

Contractor shall install an emergency alarm that is accessible to the operator but hidden from view.

SECTION 7: WARRANTY REQUIREMENTS

CITY OF FRESNO SPECIFICATIONS

PRODUCT PURCHASE CONTRACT FOR:
Two (2) 40' Low Floor Regular All-Electric Fixed Route Bus

BID FILE NUMBER: 3604

WR 1. General

Comply _____ Do Not Comply _____

The propulsion system and cooling system shall have a published warranty policy that covers each system and system components. The warranty certificate shall be provided as part of the bid documents, and shall provide the same coverage as that published by the manufactures.

Contractor warrants to City that all parts shall conform to the requirements hereof and shall be free from defects in parts, workmanship and design. If a defect in part is found during the warranty period, the defective part shall be replaced at no cost to City of Fresno. If a defect in workmanship is found during the warranty period, the Contractor shall inspect all buses furnished by Contractor under this contract at no additional cost to City of Fresno. Contractor shall assume all costs associated with warranty work or defects in workmanship (Labor, Parts, Freight, any Travel Expenses, Round trip Towing, Shipping, and etc.). This stipulation for coverage supersedes all other stipulations stated elsewhere in this contract unless otherwise stated. All warranty repairs and services shall be performed by the Contractor or Manufacturer Authorized Representatives within five (5) days of the City's notification to the Contractor.

Contractor and Manufacturer warranty period will not commence until the final acceptance notice to the Contractor, after the thirty (30) day testing and acceptance period per bus is complete. This supersedes any manufacturer in service date stipulation from time of purchase.

All warranties must comply with the warranties that have been stated in Section 7: Warranty Requirements. If the Manufacture's warranties conflict with the warranties stated herein, then provisions of Section 7: Warranty Requirements will take precedence.

WR 2. Contractor Warranty

Comply _____ Do Not Comply _____

Warranties in this document are in addition to any statutory remedies or warranties imposed on the Contractor. Consistent with this requirement, the Contractor warrants and guarantees to the City each complete bus and specific subsystems and components as follows. Performance requirements based on design criteria shall not be deemed a warranty item. Contractor is responsible for all requirements under WR 15. Fleet Defects. If a defect in part is found during the warranty period, the defective part shall be replaced at no cost to the City. If a defect in workmanship is found during the warranty period, the Contractor shall inspect all buses manufactured and assembled by Contractor at no additional cost to the City. Contractor and/or manufacturer representative shall assume all costs associated with warranty work (Labor, Parts, any Travel Expenses, Round trip Towing, etc.). All warranty repairs and services shall be performed by the Contractor or authorized repair facility, within five (5) days of the City of Fresno's notification to the Contractor.

WR 3. Complete Bus

Comply _____ Do Not Comply _____

The complete bus, propulsion system, components, major subsystems and body and chassis structure are warranted to be free from Defects and Related Defects for three (3) years or 150,000 miles, whichever comes first, beginning on the date of revenue service . The warranty is based on regular operation of the bus under the operating conditions prevailing in the City's geographical area.

WR 4. Thermal Management System Warranty

Comply _____ Do Not Comply _____

Thermal management system Warranty (Labor, Parts, Freight, any Travel Expenses, Round trip Towing, Shipping, and etc....) is for three (3) years and unlimited mileage. In addition, Contractor shall provide warranties on all other components and services provided by Manufacturer, with coverage time and mileage intervals which meet or exceed Manufacturer's. The warranty shall be from the manufacturer, all costs and expenses related to the warranty claim shall be assumed by the Contractor in the event where thermal management system manufacturer does not cover.

WR 5. Body and Chassis Structure

Comply _____ Do Not Comply _____

Body, body structure, structural elements of the suspension and powertrain cradle are warranted to be free from Defects and Related Defects for three (3) years or 150,000 miles, whichever comes first.

Primary load-carrying members of the bus structure, including structural elements of the suspension, are warranted against corrosion failure and/or Fatigue Failure sufficient to cause a Class 1 or Class 2 Failure for a period of 12 years or 500,000 miles, whichever comes first.

WR 6. Propulsion System

Comply _____ Do Not Comply _____

Propulsion system Warranty, (Labor, Parts, Freight, any Travel Expenses, Round trip Towing, Shipping, and etc....) is for three (3) years and unlimited mileage. In addition, Contractor shall provide warranties on all other components and services provided by Manufacturer, with coverage time and mileage intervals which meet or exceed Manufacturer's. The propulsion system warranty shall be from the manufacturer, all costs and expenses related to the warranty claim shall be assumed by the Contractor in the event where propulsion system manufacturers does not cover.

WR 7. Battery System

Comply _____ Do Not Comply _____

Contractor shall warranty to the City that it's battery system will be free from defects in material and workmanship for twelve (12) years or 500,000 miles. Contractor agrees to repair or replace defective parts at no cost to the City. The warranty shall apply to all internal components and is covered at 100% for parts, labor, and any associated freight costs within the warranty period. The internal components are not customer serviceable, Manufacturer qualified technicians shall perform all repairs required internal to the pack.

The Battery System is defined as the main high voltage energy storage system and consists of the following:

- Battery modules internal to the battery pack
- Battery management system (BMS) electronics
- Cooling system components internal to the battery pack
- Pack enclosure
- All electrical connections internal to the pack

The Coverage includes replacement of internal affected components under any of the following conditions:

1. Battery System manufacturing defects
2. Loss of capacity in the battery system resulting in less than 70% of original useable capacity as measured by the Manufacturer. In this case all components having a capacity of 75% or less at the time of the lowest capacity component reaching 70% will be replaced.
3. Loss of capacity in the battery system resulting in less than 80% of the original usable capacity and the inability to complete the routes with full function. In this case all

components having a capacity of 83% or less at the time of the lowest components reaching 80% will be replaced.

WR 8. Shop Charging System

Comply _____ Do Not Comply _____

Contractor shall warranty to the City that it's battery system will be free from defects in material and workmanship for three (3) years or 150,000 miles. Contractor agrees to repair or replace defective parts at no cost to the City. The warranty shall apply to all internal components and is covered at 100% for parts. Labor, and any associated freight costs within the warranty period. The internal components are not customer serviceable, Manufacturer qualified technicians shall perform all repairs required internal to the pack.

The shop charging system as referred to in this document is comprised of, but not limited to, the following:

- Main charging equipment
- Vehicle connection cable

WR 9. Subsystems

Comply _____ Do Not Comply _____

Other subsystems shall be warranted to be free from Defects and Related Defects for three (3) years and unlimited miles. Other subsystems are listed below:

- Brake system: Foundation brake components, including advancing mechanisms, as supplied with the axles, excluding friction surfaces.
- Transmission
- Axle
- Traction Motor and Inverter
- Destination signs: All destination sign equipment for the front, side and rear signs, power modules and operator control.
- Heating, ventilating: Roof and/or rear main unit only, excluding floor heaters and front defroster.
- AC unit and compressor: Roof and/or rear main unit only, excluding floor heaters and front defroster.
- Door systems: Door operating actuators and linkages.
- Air compressor.
- Air dryer.
- Wheelchair ramp system: Lift and/or ramp parts and mechanical only.
- Power Converter
- Fire suppression: Fire suppression system including tank and extinguishing agent dispensing system.
- Hydraulic systems: Including radiator fan drive and power steering as applicable.
- Cooling systems: Radiator including core, tanks and related framework, including surge tank.
- Transmission cooler.
- Passenger seating (excluding upholstery).
- Windows
- Energy Storage System (ESS)
- Shop Charge System
- Power Steering
- Surveillance system including cameras and video recorders(if provided by Contractor).

WR 10. Serial Numbers

Comply _____ Do Not Comply _____

Upon delivery of each bus, the Contractor shall provide a complete electronic list of serialized units installed on each bus to facilitate warranty tracking. The list shall include, but is not limited to the following:

- Motor

- Transmission
- Inverters/Converters
- Starter
- A/C compressor and condenser/evaporator unit
- Drive axle
- Power steering unit
- Energy Storage Systems
- Air compressor
- Wheelchair ramp

The Contractor shall provide updated serial numbers resulting from warranty campaigns. The format of the list shall be reviewed by the City prior to delivery of the first production bus.

WR 11. Extension of Warranty

Comply _____ Do Not Comply _____

If, during the warranty period, repairs or modifications on any bus are made necessary by defective design, materials or workmanship but are not completed due to lack of material or inability to provide the proper repair for ten (10) calendar days, then the applicable "Complete Bus" warranty period shall be extended by the contractor the number of days equal to the delay period the bus was out of service.

WR 12. Voiding of Warranty

Comply _____ Do Not Comply _____

The warranty shall not apply to the failure of any part or component of the bus that directly results from misuse, negligence, accident or repairs not conducted in accordance with the Contractor-provided maintenance manuals and with workmanship performed by adequately trained personnel in accordance with recognized standards of the industry. The warranty also shall be void if the City fails to conduct normal inspections and scheduled preventive maintenance procedures as recommended in the Contractor's maintenance manuals and if that omission caused the part or component failure. The City shall maintain documentation, auditable by the Contractor, verifying service activities in conformance with the Contractor's maintenance manuals.

WR 13. Exceptions and Additions to Warranty

Comply _____ Do Not Comply _____

The warranty shall not apply to the following items:

- Scheduled maintenance items
- Normal wear-out items
- Items furnished by the City

Should the City require the use of a specific product and has rejected the Contractor's request for an alternate product, then the standard Supplier warranty for that product shall be the only warranty provided to the City. This product will be eligible under "Fleet Defects," below.

The Contractor shall be required to provide warranty information for all systems, sub-systems, components, and items discussed or mentioned herein or hereof requirements contract

WR 14. Pass-Through Warranty

Comply _____ Do Not Comply _____

At any time during the warranty period, the Contractor may request approval from the City to assign its warranty obligations to others, but only on a case-by-case basis and approved in writing by the City. Otherwise, the Contractor shall be solely responsible for the administration of the warranty as specified. Warranty administration by others does not eliminate the warranty liability and responsibility of the Contractor. Contractor shall state in writing that the City's warranty reimbursements will not be

impacted. The Contractor also shall state in writing any exceptions and reimbursement including all costs incurred due to the transport of vehicle(s) and/or component(s) to and from the warranty facility.

WR 14.1 Superior Warranty

Comply _____ Do Not Comply _____

The Contractor shall pass on to the City any warranty offered by a system, sub-system, item, or component supplier that is superior to that required herein. The Contractor shall provide a list to the City noting the conditions and limitations of the Superior Warranty not later than the start of production. The Superior Warranty shall not be administered by the Contractor.

WR 15. Fleet Defects

WR 15.1 Occurrence and Remedy

Comply _____ Do Not Comply _____

A Fleet Defect is defined as cumulative failures of twenty-five (25) percent of the same components in the same or similar application per bus order, orders may vary in quantity per order, where such items are covered by warranty. When a Fleet Defect is declared, the remaining warranty on that item/component stops. The warranty period does not restart until the Fleet Defect is corrected.

For the purpose of Fleet Defects, each option order shall be treated as a separate bus fleet, orders may vary in quantity per order. In addition, should there be a change in a major component within either the base order or an option order, the buses containing the new major component shall become a separate bus fleet for the purposes of Fleet Defects.

The Contractor shall correct a Fleet Defect under the warranty provisions. After correcting the Defect, the City and the Contractor shall mutually agree to and the Contractor shall promptly undertake and complete a work program reasonably designed to prevent the occurrence of the same Defect in all other buses and spare parts purchased under this Contract. Where the specific Defect can be solely attributed to particular identifiable part(s), the work program shall include redesign and/or replacement of only the defectively designed and/or manufactured part(s). In all other cases, the work program shall include inspection and/or correction of all the buses in the fleet via a mutually agreed-to arrangement. The Contractor shall update, as necessary, technical support information (parts, service and operator's manuals) due to changes resulting from warranty repairs. The City may immediately declare a Defect in design resulting in a safety hazard to be a Fleet Defect. The Contractor shall be responsible to furnish, install and replace all defective units at no cost to the City and Contractor shall incur all cost associated with the repair including, but not limited to, Labor, Parts, any Travel Expenses, Round trip Towing, etc.

WR 15.2 Exceptions to Fleet Defect Provisions

Comply _____ Do Not Comply _____

The Fleet Defect warranty provisions shall not apply to City-supplied items.

WR 16. Repair Performance

Comply _____ Do Not Comply _____

The Contractor is responsible for all warranty-covered repair work. The City will allow the Contractor or its designated representative to perform such work. At its discretion, the City may perform such work if it determines it needs to do so based on transit service or other requirements. Such Work shall be reimbursed by the Contractor.

WR 17. Repairs by the Contractor

Comply _____ Do Not Comply _____

If the City detects a Defect within the warranty periods defined in this section, it shall, within thirty (30) days, notify the Contractor's designated representative. The Contractor or its designated representative shall begin work on warranty-covered repairs within five (5) days after receiving notification of a Defect

from the City. The City shall make the bus available to complete repairs timely with the Contractor's repair schedule. It is hereby agreed that the Contractor shall be liable for and shall pay the amount of **TWO-HUNDRED FIFTY DOLLARS (\$250.00)** per bus per calendar day repair work has not commenced after five (5) days of the notice to Contractor or issue.

The Contractor shall provide at its own expense all spare parts, tools and space required to complete repairs. At the City's option, the Contractor may be required to remove the bus from the City's property while repairs are being effected. If the bus is removed from the City's property, then repair procedures must be diligently pursued by the Contractor's representative.

WR 18. Repairs by the City

Comply _____ Do Not Comply _____

If the Contractor decides to allow the City to perform the work or the City determines it needs to do so based on transit service or other requirements, the Contractor shall accept any and all labor hours that are accrued by City technicians to complete repairs of the bus at the labor rate defined in WR 18.5 Reimbursement for Labor and Other Related Costs. The Contractor shall provide technical support to aid in the diagnoses and repair of the buses and components. In the event that the City performs warranty work, the Contractor shall provide diagnostic charts/tree and repair procedures to assist City staff and technicians.

WR 18.1 Parts Used

Comply _____ Do Not Comply _____

If the City performs the warranty-covered repairs, then it shall correct or repair the Defect and any Related Defects utilizing parts supplied by the Contractor specifically for this repair. At its discretion, the City may use Contractor-specified parts available from its own stock if deemed in its best interests for the City.

WR 18.2 Contractor-Supplied Parts

Comply _____ Do Not Comply _____

The City may require that the Contractor supply parts for warranty-covered repairs being performed by the City. Those parts may be remanufactured but shall have the same form, fit and function, and warranty as new unused parts. The parts shall be shipped prepaid to the City from any source selected by the Contractor within five (5) days of receipt of the request for said parts and shall not be subject to a City handling charge.

WR 18.3 Defective Component Return

Comply _____ Do Not Comply _____

The Contractor may request that parts covered by the warranty be returned to the manufacturing plant no more than forty-five (45) days from the date of repair. The freight costs for this action shall be paid by the Contractor. Materials should be returned in accordance with the procedures outlined in WR 18.1 Warranty Processing Procedures.

WR 18.4 Failure Analysis

Comply _____ Do Not Comply _____

The Contractor shall, upon specific request of the City, provide a failure analysis of Fleet Defect or safety-related parts, or major components, removed from buses under the terms of the warranty that could affect fleet operation. Such reports shall be delivered within thirty (30) days of the receipt of failed parts.

WR 18.5 Reimbursement for Labor and Other Related Costs

Comply _____ Do Not Comply _____

The City shall be reimbursed by the Contractor for labor. The amount shall be determined by the City to cover all expenses including, but not limited to, a mechanic at a straight time wage rate, fringe benefits, and overhead, plus the cost of towing the bus if such action was necessary and if the bus was in the normal service area, 160 percent of the shop labor rate, per person hour required to correct the defect. These wage and fringe benefit rates shall be adjusted based on the rates in effect in the City's service garage at the time the Defect correction is made. The amount determined shall be a minimum labor rate of **\$85.00 per hour**.

WR 18.6 Reimbursement for Parts

Comply _____ Do Not Comply _____

The City shall be reimbursed by the Contractor for defective parts and for parts that must be replaced to correct the Defect. The reimbursement shall be at the current price at the time of repair and shall include taxes where applicable, plus fifteen (15) percent handling costs. Handling costs shall not be paid if parts are supplied by the Contractor and shipped to the City.

WR 18.7 Reimbursement Requirements

Comply _____ Do Not Comply _____

The Contractor shall respond to the warranty claim with an accept/reject decision including necessary failure analysis no later than thirty (30) days after the City submits the claim and defective part(s), when requested. Reimbursement for all accepted claims shall occur no later than thirty (30) days from the date of acceptance of a valid claim. The City may dispute rejected claims or claims for which the Contractor did not reimburse the full amount. The parties agree to review disputed warranty claims during the following quarter to reach an equitable decision to permit the disputed claim to be resolved and closed. The parties also agree to review all claims at least once per quarter throughout the entire warranty period to ensure that open claims are being tracked and properly dispositioned.

WR 19. Warranty after Replacement/Repairs

Comply _____ Do Not Comply _____

If any component, unit or subsystem is repaired, rebuilt or replaced by the Contractor or by the City with the concurrence of the Contractor, then the component, unit or subsystem shall have the unexpired warranty period of the original. Repairs shall not be warranted if Contractor-provided or authorized parts are not used for the repair, unless the Contractor has failed to respond within five (5) days, in accordance with WR 16. Repairs by the Contractor.

If an item is declared to be a Fleet Defect, then the warranty stops with the declaration of the Fleet Defect. Once the Fleet Defect is corrected, the item(s) shall have three (3) months or remaining time and/or miles of the original warranty, whichever is greater. This remaining warranty period shall begin on the repair/replacement date for corrected items on each bus if the repairs are completed by the Contractor or on the date the Contractor provides all parts to the City.

WR 19.1 Warranty Processing Procedures

Comply _____ Do Not Comply _____

The following list represents requirements by the Contractor to the City for processing warranty claims. One failure per bus per claim is allowed.

- Bus number and vin
- Total vehicle life mileage at time of failure
- Date of failure/repair
- Acceptance/in-service date
- Contractor part number and description
- Component serial number
- Description of failure

- All costs associated with each failure/repair (invoices may be required for third-party costs):
 - Towing
 - Road calls
 - Labor
 - Materials
 - Parts
 - Handling
 - Diagnostic time
 - Troubleshooting time

WR 20. Forms

Comply _____ Do Not Comply _____

The City's forms will be accepted by the Contractor if all of the above information is included. Electronic submittal may be used if available between the Contractor and the City.

WR 21. Return of Parts

Comply _____ Do Not Comply _____

When returning defective parts to the Contractor, the City shall tag each part with the following:

- Bus number and VIN
- Claim number
- Part number
- Serial number (if available)

WR 22. Timeframe

Comply _____ Do Not Comply _____

Each claim must be submitted no more than thirty (30) days from the date of failure and/or repair, whichever is later. All defective parts must be returned to the Contractor, when requested, no more than forty-five (45) days from the date of repair.

WR 23. Reimbursements

Comply _____ Do Not Comply _____

The City may request that all warranty claims be used as a credit towards parts, materials, or tooling purchased from the Contractor. Reimbursements are to be transmitted to the following address:

City of Fresno
Department of Transportation/FAX
2223 G St.
Fresno, CA 93706

SECTION 8: QUALITY ASSURANCE

CITY OF FRESNO SPECIFICATIONS

PRODUCT PURCHASE CONTRACT FOR: Two (2) 40' Low Floor Regular All-Electric Fixed Route Bus

BID FILE NUMBER: 3604

QA 1. Contractor's In-Plant Quality Assurance Requirements

QA 1.1 Quality Assurance Organization

Comply _____ Do Not Comply _____

QA 1.1.1 Organization Establishment

The Contractor shall establish and maintain an effective in-plant quality assurance organization. It shall be a specifically defined organization and should be directly responsible to the Contractor's top management.

QA 1.1.2 Control

The quality assurance organization shall exercise quality control over all phases of production, from initiation of design through manufacture and preparation for delivery. The organization shall also control the quality of supplied articles.

QA 1.1.3 Authority and Responsibility

The quality assurance organization shall have the authority and responsibility for reliability, quality control, inspection planning, establishment of the quality control system, and acceptance/rejection of materials and manufactured articles in the production of the transit buses.

QA 1.2 Quality Assurance Organization Functions

Comply _____ Do Not Comply _____

QA 1.2.1 Minimum Functions

The quality assurance organization shall include the following minimum functions:

- **Work Instructions:** The quality assurance organization shall verify inspection operation instructions to ascertain that the manufactured product meets all prescribed requirements.
- **Records Maintenance:** The quality assurance organization shall maintain and use records and data essential to the effective operation of its program. These records and data shall be available for review by the resident inspectors. Inspection and test records for this procurement shall be available for a minimum of one year after inspections and tests are completed.
- **Corrective Action:** The quality assurance organization shall detect and promptly ensure correction of any conditions that may result in the production of defective transit buses. These conditions may occur in designs, purchases, manufacture, tests or operations that culminate in defective supplies, services, facilities, technical data or standards.

QA 1.2.2 Basic Standards and Facilities

The following standards and facilities shall be basic in the quality assurance process:

- **Configuration Control:** The Contractor shall maintain drawings, assembly procedures and other documentation that completely describe a qualified bus that meets all of the options and special requirements of this procurement. The quality assurance organization shall verify that each transit bus is manufactured in accordance with these controlled drawings, procedures and documentation.

- **Measuring and Testing Facilities:** The Contractor shall provide and maintain the necessary gauges and other measuring and testing devices for use by the quality assurance organization to verify that the buses conform to all specification requirements. These devices shall be calibrated at established periods against certified measurement standards that have known, valid relationships to national standards.
- **Production Tooling as Media of Inspection:** When production jigs, fixtures, tooling masters, templates, patterns and other devices are used as media of inspection, they shall be proved for accuracy at formally established intervals and adjusted, replaced or repaired as required to maintain quality.
- **Equipment Use by Resident Inspectors:** The Contractor's gauges and other measuring and testing devices shall be made available for use by the resident inspectors to verify that the buses conform to all specification requirements. If necessary, the Contractor's personnel shall be made available to operate the devices and to verify their condition and accuracy.

QA 1.2.3 Maintenance of Control

The Contractor shall maintain quality control of purchases:

- **Supplier Control:** The Contractor shall require each Supplier to maintain a quality control program for the services and supplies that it provides. The Contractor's quality assurance organization shall inspect and test materials provided by Suppliers for conformance to specification requirements. Materials that have been inspected, tested and approved shall be identified as acceptable to the point of use in the manufacturing or assembly processes. Controls shall be established to prevent inadvertent use of nonconforming materials.
- **Purchasing Data:** The Contractor shall verify that all applicable specification requirements are properly included or referenced in purchase orders of articles to be used on transit buses.

QA 1.2.4 Manufacturing Control

- **Controlled Conditions:** The Contractor shall ensure that all basic production operations, as well as all other processing and fabricating, are performed under controlled conditions. Establishment of these controlled conditions shall be based on the documented Work instructions, adequate production equipment and special working environments if necessary.
- **Completed Items:** A system for final inspection and test of completed transit buses shall be provided by the quality assurance organization. It shall measure the overall quality of each completed bus.
- **Nonconforming Materials:** The quality assurance organization shall monitor the Contractor's system for controlling nonconforming materials. The system shall include procedures for identification, segregation and disposition.
- **Statistical Techniques:** Statistical analysis, tests and other quality control procedures may be used when appropriate in the quality assurance processes.
- **Inspection Status:** A system shall be maintained by the quality assurance organization for identifying the inspection status of components and completed transit buses. Identification may include cards, tags or other normal quality control devices.

QA 1.2.5 Inspection System

The quality assurance organization shall establish, maintain and periodically audit a fully documented inspection system. The system shall prescribe inspection and test of materials, Work in process and completed articles. As a minimum, it shall include the following controls:

- **Inspection Personnel:** Sufficient trained inspectors shall be used to ensure that all materials, components and assemblies are inspected for conformance with the qualified bus design.

- **Inspection Records:** Acceptance, rework or rejection identification shall be attached to inspected articles. Articles that have been accepted as a result of approved materials review actions shall be identified. Articles that have been reworked to specified drawing configurations shall not require special identification. Articles rejected as unsuitable or scrap shall be plainly marked and controlled to prevent installation on the bus. Articles that become obsolete as a result of engineering changes or other actions shall be controlled to prevent unauthorized assembly or installation. Unusable articles shall be isolated and then scrapped. Discrepancies noted by the Contractor or resident inspectors during assembly shall be entered by the inspection personnel on a record that accompanies the major component, subassembly, assembly or bus from start of assembly through final inspection. Actions shall be taken to correct discrepancies or deficiencies in the manufacturing processes, procedures or other conditions that cause articles to be in nonconformity with the requirements of the Contract specifications. The inspection personnel shall verify the corrective actions and mark the discrepancy record. If discrepancies cannot be corrected by replacing the nonconforming materials, then the City shall approve the modification, repair or method of correction to the extent that the Contract specifications are affected.
- **Quality Assurance Audits:** The quality assurance organization shall establish and maintain a quality control audit program. Records of this program shall be subject to review by the City.

QA 2. Inspection

QA 2.1 Inspection Stations

Comply _____ Do Not Comply _____

Inspection stations shall be at the best locations to provide for the Work content and characteristics to be inspected. Stations shall provide the facilities and equipment to inspect structural, electrical, hydraulic and other components and assemblies for compliance with the design requirements.

Stations shall also be at the best locations to inspect or test characteristics before they are concealed by subsequent fabrication or assembly operations. These locations shall minimally include underbody structure completion, body framing completion, body prior to paint preparation, water test, engine installation completion, underbody dress-up and completion, bus prior to final paint touchup, bus prior to road test and bus final road test completion.

QA 2.2 Resident Inspectors

Comply _____ Do Not Comply _____

QA 2.2.1 Resident Inspector's Role

The City shall be represented at the Contractor's plant by resident inspectors, as required by FTA. Resident inspectors may be City employees or outside contractors. The City shall provide the identity of each inspector and shall also identify his or her level of authority in writing. They shall monitor, in the Contractor's plant, the manufacture of transit buses built under the procurement. The presence of these resident inspectors in the plant shall not relieve the Contractor of its responsibility to meet all the requirements of this procurement. The City shall designate a primary resident inspector, whose duties and responsibilities are delineated in "Pre-Production Meetings," "City" and "Pre-Delivery Tests," below. Contractor and resident inspector relations shall be governed by the guidelines included as Attachment A to this section.

QA 2.2.2 Pre-Production Meetings

The primary resident inspector may participate in design review and Pre-Production Meetings with the City. At these meetings, the configuration of the buses and the manufacturing processes shall be finalized, and all Contract documentation provided to the inspector.

No less than thirty (30) days prior to the beginning of bus manufacture, the primary resident inspector may meet with the Contractor's quality assurance manager and may conduct a pre-production audit

meeting. They shall review the inspection procedures and finalize inspection checklists. The resident inspectors may begin monitoring bus construction activities two weeks prior to the start of bus fabrication.

QA 2.2.3 Authority

Records and data maintained by the quality assurance organization shall be available for review by the resident inspectors. Inspection and test records for this procurement shall be available for a minimum of one year after inspections and tests are completed.

The Contractor's gauges and other measuring and testing devices shall be made available for use by the resident inspectors to verify that the buses conform to all specification requirements. If necessary, the Contractor's personnel shall be made available to operate the devices and to verify their condition and accuracy.

Discrepancies noted by the resident inspector during assembly shall be entered by the Contractor's inspection personnel on a record that accompanies the major component, subassembly, assembly or bus from start of assembly through final inspection. Actions shall be taken to correct discrepancies or deficiencies in the manufacturing processes, procedures or other conditions that cause articles to be in nonconformity with the requirements of the Contract specifications. The inspection personnel shall verify the corrective actions and mark the discrepancy record. If discrepancies cannot be corrected by replacing the nonconforming materials, then the City shall approve the modification, repair or method of correction to the extent that the Contract specifications are affected.

The primary resident inspector shall remain in the Contractor's plant for the duration of bus assembly Work under this Contract. Only the primary resident inspector or designee shall be authorized to release the buses for delivery. The resident inspectors shall be authorized to approve the pre-delivery acceptance tests. Upon request to the quality assurance supervisors, the resident inspectors shall have access to the Contractor's quality assurance files related to this procurement. These files shall include drawings, assembly procedures, material standards, parts lists, inspection processing and reports, and records of Defects.

QA 2.2.4 Support Provisions

The Contractor shall provide office space for the resident inspectors in close proximity to the final assembly area. This office space shall be equipped with desks, outside and interplant telephones, Internet access, file cabinet and chairs.

QA 2.2.5 Compliance with Safety Requirements

At the time of the Pre-Production Meeting, the Contractor shall provide all safety and other operational restrictions that govern the Contractor's facilities. These issues will be discussed and the parties will agree which rules/restrictions will govern the City's inspector(s) and any other City representatives during the course of the Contract.

QA 3. Acceptance Tests

QA 3.1 Responsibility

Comply _____ Do Not Comply _____

Fully documented tests shall be conducted on each production bus following manufacture to determine its acceptance to the City. These acceptance tests shall include pre-delivery inspections and testing by the Contractor and inspections and testing by the City after the buses have been delivered.

QA 3.2 Pre-Delivery Tests

Comply _____ Do Not Comply _____

The Contractor shall conduct acceptance tests at its plant on each bus following completion of manufacture and before delivery to the City. These pre-delivery tests shall include visual and measured

inspections, as well as testing the total bus operation. The tests shall be conducted and documented in accordance with written test plans reviewed by the City.

Additional tests may be conducted at the Contractor's discretion to ensure that the completed buses have attained the required quality and have met the requirements in "Section 6: Technical Specifications." The City may, prior to commencement of production, demand that the Contractor demonstrate compliance with any requirement in that section if there is evidence that prior tests have been invalidated by the Contractor's change of Supplier or change in manufacturing process. Such demonstration shall be by actual test, or by supplying a report of a previously performed test on similar or like components and configuration. Any additional testing shall be recorded on appropriate test forms provided by the Contractor and shall be conducted before acceptance of the bus.

The pre-delivery tests shall be scheduled and conducted with thirty (30) days' notice so that they may be witnessed by the resident inspectors, who may accept or reject the results of the tests. The results of pre-delivery tests, and any other tests, shall be filed with the assembly inspection records for each bus. The under floor equipment shall be available for inspection by the resident inspectors, using a pit or bus hoist provided by the Contractor. A hoist, scaffold or elevated platform shall be provided by the Contractor to easily and safely inspect bus roofs. Delivery of each bus shall require written authorization of the primary resident inspector. Authorization forms for the release of each bus for delivery shall be provided by the Contractor. An executed copy of the authorization shall accompany the delivery of each bus.

QA 3.2.1 Visual and Measured Inspections

Visual and measured inspections shall be conducted with the bus in a static condition. The purpose of the inspection testing includes verification of overall dimension and weight requirements, that required components are included and are ready for operation, and that components and subsystems designed to operate with the bus in a static condition do function as designed.

QA 3.2.2 Total Bus Operation

Total bus operation shall be evaluated during road tests. The purpose of the road tests is to observe and verify the operation of the bus as a system and to verify the functional operation of the subsystems that can be operated only while the bus is in motion.

Each bus shall be driven for a minimum of fifteen (15) miles during the road tests. If requested, computerized diagnostic printouts showing the performance of each bus shall be produced and provided to the City. Observed Defects shall be recorded on the test forms. The bus shall be retested when Defects are corrected and adjustments are made. This process shall continue until Defects or required adjustments are no longer detected.

QA 4. City-Specific Requirements

QA 4.1 CAD/AVL Inspection Sign-Off

Comply _____ Do Not Comply _____

Trapeze ITS will perform an Acceptance Test Procedure (ATP) of the CAD/AVL installation at the OEM facility while the vehicles are in the production line. Once the vehicles have arrived at the FAX facility Trapeze ITS will perform the final ATP on the vehicles prior to releasing the vehicles to revenue service. This process should be included as part of the CAD/AVL procurement pricing. This item should be discuss in detailed with a copy of the ATP process during the pre-production meeting.

QA 5. Bus Manufacturing Inspection Guidelines

QA 5.1 Pre-Production Meeting

Comply _____ Do Not Comply _____

QA 5.1.1 Responsibilities

QA 5.1.1.1 City

- Provides conformed copy of technical requirements.
- Recommended staff to be involved may include the following:
 - Project manager
 - Technical engineer
 - Contract administrator
 - Quality assurance administrator
 - Warranty administrator
- Process for inspector's role (to deal with City) for negotiated changes after freeze date.
- Contractual requirements:
 - Milestones
 - Documentation
 - Title requirements
 - Deliverables
 - Payments
 - Reliability tracking

QA 5.1.1.2 Manufacturer

- Identifies any open issues.
- Recommended staff to be involved may include the following:
 - Project manager
 - Technical engineer(s)
 - Contract administrator
 - Quality assurance administrator
 - Warranty administrator
- Production flow (buses/week, shifts).
- Delivery schedule and offsite component build-up schedule.
- Bus QA documentation (including supplier application approvals and/or any certifications required for the specific production).
- Communication flow/decision making.

QA 5.1.1.3 Inspector

- Agree on decisions inspectors can and cannot make.
- Primary contact for problems, etc.
- Production flow process (description of manufacturing by station).
- Factory hours (manage inspection schedule based on production hours).
- Plant rules.
- Safety requirements.
- Orientation requirements.
- Work environment.
- Inspector's office space (per contract).

NOTE: As a result of this meeting, documentation should be produced detailing final production requirements and the planned configuration of the bus.

QA 5.2 Build Schedule

Comply _____ Do Not Comply _____

The bus manufacturer's contract administrator shall supply a fleet build production schedule based on the dates in the Notice to Proceed, and a description of the manufacturer's schedule for plant operations.

The production schedule should contain specific milestone dates, such as the following:

- First vehicle on production line (date on which any work will begin).
- First vehicle off production line.
- First vehicle through manufacturer's quality assurance inspections.
- First vehicle shipped to the City.
- Last vehicle on production line.
- Last vehicle off production line.
- Last vehicle shipped to the City.

QA 5.3 Plant Tour

Comply _____ Do Not Comply _____

The City will review the entire process from start to finish and review the work completed at each line station, including quality control measures.

QA 5.4 Prototype/Pilot Vehicle Production

Comply _____ Do Not Comply _____

The Contractor shall conduct acceptance tests at its plant on each bus following completion of manufacture and before delivery to the City. These pre-delivery tests shall include visual and measured inspections, as well as testing the total bus operation. The tests shall be conducted and documented in accordance with written test plans reviewed by the City. The under floor equipment shall be available for inspection by the resident inspectors, using a pit or bus hoist provided by the Contractor. A hoist, scaffold or elevated platform shall be provided by the Contractor to easily and safely inspect bus roofs. Delivery of each bus shall require written authorization of the primary resident inspector. Authorization forms for the release of each bus for delivery shall be provided by the Contractor. An executed copy of the authorization shall accompany the delivery of each bus.

Additional tests may be conducted at the City's discretion to ensure that the completed buses have attained the required quality and have met the requirements in "Section 6: Technical Specifications." The City may, prior to commencement of production, demand that the Contractor demonstrate compliance with any requirement in that section if there is evidence that prior tests have been invalidated by the Contractor's change of Supplier or change in manufacturing process. Such demonstration shall be by actual test, or by supplying a report of a previously performed test on similar or like components and configuration. Any additional testing shall be recorded on appropriate test forms provided by the Contractor and shall be conducted before acceptance of the bus.

The pre-delivery tests shall be scheduled and conducted with 30 days' notice so that they may be witnessed by the resident inspectors, who may accept or reject the results of the tests. The results of pre-delivery tests, and any other tests, shall be filed with the assembly inspection records for each bus.

QA 5.5 Visual and Measured Inspections

Comply _____ Do Not Comply _____

Visual and measured inspections shall be conducted with the bus in a static condition. The purpose of the inspection testing includes verification of overall dimension and weight requirements, that required components are included and are ready for operation, and that components and subsystems designed to operate with the bus in a static condition do function as designed.

QA 5.6 Total Bus Operation

Comply _____ Do Not Comply _____

Total bus operation shall be evaluated during road tests. The purpose of the road tests is to observe and verify the operation of the bus as a system and to verify the functional operation of the subsystems that can be operated only while the bus is in motion.

Each bus shall be driven for a minimum of 15 miles during the road tests. If requested, computerized diagnostic printouts showing the performance of each bus shall be produced and provided to the City. Observed defects shall be recorded on the test forms. The bus shall be retested when defects are corrected and adjustments are made. This process shall continue until defects or required adjustments are no longer detected.

QA 5.6.1 Post-Delivery Tests

The City shall conduct acceptance tests on each delivered bus. These tests shall be completed within 30 days after bus delivery and shall be conducted in accordance with the City's written test plans. The purpose of these tests is to identify defects that have become apparent between the time of bus release and delivery to the City. The post-delivery tests shall include visual inspection and bus operations. No post-delivery test shall apply new criteria that are different from criteria applied in a pre-delivery test.

Buses that fail to pass the post-delivery tests are subject to non-acceptance. The City shall record details of all defects on the appropriate test forms and shall notify the Contractor of acceptance or non-acceptance of each bus, after completion of the tests. The defects detected during these tests shall be repaired according to procedures defined in the contract.

QA 5.6.2 Prototype/Pilot Vehicle Acceptance

In order to assess the Contractor's compliance with the Technical Specifications, the City and the Contractor shall, at the Pre-Production Meeting, jointly develop a Configuration and Performance Review document for review of the pilot vehicle. This document shall become part of the official record of the Pre-Production Meeting.

Potential dimensional/performance tests that may be included in the Configuration and Performance Review include the following:

- Complete electrical system audit
- Dimensional requirements audit
- Electrical system audit
- Seating capacity
- Water test
- Water runoff test
- Function test of systems/subsystems and components
- Sound/noise level tests
- Vehicle top speed
- Acceleration tests
- Brake stop tests
- Airflow tests
- PA function tests
- Air/brake system audit
- Individual axle weight
- Standee capacity
- Body deflection tests
- Silent alarm function test
- Interior lighting
- Exterior lighting
- Gradability test
- Kneeling system function

- HVAC pull-down/heat
- Speedometer
- Outside air infiltration (smoke)
- Wheelchair ramps
- Engine performance qualification
 - This test shall be jointly conducted by the Contractor and the propulsion system manufacturer(s) (including but not limited to air to boil test, loss of coolant, energy storage system, electrical inputs and propulsion system protection system).
- Transmission performance qualifications
 - This test shall be jointly conducted by the Contractor and the transmission manufacturer (including but not limited to retarder operation, heat exchanger, interface with ABS and electrical inputs).

QA 5.7 Buy America Audit

Comply _____ Do Not Comply _____

A post-delivery Buy America audit is required for federally funded bus procurements (see 49 CFR Part 663 for additional information). The onsite resident inspectors are to monitor the production processes to verify compliance with final assembly requirements identified by the Buy America pre-award audit. This audit is to verify compliance with final assembly requirements and final documentation of Buy America compliance and must be completed prior to title transfer.

NOTE: If there is not a pilot/prototype bus, then the Buy America post-delivery audit should be performed following completion of the first serial production bus. In addition to monitoring of the production processes, the City must verify compliance that more than 60 percent of the costs of all components are produced in the United States. Finally, the City must execute the required certificates.

QA 5.8 Resident Inspection Process for Serial Production

Comply _____ Do Not Comply _____

At the discretion of the City, a decision is made to perform resident inspection using the City's personnel, a contract inspector, or a combination of both. The decision is based on factors such as the availability of personnel, knowledge/expertise in bus build project management, the size of the bus order, etc.

NOTE: The decision to have the resident inspection performed by City personnel results in a firm understanding and knowledge of the bus and affords the opportunity to identify parts that will be needed for general maintenance down the road.

QA 5.8.1 Inspector Responsibilities

The resident inspection process for the serial production of the buses begins following the completion and acceptance of the prototype or pilot vehicle if required, or according to the serial bus production schedule. Resident inspectors should represent the City for all build-related issues (quality, conformance, etc.). Resident inspectors can also address contractual type issues but should only do so under the consult of the City's contracts administrator. Resident inspectors are sent to the manufacturer's facility according to a Resident Inspection Schedule. Typically, one or two inspectors arrive onsite at the manufacturing facility about one week prior to actual production to setup the resident inspection process and to begin preliminary quality assurance inspections for items such as power plant build-up and wire harness production, and to inspect incoming parts, fasteners, fluids, etc., that will be used in the production of the buses. During the serial production of the buses, the resident inspectors should monitor the production of each bus, verifying the quality of materials, components, sub-assemblies and manufacturing standards. In addition, the configuration of each vehicle should be audited using the vehicle manufacturer's Build Specification and other documents to ensure contract compliance and uniformity.

QA 5.8.2 Inspector Rotation/Scheduling

During the resident inspection phase, a single inspector or multiple inspectors could be used. If it is decided to use multiple inspectors, then the inspectors could be rotated on a biweekly to monthly basis as required. During the rotation of inspectors, a sufficient period of overlap should be provided to guarantee the consistency of the resident inspection process.

QA 5.8.3 Resident Inspector Orientation

A resident inspector orientation by the bus manufacturer should take place upon the arrival of the initial inspection team. The orientation should include expectations for the use of personal protective equipment (safety shoes, safety glasses, etc.), daily check-in and check-out requirements, lines of communication, use of production documents such as speed memos and line movement charts, inspector/production meetings, inspector office arrangements, and anything else pertinent to the inspection team's involvement during the build. Many of the above items should already be formalized during the Pre-Production Meeting.

QA 5.8.4 Audits, Inspections and Tests

The resident inspection process monitors the production of each vehicle. Inspection stations should be strategically placed to test or inspect components or other installations before they are concealed by subsequent fabrication or assembly operations. These locations typically are placed for the inspection of underbody structure, body framing, electrical panels and harnesses, air and hydraulic line routings, installation of insulation, power plant build-up and installation, rust inhibitor/undercoating application, floor installation, front suspension alignment, and other critical areas.

QA 5.9 Vehicle Inspections

Comply _____ Do Not Comply _____

Vehicle inspections must be performed by the contractor throughout the assembly process in accordance with the Contractor's QA plan and procedure. The City's inspector(s), in addition to on-going inspections and audits during the vehicle assembly, will identify critical hold points for inspection. The vehicle manufacturer performs its own quality assurance inspections following assembly line completion before releasing each bus to the resident inspectors. The inspections for each vehicle are documented, signed off upon passing and included in the vehicle record.

These are the typical inspections performed on each bus by the resident inspectors:

- Water test inspection
- Road test inspection
- Interior inspection (including functionality)
- Hoist/undercarriage inspection
- Exterior inspection (including roof)
- Electrical inspection
- Wheelchair ramp/lift inspection

QA 5.9.1 Water Test Inspection

The water test inspection checks the integrity of the vehicle's body seams, window frame seals and other exterior component close-outs for their ability to keep rainwater, road splash, melting snow and slush, and other exterior water from entering the inside of the vehicle. The vehicle's interior is inspected for signs of moisture and water leaks. To perform the leak inspection, interior ceiling and side panels are removed, and access doors are opened. If any moisture or water is detected, then the source of the leak will be located and repaired by the manufacturer, and the vehicle will be tested again.

QA 5.9.2 Road Test Inspection

The road test inspection checks all the vehicle's systems and subsystems while the vehicle is in operation. Typically, the road test inspection is performed immediately following the water test inspection to reveal any standing water that may be present due to a leak, but was not noticed during the "static" water test. Objectionable vibrations, air leakage and other factors that affect ride quality are recorded and reported to the vehicle manufacturer for resolution. Vehicle stability, performance, braking and interlock systems, HVAC, and other critical areas are checked to ensure that the vehicle is complete and ready to provide safe and reliable service.

The following tests may be performed and recorded during the road test:

- Acceleration test
- Top speed test
- Gradability test
- Service brake test
- Parking brake test
- Turning effort test
- Turning radius test
- Shift quality
- Quality of retarder or regenerative braking action

During the road test, a vehicle may be taken to a weigh station to record the vehicle's front axle weight, rear axle weight and total vehicle (curb) weight.

QA 5.9.3 Interior Inspection

The interior inspection checks the fit and finish of the interior installations.

In addition, the inspection also verifies the installation and function of systems and subsystems according to the Build Specification. All systems and functions accessed from the interior are inspected for functionality, appearance and safety.

Examples of systems/functions inspected include the following:

- Interior and exterior lighting controls
- Front and rear door systems
- Flooring installation
- Passenger and operator's seat systems
- Wheelchair securement and ramp systems
- Fire suppression system
- Electrical installations (multiplex, tell-tale wiring, panels, etc.)
- Window systems and emergency escape portals
- Operator dash/side panel controls/indicators

QA 5.9.4 Hoist/Undercarriage Inspection

The hoist/undercarriage inspection checks the installation of components, wiring, air lines, presence of fluid leaks, etc., located under the vehicle. Typically, this inspection is performed following the road test. The vehicle is lifted onto a hoist or pulled over a pit for the inspection. Areas inspected are the front suspension, air bags, airline routings, electrical connections and routings, drivetrain components, linkages and any other system or component that may be prone to early failure due to inadequate installation techniques. All lines, cables, hoses, etc., are inspected for proper securement and protection to prevent rubbing, chafing or any other condition that could result in a failure. The engine/power plant and HVAC compartments are also inspected during this time.

QA 5.9.5 Exterior Inspection

The exterior inspection checks the fit and finish of components installed on the exterior of the vehicle. Access panels are opened and accessories are inspected for proper installation. In addition, vehicle paint, graphics and proper decals are also inspected. Acceptable paint finish quality (orange peel, adhesion, etc.) should be agreed on with the vehicle manufacturer prior to production to ensure consistency of inspections.

QA 5.9.6 Electrical Inspection

The vehicle's main electrical panels and other subpanels are inspected for proper components, to include relays, fuses, modules, terminal strips, decals, etc. In addition, electrical harnesses are inspected for proper wiring and termination techniques, bulkhead protection, looming and other items that could result in future electrical failure. Onboard vehicle compartment schematics are verified for accuracy.

QA 5.9.7 Wheelchair Ramp Inspection

The wheelchair ramp assembly is inspected for proper installation and performance. Clearances critical to the operation of the ramp are verified, and the ramp's electrical systems are inspected to ensure appropriate wire routings and protection. The successful integration of the ramp assembly into the vehicle is verified, and the vehicle interlocks are checked during automatic and manual ramp operation.

QA 5.10 Audits

Comply _____ Do Not Comply _____

During serial production of the bus's quality assurance inspection, tests may be performed to ensure that the manufacturer's quality standards are being followed. These inspection audits could be on items such as torque wrench calibrations, proper techniques for fastener installations, proper use and type of adhesives, use of correct installation drawings on the production line, etc.

QA 5.11 Communications

Comply _____ Do Not Comply _____

The lines of communications, formal and informal, should be discussed and outlined in the Pre-Production Meeting. As previously discussed, resident inspectors should represent the City for all bus-build related issues (quality, conformance, etc.). Resident inspectors can relay communications addressing contractual type issues but should do so only under the consult of the City's contract administrator. Actual personnel contacts for the manufacturing facility should be established during resident inspector orientation. These contacts could include quality assurance, production, material handling, engineering and buy-off area personnel.

QA 5.12 Documentation

Comply _____ Do Not Comply _____

The following documents/reports are typically generated during the bus build process:

- Vehicle build specification
- Sales order
- Pre-Production Meeting notes
- Prototype and production correspondence (vehicle build file)
- Manufacturer's vehicle record (Warranty file)
 - Vehicle line documents
 - Serialization documents (Warranty file)
 - Alignment verification
 - Brake testing
 - HVAC testing and checkout
 - Manufacturer's QA checklist and signoff

- Weight slip (prototype and Warranty file)
- Prototype performance tests document (vehicle build file)
 - Acceleration Test
 - Top Speed Test
 - Gradability Test
 - Interior Noise Test A – Stationary
 - Interior Noise Test B – Dynamic
 - Exterior Noise Test A – Pull Away
 - Exterior Noise Test B – Pass-By
 - Exterior Noise Test C – Curb Idle
 - Turning Radius Test
 - Turning Effort Test
 - Parking Brake Test
 - Service Brake Test
- Vehicle acceptance inspections—production (Warranty file)
 - Water Test Inspection Report
 - Road Test Inspection Report
 - Interior Inspection Report
 - Hoist/Undercarriage Inspection Report
 - Exterior Inspection Report
 - Electrical Inspection Report
 - Wheelchair Inspection Report
- Speed Memos (Warranty file)
- City Vehicle Inspection record(Warranty file)
- Release for delivery documentation (Warranty file)
- Post-Production Acceptance – Certificate of Acceptance(Accounting)
- Post-Delivery Inspection Report – (Fleet Management & Warranty files)

QA 5.13 Vehicle Release for Delivery

Comply _____ Do Not Comply _____

Upon satisfactory completion of all inspection, audit and test criteria, and resolution of any outstanding issues affecting the purchase of any or all buses, proper documentation (the Release for Delivery) is signed by the designated resident inspector authorizing the bus manufacturer to deliver the vehicle to the City's facility, where it will undergo a post-delivery inspection process and final acceptance. The satisfactory sign-off of the Release for Delivery should complete the resident inspector's duties for each bus. In final preparation for delivery, the bus manufacturer may request the resident inspector to do a final walk-through of the bus after it has been cleaned and prepped for shipping.

QA 5.13.1 Post-Delivery and Final Acceptance

The City shall conduct acceptance tests on each delivered bus. These tests shall be completed within 15 days after bus delivery and shall be conducted in accordance with the City's written test plans. The purpose of these tests is to identify defects that have become apparent between the time of bus release and delivery to the City. The post-delivery tests shall include visual inspection, along with a verification of system(s) functionality and overall bus operations. No post-delivery test shall apply new criteria that are different from criteria applied in a pre-delivery test.

Buses that fail to pass the post-delivery tests are subject to non-acceptance. The City shall record details of all defects on the appropriate test forms and shall notify the Contractor of acceptance or non-acceptance of each bus within five days after completion of the tests. The defects detected during these tests shall be repaired according to procedures defined in the contract after non-acceptance.

QA 5.13.2 Certificate of Acceptance

- **Accepted**
- **Not Accepted:** In the event that the bus does not meet all requirements for acceptance. The City must identify reasons for non-acceptance and work with the OEM to develop a timeline of addressing the problem for a satisfactory resolution and redelivery.
- **Conditional Acceptance:** In the event that the bus does not meet all requirements for acceptance, the City may conditionally accept the bus and place it into revenue service pending receipt of Contractor furnished materials and/or labor necessary to address the identified issue(s).

SECTION 9: FORMS AND CERTIFICATIONS

CER 1. Acknowledgement of Addenda

Failure to acknowledge receipt of all addenda may cause the Bid to be considered nonresponsive to the Solicitation. Acknowledged receipt of each addendum must be clearly established and included with the Bid.

The Undersigned acknowledges receipt of the following addenda to the documents:

Addendum No.:	_____	Dated:	_____
Addendum No.:	_____	Dated:	_____
Addendum No.:	_____	Dated:	_____
Addendum No.:	_____	Dated:	_____
Addendum No.:	_____	Dated:	_____
Addendum No.:	_____	Dated:	_____
Addendum No.:	_____	Dated:	_____
Addendum No.:	_____	Dated:	_____
Addendum No.:	_____	Dated:	_____
Addendum No.:	_____	Dated:	_____
Addendum No.:	_____	Dated:	_____
Addendum No.:	_____	Dated:	_____
Addendum No.:	_____	Dated:	_____
Addendum No.:	_____	Dated:	_____
Addendum No.:	_____	Dated:	_____

Company Name

Business Address

City State Zip Code

Type or Print Name of Authorized Person and Title

Signature of Authorized Person Date

BIDDER'S NAME: _____
(Submit with Bid Proposal)

CER 2. Federal Certifications

CER 2.1 Statement of Acceptance of All Federal Conditions or Requirements

PRODUCT PURCHASE CONTRACT FOR:
Two (2) 40' Low Floor Regular All-Electric Fixed Route Bus

BID FILE NUMBER: 3604

The Proposer shall sign below the Proposer accepts in whole the Federal Conditions or Requirements set forth in these specifications.

Note: Award will only be made to Proposers who meet all Federal conditions and requirements in full.

- ACCEPT**
- DO NOT ACCEPT**

If "DO NOT ACCEPT" is checked, please list exceptions:

(INSERT IF APPLICABLE) _____

Type or Print Name of Authorized Person and Title

Signature of Authorized Person

Date

CER 2.2 Buy America Certification

In accordance with 49 C.F.R. § 661.6, for the procurement of steel, iron or manufactured products, use the certifications below.

Certificate of Compliance with Buy America Requirements

The bidder or offeror hereby certifies that it will comply with the requirements of 49 U.S.C. 5323(j)(1), and the applicable regulations in 49 C.F.R. part 661.

Date: _____

Signature: _____

Company: _____

Name: _____

Title: _____

Certificate of Non-Compliance with Buy America Requirements

The bidder or offeror hereby certifies that it cannot comply with the requirements of 49 U.S.C. 5323(j), but it may qualify for an exception to the requirement pursuant to 49 U.S.C. 5323(j)(2), as amended, and the applicable regulations in 49 C.F.R. § 661.7.

Date: _____

Signature: _____

Company: _____

Name: _____

Title: _____

In accordance with 49 C.F.R. § 661.12, for the procurement of rolling stock (including train control, communication, and traction power equipment) use the following certifications:

Certificate of Compliance with Buy America Rolling Stock Requirements

The bidder or offeror hereby certifies that it will comply with the requirements of 49 U.S.C. 5323(j), and the applicable regulations of 49 C.F.R. § 661.11.

Date: _____

Signature: _____

Company: _____

Name: _____

Title: _____

Certificate of Non-Compliance with Buy America Rolling Stock Requirements

The bidder or offeror hereby certifies that it cannot comply with the requirements of 49 U.S.C. 5323(j), but may qualify for an exception to the requirement consistent with 49 U.S.C. 5323(j)(2)(C), and the applicable regulations in 49 C.F.R. § 661.7.

Date: _____

Signature: _____

Company: _____

Name: _____

Title: _____

CER 2.3 Debarment and Suspension Certification for Prospective Contractor

Choose one alternative:

- The Bidder, _____, certifies to the best of its knowledge
Name
and belief that it and its principals:
1. Are not presently debarred, suspended, proposed for debarment, declared ineligible, or voluntarily excluded from covered transactions by any federal department or City;
 2. Have not within a three-year period preceding this Bid been convicted of or had a civil judgment rendered against them for commission of fraud or a criminal offense in connection with obtaining, attempting to obtain, or performing a public (federal, state or local) transaction or Contract under a public transaction; violation of federal or state antitrust statutes or commission or embezzlement, theft, forgery, bribery, falsification or destruction of records, making false statements, or receiving stolen property;
 3. Are not presently indicted for or otherwise criminally or civilly charged by a governmental entity (federal, state, or local) with commission of any of the offenses enumerated in Paragraph 2 of this certification; and
 4. Have not within a three-year period preceding this Bid had one or more public transactions (federal, state or local) terminated for cause or default.

OR

- The Bidder is unable to certify to all of the statements in this certification, and attaches its explanation to this certification. (In explanation, certify to those statements that can be certified to and explain those that cannot.)

The Bidder certifies or affirms the truthfulness and accuracy of the contents of the statements submitted on or with this certification and understands that the provisions of Title 31 USC § Sections 3801 are applicable thereto.

Executed in _____
City State Zip Code

Type or Print Name of Authorized Person and Title

Signature of Authorized Person Date

BIDDER'S NAME: _____
(Submit with Bid Proposal)

CER 2.4 Debarment and Suspension Certification (Lower-Tier Covered Transaction

- The prospective lower-tier participant (Bidder) certifies, by submission of this Bid, that neither it nor its "principals" as defined at 49 CFR § 29.105(p) is presently debarred, suspended, proposed for debarment, declared ineligible, or voluntarily excluded from participation in this transaction by any federal department or City.

If the prospective Bidder is unable to certify to the statement above, it shall attach an explanation, and indicate that it has done so by placing an "X" in the following space: _____

THE BIDDER, _____, CERTIFIES OR AFFIRMS THE TRUTHFULNESS AND ACCURACY OF EACH STATEMENT OF ITS CERTIFICATION AND EXPLANATION, IF ANY. IN ADDITION, THE BIDDER UNDERSTANDS AND AGREES THAT THE PROVISIONS OF 31 USC §§ 3801 ET SEQ. APPLY TO THIS CERTIFICATION AND EXPLANATION, IF ANY.

Type or Print Name of Authorized Person and Title

Signature of Authorized Person

Date

CER 2.5 Lobbying Certification

The undersigned certifies, to the best of his or her knowledge and belief, that:

1. No Federal appropriated funds have been paid or will be paid, by or on behalf of the undersigned, to any person for influencing or attempting to influence an officer or employee of an CITY, a Member of Congress, an officer or employee of Congress, or an employee of a Member of Congress in connection with the awarding of any Federal contract, the making of any Federal grant, the making of any Federal loan, the entering into of any cooperative agreement, and the extension, continuation, renewal, amendment, or modification of any Federal contract, grant, loan, or cooperative agreement.
2. If any funds other than Federal appropriated funds have been paid or will be paid to any person for influencing or attempting to influence an officer or employee of any CITY, a Member of Congress, an officer or employee of Congress, or an employee of a Member of Congress in connection with this Federal contract, grant, loan, or cooperative agreement, the undersigned shall complete and submit Standard Form-LLL, "Disclosure Form to Report Lobbying," in accordance with its instructions.
3. The undersigned shall require that the language of this certification be included in the award documents for all sub-awards at all tiers (including subcontracts, sub-grants, and contracts under grants, loans, and cooperative agreements) and that all subrecipients shall certify and disclose accordingly.

This certification is a material representation of fact upon which reliance was placed when this transaction was made or entered into. Submission of this certification is a prerequisite for making or entering into this transaction imposed by section 1352, title 31, U.S. Code. Any person who fails to file the required certification shall be subject to a civil penalty of not less than \$10,000 and not more than \$100,000 for each such failure.

Type or Print Name of Authorized Person and Title

Signature of Authorized Person Date

CER 2.6 Certificate of Compliance with Bus Testing Requirement

The undersigned certifies that the vehicle offered in this procurement complies and will, when delivered, comply with 49 USC § 5323(c) and FTA's implementing regulation at 49 CFR Part 665 according to the indicated one of the following three alternatives.

Mark one and only one of the three blank spaces with an "X."

1. _____ The buses offered herewith have been tested in accordance with 49 CFR Part 665 on _____ (date). If multiple buses are being proposed, provide additional bus testing information below or on attached sheet. The vehicles being sold should have the identical configuration and major components as the vehicle in the test report, which must be submitted with this Bid. If the configuration or components are not identical, then the manufacturer shall provide with its Bid a description of the change and the manufacturer's basis for concluding that it is not a major change requiring additional testing. If multiple buses are being proposed, testing data on additional buses shall be listed on the bottom of this page.

2. _____ The manufacturer represents that the vehicle is "grandfathered" (has been used in mass transit service in the United States before October 1, 1988, and is currently being produced without a major change in configuration or components), and submits with this Bid the name and address of the recipient of such a vehicle and the details of that vehicle's configuration and major components.

3. _____ The vehicle is a new model and will be tested and the results will be submitted to the City prior to acceptance of the first bus.

The undersigned understands that misrepresenting the testing status of a vehicle acquired with federal financial assistance may subject the undersigned to civil penalties as outlined in the Department of Transportation's regulation on Program Fraud Civil Remedies, 49 CFR Part 31. In addition, the undersigned understands that FTA may suspend or debar a manufacturer under the procedures in 49 CFR Part 29.

Company Name

Type or Print Name of Authorized Person and Title

Signature of Authorized Person

Date

BIDDER'S NAME: _____
(Submit with Bid Proposal)

CER 2.7 DBE Approval Certification

The Bidder hereby certify that the transit vehicle(s) to be provided under this bid will be provided by a manufacturer which is in compliance with Special Provisions for Transit Vehicle Manufacturers, Title 49 of the Code of Federal Regulations, Part 26, Subpart C, Section 26.49, Participation by Disadvantaged Business Enterprises in DOT Programs, and that its goals have not been disapproved by the Federal Transit Administration.

Company Name

Type or Print Name of Authorized Person and Title

Signature of Authorized Person

Date

BIDDER'S NAME: _____
(Submit with Bid Proposal)

CER 2.8 Federal Motor Vehicle Safety Standards

The Bidder and (if selected) Contractor shall submit (1) manufacturer's FMVSS self-certification sticker information that the vehicle complies with relevant FMVSS or (2) manufacturer's certified statement that the contracted buses will not be subject to FMVSS regulations.

Company Name

Type or Print Name of Authorized Person and Title

Signature of Authorized Person

Date

CER 3. Other Forms and Certifications

CER 3.1 Statement of Acceptance of Indemnification/Insurance Requirements

FOR: **Two (2) 40' Low Floor Regular All-Electric Fixed Route Bus**

The Proposer shall sign below that the Proposer accepts in whole the Indemnification and Insurance Requirements set forth in these Specifications. If the Proposer takes exception to some portions, those portions shall be listed here below and the Proposer shall sign that the Proposer accepts all portions of the requirements not listed.

Note: Any exceptions may render the bid non-responsive.

- ACCEPT**
- DO NOT ACCEPT**

If "DO NOT ACCEPT" is checked, please list exceptions:

(INSERT IF APPLICABLE) _____

Type or Print Name of Authorized Person and Title

Signature of Authorized Person

Date

BIDDER'S NAME: _____
(Submit with Bid Proposal)

**CITY OF FRESNO
FINANCE DEPARTMENT
ACCOUNTS PAYABLE SECTION**

CER 3.2 Bid Form

Bidder shall complete the following form and include it in the price Bid.

BID

By execution below by a duly authorized representative(s) of the Bidder, the Bidder hereby offers to furnish equipment and services as specified in its Bid submitted to **City of Fresno** in response to Requirements Contract No. **3604** in its entirety.

Company Name

Business Address

City State Zip Code

Company Name

Type or Print Name of Authorized Person and Title

Type or Print Name of Authorized Person and Title

Phone

Signature of Authorized Person Date

Signature of Authorized Person Date

BIDDER'S NAME: _____
(Submit with Bid Proposal)

CER 3.3 Bid Deposit

Accompanying this bid is a Bid Deposit in the amount of **FIFTEEN-THOUSAND DOLLARS (\$15,000)** in form of:

- | | |
|---|---|
| <input type="checkbox"/> Certified Check | <input type="checkbox"/> Bidder's Bond |
| <input type="checkbox"/> Cashier's Check | <input type="checkbox"/> Irrevocable Letter of Credit |
| <input type="checkbox"/> Certificate of Deposit | <input type="checkbox"/> Annual Bidder's Bond |

Note: Company Checks are NOT acceptable

which is deposited by the undersigned Bidder with the City of Fresno as a guarantee that the Proposer, if awarded all or part of the Contract, will, within 10 working days from the date the Notice of Award is mailed to the Proposer, execute and return a Contract furnished by the City. If the Deposit is in the form of an Annual Bidder's Bond, the bond must be heretofore registered with the Purchasing Manager and must be in the amount of **FIFTEEN-THOUSAND DOLLARS (\$15,000)** in the following form:

Such Deposit is made with the understanding that failure to execute such Contract will result in damage to the City, that the amount of such damage would be difficult to determine and that in the event of such default said Deposit shall become the property of the City; or, if a Bidder's Bond is deposited, the amount of the obligation thereof, but not more than the above stated amount, shall thereupon be due and payable to the City of Fresno as liquidated damages for such default, payment of said amount to be the joint and several obligation of the Bidder and the corporate surety.

Business Location

- The undersigned Proposer does not maintain a place of business in the City of Fresno.
- The undersigned Proposer maintains a place of business in the City of Fresno at:
_____ Fresno, CA _____.

Business License

- The undersigned Proposer has a current City of Fresno Business License and the number is
_____.

If the successful bidder does not have a City of Fresno Business License, he/she shall obtain such a license prior to the issuance of a Notice to Proceed for the Work and maintain in effect throughout the term of this Contract.

CER 3.4 Additional Information to be Provided by Proposer

Proposers must present evidence, satisfactory to the City, indicative of the Proposer's ability to provide the required services and the Proposer's long term financial strength. To this end, the Proposer must attach the following information to the Bid Form:

A. MANUFACTURER'S CERTIFICATION:

If the Proposer is other than the manufacturer, Proposer shall attach:

1. _____ Certification from the manufacturer(s) on manufacturer's letterhead stating that the Proposer is an authorized representative of the manufacturer to sell and lease the manufacturer's ___ and that all equipment is new; and
2. Certification from the manufacturer(s) on manufacturer's letterhead stating that the Proposer is authorized to repair and maintain the manufacturer's equipment; and
3. Documentation that the Proposer's technicians are factory trained and certified; and
4. Either of the following: (1) a letter of commitment from the manufacturer which will assure the Proposer of a source of supply sufficient to satisfy the City's requirements for the contract period including the option years; or (2) other evidence that the Proposer will have an uninterrupted source of supply from which to satisfy the City's requirements for the contract period.

B. TECHNICAL LITERATURE:

The proposer shall include with the bid detailed descriptive literature for the equipment being offered listed herein. Such literature must provide information on electrical wiring needs, space requirements, and all technical data required for a full evaluation. If technical literature provided is not sufficient for the City to evaluate the bid, the City may be request additional information.

CER 3.7 Signature Page

By my signature on this Bid I certify, under penalty of perjury, that the foregoing statements, section 9 and 10, and those contained herein are true and correct.

BID SUBMITTED BY:

(Please follow the instructions for each line, as explained below.)

(1) _____ (____) _____ - _____ (____) _____ - _____
Bidding Firm Phone Fax

(2) _____
(Corp) (Individual) (Partner) (Other)

(3) _____
Business Address

City State Zip Code

(4) By: _____
Signature of Authorized Person

Type or Print Name of Authorized Person and Title

Federal Tax I.D. No.: _____ Date: _____

CER 3.8 Instructions for Signature Page

LINE (1): The name of the Bidder must be the same as that under which a license is issued, if a license is required. If the Bidder is a corporation, enter the exact name of the corporation under which it is incorporated; if Bidder is an individual, enter name; if Bidder is an individual operating under a trade name, enter name and dba (trade name in full); if a partnership, enter the correct trade style of the partnership; if a joint venture, enter exact names of entities joining in the venture.

LINE (2): Identify here the character of the name shown under (1), i.e., corporation (including state of incorporation), individual, partnership, or joint venture.

LINE (3): Enter the address to which all communications and notices regarding the Bid and any Contract awarded thereunder are to be addressed.

LINE (4):
(a) If the Bidder is a corporation, the Bid must be signed by an officer or employee authorized to sign Contracts on behalf of the corporation evidenced by inclusion of one of the following certified by the secretary of the corporation, authorizing the officer or employee to sign contracts (sample certification attached): a copy of the Articles of Incorporation, a copy of the Bylaws, a copy of the Board Resolution or Minutes authorizing the officer or employee to sign Contracts.

BIDDER'S NAME: _____
(Submit with Bid Proposal)

- (b) If Bidder is an individual, he/she must sign the Bid, or if the Bid is signed by an employee or agent on behalf of the Bidder, a copy of a power of attorney must be on file with the City of Fresno prior to the time set for the opening of the bids or must be submitted with the Bid.
- (c) If the Bidder is a partnership, the Bid must be signed by all general partners; or by a general partner(s) authorized to sign Contracts on behalf of the partnership evidenced by inclusion of either a copy of the Partnership Agreement or a recorded Statement of Partnership.
- (d) If the Bidder is a joint venture, the Bid must be signed by all joint venturers; or by a joint venturer(s) authorized to sign Contracts on behalf of the joint venture evidenced by inclusion of either a copy of the Joint Venture Agreement or a recorded Statement of Joint Venture; and if the joint venturer(s) is a corporation or a partnership signing on behalf of the Joint Venture, then Paragraphs (a) and c) above apply respectively.
- (e) Where Bidder is a partnership or a corporation, the names of all other general partners, or the names of the president and secretary of the corporation, and their business addresses must be typewritten below:

NAME	ADDRESS
_____	_____
_____	_____
_____	_____

NOTE: All addresses must be complete with street number, City, State and Zip Code.

BIDDER'S NAME: _____
(Submit with Bid Proposal)

CER 3.9 Authorization Agreement for Direct Payments (ACH Credits)

Company Name _____ Contact Email Address _____
(Required)

Contract Name _____ Telephone Number _____

The City of Fresno, Finance Department, (FINANCE DEPARTMENT), is authorized to initiate credit entries to the company above, (COMPANY), in the account below at the depository financial institution named below, (DEPOSITORY), and to credit the same to such account. Company acknowledges that the origination of ACH transactions to its account must comply with the provisions of U.S. law.

Depository Name _____ Branch _____

City _____ State _____ Zip Code _____

Routing Number _____ Account Number _____

ACH Authorization Agreement Form already on file with City.

This authorization is to remain in full force and effect until FINANCE DEPARTMENT has received written notification of its termination. The FINANCE DEPARTMENT and DEPOSITORY have a reasonable time to process the termination.

Type or Print Name of Authorized Person and Title

Signature of Authorized Person Date

BIDDER'S NAME: _____
(Submit with Bid Proposal)

CER 3.10 Sample Certification

I, _____, certify that I am the secretary of the corporation named
Name

herein; that _____ who signed this Bid on behalf of
Name

the corporation, was then _____ of said corporation; that said
Title

Bid is within the scope of its corporate powers and was duly signed for and on behalf of said corporation by authority of its governing body, as evidenced by the attached true and correct copy of

the _____.
Name of Corporate Document

Type or Print Name of Authorized Person and Title (Secretary)

Signature of Authorized Person Date

CER 3.11 Sample Service Contract

THIS CONTRACT is made and entered into by and between the CITY OF FRESNO, a California municipal corporation, hereinafter called the "City," and [Contractor Name], [Legal Identity], hereinafter called the "Contractor," as follows:

Contract Documents

The "Notice Inviting Bids," "Instructions to Bidders," "Bid," and the "Specifications" including "General Conditions", "Special Conditions" and "Technical Specifications" for the following: [Title] (Bid File No. 9321) [Alternates (if any)] copies of which are annexed hereto, together with all the drawings, plans, and documents specifically referred to in said annexed documents, and are hereby incorporated into and made a part of this Contract, and shall be known as the Contract Documents.

Price

For the estimated monetary consideration of [WRITTEN \$ AMOUNT] DOLLARS AND [WRITTEN CENTS AMOUNT] CENTS (\$[DOLLAR AMOUNT]), as set forth in the Bid and Procurement Document the Contractor shall furnish or cause to be furnished, in a new and working condition, and to the satisfaction of City, and in strict accordance with the Specifications, all of the items as set forth in the Contract Documents.

Payment

The City accepts Contractor's Bid as stated and agrees to pay the consideration stated, at the times, in the amounts, and under the conditions specified in the Contract Documents. Contractor agrees to accept electronic payment from the City.

Indemnification

To the furthest extent allowed by law, including California Civil Code section 2782 (if applicable), Contractor shall indemnify, hold harmless and defend City and each of its officers, officials, employees, agents and volunteers from any and all loss, liability, fines, penalties, forfeitures, costs and damages (whether in contract, tort or strict liability, including, but not limited to personal injury, death at any time and property damage) incurred by City, Contractor or any other person, and from any and all claims, demands and actions in law or equity (including attorney's fees and litigation expenses), arising or alleged to have arisen directly or indirectly out of performance of this Contract. Contractor's obligations under the preceding sentence shall apply regardless of whether City or any of its officers, officials, employees, agents or volunteers are passively negligent, but shall not apply to any loss, liability, fines, penalties, forfeitures, costs or damages caused by the active or sole negligence, or by the willful misconduct, of City or any of its officers, officials, employees, agents or volunteers.

If Contractor should subcontract all or any portion of the work to be performed under this Contract, Contractor shall require each subcontractor to indemnify, hold harmless and defend City and each of its officers, officials, employees, agents and volunteers in accordance with the terms of the preceding paragraph.

This section shall survive termination or expiration of this Contract.

////

////

////

BIDDER'S NAME: _____
(Submit with Bid Proposal)

IN WITNESS WHEREOF, the parties have executed this Contract on the day and year here below written, of which the date of execution by City shall be subsequent to that of Contractor's, and this Contract shall be binding and effective upon execution by both parties.

[Contractor Name],
[Legal Identity]

By: _____

Name: _____
(Type or print written signature.)

Title: _____

Dated: _____

By: _____

Name: _____
(Type or print written signature.)

Title: _____

Dated: _____

CITY OF FRESNO,
a California Municipal Corporation

By: _____

Name: _____
(Type or print written signature.)

Purchasing Manager
Finance Department

Dated: _____

ATTEST:
YVONNE SPENCE, CMC
City Clerk

By: _____
Deputy

Dated: _____

APPROVED AS TO FORM:
DOUGLAS T. SLOAN
City Attorney

By: _____
Deputy/Senior Deputy

Dated: _____

City address:
City of Fresno
Attention: [Name], [Title]
[Street Address]
Fresno, CA [Zip]

CER 4. Vehicle Technical Information

NOTE: This is a sample form to be used by Contractor.

This form must be completed for each proposed bus by Contractor and included in the Technical Bid.

GENERAL COACH DATA SHEET

insert bus type

Bus manufacturer:	
Bus model:	
Understructure manufacturer:	
Model number:	

Basic Body Construction

Type:	
-------	--

Tubing or frame member thickness and dimensions

Over structure	
Understructure	

Skin thickness and material

Roof	
Sidewall	
Skirt panel	
Front end	
Rear end	

Dimensions

Overall length	Over bumpers	<input type="text"/>	ft.	<input type="text"/>	in.
	Over body	<input type="text"/>	ft.	<input type="text"/>	in.
Overall width	Over body excluding mirrors	<input type="text"/>	ft.	<input type="text"/>	in.
	Over body including mirrors—driving position	<input type="text"/>	ft.	<input type="text"/>	in.
	Over tires front axles	<input type="text"/>	ft.	<input type="text"/>	in.
	Over tires center axle	<input type="text"/>	ft.	<input type="text"/>	in.
	Over tires rear axles	<input type="text"/>	ft.	<input type="text"/>	in.
Overall height (maximum)		<input type="text"/>	ft.	<input type="text"/>	in.
	Overall height (main roof line)	<input type="text"/>	ft.	<input type="text"/>	in.

Angle of approach deg.
 Breakover angle deg.
 Breakover angle (rear) deg.
 Angle of departure deg.

Doorway Dimensions

	Front	Rear
Width between door posts	<input type="text"/> in.	<input type="text"/> in.
Door width between panels	<input type="text"/> in.	<input type="text"/> in.
Clear door width	<input type="text"/> in.	<input type="text"/> in.
Doorway height	<input type="text"/> in.	<input type="text"/> in.
Knuckle clearance	<input type="text"/> in.	<input type="text"/> in.

Step height from ground measured at center of doorway

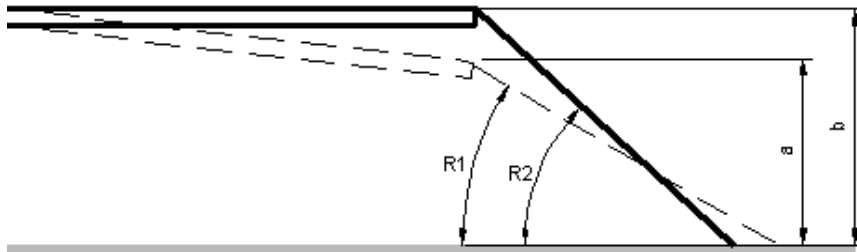

	Front doorway, empty	Ramp angle	Rear Doorway, empty
Kneeled	a. <input type="text"/> in.	R1 <input type="text"/> deg.	a. <input type="text"/> in.
Unkneeled	b. <input type="text"/> in.	R2 <input type="text"/> deg.	b. <input type="text"/> in.

Interior head room (center of aisle)

Front axle location in.
 Center axle location in.
 Rear axle location in.

Aisle width between transverse seats in.

Floor height above ground (centerline of bus)

At front door in.
 At front axle in.
 At drive axle in.
 At rear door in.

Minimum ground clearance (between bus and ground, with bus unkneeled)

Excluding axles in.
 Including axles in.

Horizontal turning envelope (see diagram below)

Outside body turning radius, TR0 (including bumper)
 Front inner corner radius, TR1
 Front wheel inner turning radius, TR2
 Front wheel outer turning radius, TR3
 Inside Body Turning Radius innermost point, TR4 (including bumper)

<input type="text"/>	ft.	<input type="text"/>	in.
<input type="text"/>	ft.	<input type="text"/>	in.
<input type="text"/>	ft.	<input type="text"/>	in.
<input type="text"/>	ft.	<input type="text"/>	in.
<input type="text"/>	ft.	<input type="text"/>	in.

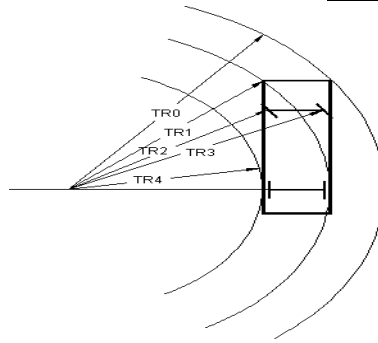

Wheel base

Front in.
 Rear in.

Overhang, centerline of axle over bumper

Front in.
 Rear in.

Floor

Interior length ft. in.
 Interior width (excluding coving) ft. in.
 Total standee area (approximately) ft²
 Minimum distance between wheelhouses:
 Front in.
 Rear in.
 Center in.
 Maximum interior floor slope (from horizontal) deg.

Passenger capacity provided

Total maximum seating
 Standee capacity
 Minimum hip to knee room in.
 Minimum foot room in.

Weight

	No. of people	Front axle			Center axle			Rear axle			Total bus
		Left	Right	Total	Left	Right	Total	Left	Right	Total	
Empty bus, full	<input type="text"/>	<input type="text"/>	<input type="text"/>	<input type="text"/>	<input type="text"/>	<input type="text"/>	<input type="text"/>	<input type="text"/>	<input type="text"/>	<input type="text"/>	<input type="text"/>

farebox											
Fully seated, full farebox											
Fully loaded standee and fully seated, full farebox											
Crush load (1.5x fully loaded)											
GVWR											
GAWR											

Propulsion System, main

Manufacturer				
Type and weight rating				
Model number				
Net SAE horsepower		hp at		RPM
Net SAE torque		lb./ft. at		RPM
Maximum speed, no load		RPM		
Maximum speed, full load		RPM		

Voltage regulator

Manufacturer	
Model	

Voltage equalizer

Manufacturer	
Model	

Alternator

Manufacturer			
Type			
Model			
Output at idle		amps	
Output at maximum speed		amps	
Maximum warranted speed		rpm	
Speed at idle (approximately)		rpm	
Drive type			

Air compressor

Manufacturer		
Type		
Rated capacity		CFM
Capacity at idle (approximately)		CFMs

Capacity at maximum speed (engine)	<input type="text"/>	CFM
Maximum warranted speed	<input type="text"/>	rpm
Speed idle	<input type="text"/>	rpm
Drive type	<input type="text"/>	
Governor:		
Cut-in pressure	<input type="text"/>	psi
Cut-out pressure	<input type="text"/>	psi

Axles

First

Manufacturer	<input type="text"/>	
Type	<input type="text"/>	
Model number	<input type="text"/>	
Gross axle weight rating	<input type="text"/>	lbs.
Axle load	<input type="text"/>	lbs.

Second

Manufacturer	<input type="text"/>	
Type	<input type="text"/>	
Model number	<input type="text"/>	
Gross axle weight rating	<input type="text"/>	lbs.
Axle load	<input type="text"/>	lbs.

Third

Manufacturer	<input type="text"/>	
Type	<input type="text"/>	
Model number	<input type="text"/>	
Gross axle weight rating	<input type="text"/>	lbs.
Axle load	<input type="text"/>	lbs.
Axle ratio	<input type="text"/>	

Suspension system

Manufacturer	<input type="text"/>		
Type:	First:	<input type="text"/>	
	Second:	<input type="text"/>	
	Third:	<input type="text"/>	
Springs:	First:	<input type="text"/>	
	Second:	<input type="text"/>	
	Third:	<input type="text"/>	

Joint

Manufacturer	<input type="text"/>	
Type	<input type="text"/>	
Model number	<input type="text"/>	

Wheels and tires

Wheels

Make	
Size	
Capacity	
Material	

Tires

Manufacturer		
Type		
Size		
Load range/air pressure		psi

Steering, power

Pump

Manufacturer and model number		
Type		
Relief pressure		psi

Booster/gear box

Manufacturer and model number		
Type		
Ratio		

Power steering fluid capacity		gal
Maximum effort at steering wheel		lbs. (unloaded stationary coach on dry asphalt pavement)
Steering wheel diameter		in.

Brakes

Make of fundamental brake system			
Brake chambers vendor size and part number:	First:		
	Second:		
	Third:		
Brake operation effort			

Slack adjuster's vendor's type and part numbers

First:	Right:	
	Left:	
Second:	Right:	
	Left:	
Third:	Right:	
	Left:	
Length:	First take-up:	
	Second take-up:	

Third take-up:

Brake drums/discs

First:	Manufacturer	<input type="text"/>	
	Part number	<input type="text"/>	
	Diameter	<input type="text"/>	in.
Second:	Manufacturer	<input type="text"/>	
	Part number	<input type="text"/>	
	Diameter	<input type="text"/>	in.
Third:	Manufacturer	<input type="text"/>	
	Part number	<input type="text"/>	
	Diameter	<input type="text"/>	in.

Brake lining manufacturer	<input type="text"/>
Type	<input type="text"/>

Brake lining identification

First:	Forward	<input type="text"/>
	Reverse	<input type="text"/>
Second:	Forward	<input type="text"/>
	Reverse	<input type="text"/>
Third:	Forward	<input type="text"/>
	Reverse	<input type="text"/>

Brake linings per shoe

First	<input type="text"/>
Second	<input type="text"/>
Third	<input type="text"/>

Brake lining widths

First	<input type="text"/>	in.
Second	<input type="text"/>	in.
Third	<input type="text"/>	in.

Brake lining lengths

First	<input type="text"/>	in.
Second	<input type="text"/>	in.
Third	<input type="text"/>	in.

Brake lining thickness in.

Brake lining per axle

First	<input type="text"/>	sq. in.
-------	----------------------	---------

Second sq. in.
 Third sq. in.

Cooling system

Radiator/charge air cooler

Manufacturer

Type

Model number

Number of tubes

Tubes outer diameter in./ in.

Fins per inch fins

Fin thickness in.

Total cooling and heating system capacity gal

Radiator fan speed control

Surge tank capacity quarts

Engine thermostat temperature setting: Initial opening (fully closed) °F
 Fully open °F

Overheat alarm temperature sending unit setting °F

Shutdown temperature setting °F

Air reservoir capacity

Supply reservoir in.³

Primary reservoir in.³

Secondary reservoir in.³

Packing reservoir in.³

Accessory reservoir in.³

Other reservoir type in.³

Heating, ventilation and air conditioning equipment

Heating system capacity BTU/hr.

Air conditioning capacity BTU

Ventilating capacity CFM

Compressor

Manufacturer

Model

Number of cylinders

Drive ratio

Maximum warranted speed rpm

Operating speed rpm (recommended)

Weight lbs.

Oil capacity Dry gal

Wet gal

Refrigerant: Type lbs.

Condenser

Manufacturer		
Model		
Number of fins/in.		
Outer diameter of tube		in.
Fin thickness		in.

Condenser fan

Manufacturer		
Model		
Fan diameter		in.
Speed maximum		rpm
Flow rate (maximum)		CFM

Receiver

Manufacturer		
Model		
Capacity		lbs.

Condenser fan drive motors

Manufacturer		
Model		
Type		
Horsepower		hp
Operating speed		rpm

Evaporator fan drive motors

Manufacturer		
Model		
Type		
Horsepower		hp
Operating speed		rpm

Evaporator(s)

Manufacturer		
Model		
Number of rows		
Number of fins/in.		
Outer diameter of tube		in.
Fin thickness		in.
Number of evaporators		

Expansion valve

Manufacturer	
Model	

Filter-drier

Manufacturer	
Model	

Heater cores

Manufacturer		
Model		
Capacity		Btu/hr.
Number of rows		
Number of fins/in.		
Outer diameter of tube		in.
Fin thickness		in.
Number of heater cores		

Floor heater blowers

Front	
Rear	

Controls

Manufacturer	
Model	

Operator's heater

Manufacturer		
Model		
Capacity		Btu/hr.

Ventilation system

Type	
------	--

Coolant heater

Make		
Model		
Capacity		Btu

Interior Lighting

Manufacturer		
Type		
Number of fixtures		

Size of fixtures	
Power pack	

Doors

Front

Manufacturer of operating equipment	
Type of door	
Type of operating equipment	

Rear

Manufacturer of operating equipment	
Type of door	
Type of operating equipment	

Passenger windows

Front

Manufacturer			
Model			
Type			
Number:	Side		
	Rear		
Sizes:			
Glazing:	Type		
	Thickness		
	Color of tint		
	Light transmission		

Mirrors

	Size	Type	Manufacturer	Part no.	Model no.
Right side exterior					
Left side exterior					
Center rearview					
Front entrance area					
Upper-right corner					
Rear exit area					

Seats

Passenger

Manufacturer	
Model	
Type	

Operator

Manufacturer	
Model and part number	
Type	

Paint

Manufacturer	
Type	

Wheelchair ramp equipment

Manufacturer		
Model number		
Capacity		lbs.
Width of platform		in.
Length of platform		in.
System fluid capacity		quarts
Type of fluid used		
Operating hydraulic pressure		psi
Hydraulic cylinders:	Size	
	Number	

Wheelchair securement equipment

Manufacturer	
Model number	

Destination signs

Manufacturer	
Type	

Character length

Front destination		in.
Front route		in.
Curbside destination		in.
Rear route		in.

Character height

Front destination		in.
Front route		in.
Curbside destination		in.
Rear route		in.

Number of characters

Front destination	
Front route	
Curbside destination	
Rear route	

Message width

Front destination		in.
Front route		in.
Curbside destination		in.
Rear route		in.

Electrical

Multiplex system

Manufacturer	
Model number	

Batteries

Manufacturer	
Model number	
Type	

Communication system

GPS

Manufacturer	
Model number	

PA system

	Manufacturer	Model number	Number
Amplifier			
Microphone			
Internal speakers			
External speaker			

Energy storage

Type		
Number of cells		V
Battery pack voltage		V
Weight		lbs.

Security camera system

Manufacturer		
Model number		
Number of cameras		

Storage capacity

Bike racks

Manufacturer
 Model number

Fire detection system

Manufacturer
 Model number
 Fire detectors
 Type (thermal or optical)
 Number of detectors

Automatic voice annunciator system

Manufacturer
 Model and part number

Annunciator LED sign

Number of signs
 Housing dimensions
 Character length in.
 Character height in.
 Character width in.

GPS antenna

Manufacturer
 Model and part number

Automatic passenger counter

Manufacturer
 Model and part number a.
 b.
 c.
 Sensor type

Real-time bus arrival prediction system

	Manufacturer	Model number
Router	<input type="text"/>	<input type="text"/>
Cellular modem	<input type="text"/>	<input type="text"/>
Charge protection	<input type="text"/>	<input type="text"/>

Electronic tire pressure monitoring system

Manufacturer

BIDDER'S NAME: _____
(Submit with Bid Proposal)

Model number

Electronic brake stroke/wear indicator system

Manufacturer

Model number

NOTE: All information above is accurate to the timeframe upon submission. The City reserves the right to update above data if changes occur, upon consultation with the customer.

Appendix B: Software Escrow Agreement

ESCROW AGREEMENT

THIS AGREEMENT ("Escrow Agreement") is made and entered into as of _____ day of _____, 2018 by and among [insert name of Contractor], a **California** corporation ("Licensor"), **City of Fresno** ("Licensee"), and _____, national banking association, as escrow agent ("Escrow Agent").

WHEREAS, Licensor and Licensee have entered into an agreement pursuant to which Licensor has licensed to Licensee the use of specified computer programs and related materials, being described with particularity therein (the "License Agreement"), which License Agreement is attached hereto as Exhibit "C"; and

WHEREAS, the Escrow Agent can provide third-party software escrow protection by storing, retaining and allowing limited access to proprietary computer software, related media and materials.

NOW, THEREFORE, in consideration of the promises and mutual covenants contained herein and for other good and valuable consideration, receipt of which is hereby acknowledged, the parties hereby agree as follows:

1. DEPOSIT OF DOCUMENTATION

- (a) The term "Documentation" as used in this Escrow Agreement means the computer source code for the application software magnetic media provided pursuant to the License Agreement (the "System Software") owned by Licensor and, in turn, licensed to Licensee, and such other related technical documentation and materials as shown in Exhibit "D".
- (b) _____ Licensor agrees to deposit with the Escrow Agent a complete copy of the Documentation as provided in Exhibit "D" on or before _____, 2015_.
- (c) As Licensor creates new releases of the System Software or any part thereof, Licensor shall promptly deposit one copy of each of the Documentation applicable thereto in escrow with the Escrow Agent. Concurrently with each such deposit, Licensor shall deliver to the Escrow Agent and Licensee a revised Exhibit "D", and shall deliver to Licensee a certificate in the form attached hereto as Exhibit "E". Licensor shall maintain in escrow the latest field-supported releases of the Documentation or the last emergency maintenance release, whichever is most current; provided, however, all Documentation deposited in the escrow account pursuant to this Escrow Agreement shall remain in escrow so long as Licensor is obligated under the License Agreement to provide the System Software to Licensee.
- (d) All copies of source codes delivered hereunder shall be clearly marked, both on the sealed container in which the magnetic media comprising such copies are contained and on the magnetic media themselves, to indicate the Documentation and the version thereof represented by such copies.

2. STORAGE AND SECURITY

- (a) The Escrow Agent shall act as custodian of the Documentation until this escrow is terminated pursuant to Section 3 of this Escrow Agreement. The Escrow Agent shall establish, under its control, a secure receptacle for the purpose of storing the Documentation. The Escrow Agent shall exercise reasonable care to keep the Documentation protected from electric or magnetic current that could damage the Documentation, and shall provide the same degree of care of the Documentation as it maintains for its software including without limitation source code and valuable documents and those of clients stored in the same location; provided, however, that the Escrow Agent shall have no liability with respect to any damage to the Documentation unless such damage is the result of the fault of the Escrow Agent.
- (b) The Documentation deposited with the Escrow Agent by Licensor pursuant to this Escrow Agreement shall remain the exclusive property of the Licensor, except as otherwise provided herein.
- (c) Except as provided in this Escrow Agreement or the attached Exhibits or as required by applicable law, the Escrow Agent agrees that:
 - (1) The Escrow Agent shall not divulge, disclose or otherwise make available to any person other than Licensor, or make any use whatsoever of the Documentation except in accordance with this Escrow Agreement;
 - (2) The Escrow Agent shall not permit any person access to the Documentation, except as may be necessary for the Escrow Agent's authorized representatives to perform its function under this Escrow Agreement; and
 - (3) Access to the Documentation by Licensor shall be granted by the Escrow Agent only to those persons duly authorized in writing by a competent officer of Licensor.
- (d) The Escrow Agent shall have no obligation or responsibility to verify or determine that the Documentation deposited with the Escrow Agent by Licensor does, in fact, consist of those items which Licensor is obligated to deliver under this or any other agreement, and the Escrow Agent shall bear no responsibility whatsoever to determine the existence, relevance, completeness, currency or accuracy of the Documentation at any time.
- (e) The Escrow Agent's sole responsibility shall be to accept, store, protect and deliver the Documentation deposited with the Escrow Agent by Licensor in accordance with the terms and conditions of this Escrow Agreement.
- (f) If the Escrow Agent should at any time be confronted with inconsistent claims or demands by the other parties to this Escrow Agreement, then, subject to the provisions of Section 8, it shall have the right to interplead the parties in any court of competent jurisdiction and request that the court determine the respective rights of the parties with respect to this Escrow Agreement and the Documentation and, upon doing so, the Escrow Agent automatically shall be released from any obligation or liability as a consequence of any such claims or demands.

3. RELEASE FROM ESCROW

- (a) The Escrow Agent shall release the Documentation (or any designated part thereof) at any time in accordance with a written notice signed by both Licensor and Licensee and specifying the particular item or items of Documentation to be released and the party to whom release shall be made.
- (b) The Escrow Agent shall release the Documentation 16 (sixteen) days following receipt of a notice from Licensee (the "Licensee Notice") given in accordance with Section 10 hereof, unless

the Escrow Agent receives a counter-notice in accordance with Section 3(c) hereof, given in accordance with Section 10 hereof. The Licensee Notice shall state that a Licensee Release Condition, as hereinafter defined, has occurred and shall state with particularity the nature of such Licensee Release Condition. The Licensee Notice shall be given to Licensor in accordance with Section 10 hereof at the same time and by the same means that it is transmitted to the Escrow Agent, and proof of such transmission shall be submitted to the Escrow Agent along with the Licensee Notice. A "Licensee Release Condition" shall mean: (1) any material breach by Licensor of any material term or condition of the License Agreement, if such material breach has not been cured within the 30 (thirty) day period following Licensor's receipt of written notice thereof pursuant to the License Agreement; or (2) Licensor fails to support the System Software licensed to Licensee as required by the License Agreement; or (3) Licensor fails to fulfill its warranty obligations pursuant to the License Agreement.

- (c) If Licensor disputes the existence of a Licensee Release Condition, Licensor shall give to Licensee and the Escrow Agent a counter-notice in accordance with Section 10 hereof, within 15 (fifteen) days of the date on which the Licensee Notice was given to the Escrow Agent and Licensor.
- (d) If the Escrow Agent is given a counter-notice under Section 3(c) hereof, it shall not release the requested item or items of the Documentation until and unless it receives an order and instruction, in writing, signed either by representatives of both Licensee and Licensor, or by an arbitrator as provided in Section 8 hereof.

Any receipt of the Documentation (or any designated part thereof) by Licensee pursuant to this Section 3 shall be subject to the terms and conditions of the License Agreement, such that Licensee shall accord the same security and protection to the Documentation or any part as it is obligated to give to the System Software.

The Escrow Agent shall release to Licensor all Documentation held by it upon termination of the License Agreement pursuant to clause (2) of the first sentence of Section 4 or, if that day is not a business day, on the next succeeding business day.

4. TERMINATION

- (a) This Escrow Agreement shall terminate upon the earlier of: (1) the release by the Escrow Agent of all the Documentation pursuant to the terms of this Agreement; or (2) (month/day/year) (or if the Escrow Agent receives documentation satisfactory to it to the effect that the term of the License Agreement has been extended pursuant to the provisions thereof, then such date as is 180 (one hundred eighty) days following the expiration date of the term of the License Agreement, as extended from time to time). No party shall have any liability hereunder (except pursuant to Section 2(c)) for acts or omissions occurring after termination of this Escrow Agreement. Upon such termination, the Escrow Agent shall return the Documentation then in escrow to Licensor after the payment of all costs, fees and expenses due to the Escrow Agent, including fees and expenses of its agents and attorneys.
- (b) Licensee and Licensor may terminate this Escrow Agreement by mutual written agreement upon 15 (fifteen) days' advance written notice to the Escrow Agent.
- (c) This Escrow Agreement cannot be changed or terminated orally and may be changed only with the prior written consent of all of the parties hereto. This Escrow Agreement is not intended to modify or supersede any of the arrangements of Licensor and Licensee as set forth in the License Agreement.
- (d) The Escrow Agent may resign as escrow agent at any time upon 30 (thirty) days' notice to

Licensor and Licensee, but only if a successor escrow agent has been appointed prior to the effective date of the Escrow Agent's resignation. Upon receipt of notice of resignation, Licensor and Licensee promptly shall use their best efforts to designate a successor escrow agent to serve in accordance with the terms of this Agreement. If a successor escrow agent has not been appointed within a 60 (sixty) day period, the Escrow Agent may apply to a court of competent jurisdiction to have a successor appointed. Upon receipt of an affidavit signed by an officer of Licensor and an officer of Licensee directing the disposition of the Documentation to a successor escrow agent, the Escrow Agent shall promptly comply with that affidavit.

5. INDEMNIFICATION

The Escrow Agent shall not be liable to any party under this Escrow Agreement in connection with the performance of its duties hereunder, except for liability resulting from the Escrow Agent's fault. Licensor and Licensee shall, jointly and severally, indemnify and hold the Escrow Agent harmless against any loss, damage, or expense, including legal fees, that it may incur to anyone as a result of acting as escrow agent under this Agreement, except for any loss, liability, damage or expense arising from the Escrow Agent's fault. If Licensor or Licensee makes any payment (an "Indemnification Payment") to the Escrow Agent pursuant to the provisions of the preceding sentence, then the party making the Indemnification Payment (the "Paying Party") shall be entitled to contribution from the other (the "Contributing Party") in an amount such that following contribution by the Contributing Party, the Paying Party and the Contributing Party shall each bear the portion of the Indemnification Payment as is proportionate to the relative fault of each of them with respect to the event that gave rise to the Indemnification Payment; provided, however, that if neither the Paying Party nor the Contributing Party is at fault, the Paying Party shall be entitled to contribution from the Contributing Party in an amount equal to one-half of the Indemnification Payment. The provisions of the preceding sentence shall not in any way limit the liability of Licensor or Licensee to the Escrow Agent pursuant to the second sentence of this Section 5 or any other provision of this Agreement.

6. GOOD FAITH RELIANCE

The Escrow Agent may rely and act upon written instructions, instruments or signatures believed by the Escrow Agent in good faith to be genuine and may assume that any person purporting to give any written notice, respect, advice, or instruction in connection with or relating to this Escrow Agreement has been duly authorized to do so. The Escrow Agent's duties shall be determined with respect to this Agreement and applicable laws only, and the Escrow Agent is not charged with knowledge of or duties under any other document, including the License Agreement.

7. FEES

- (a) In consideration of performing its functions as Escrow Agent, the Escrow Agent shall be compensated as set forth on Exhibit "F". The fees set forth on Exhibit "F" will be billed periodically by the Escrow Agent to:

- (b) The fees set forth in Exhibit "F", are for ordinary services as escrow holder. In the event the Escrow Agent is required to incur any additional or extraordinary legal fees as a result of being escrow holder, including intervention in any litigation or proceeding, the Escrow Agent shall receive full compensation for any such reasonable legal fees that are documented to the Licensor and/or Licensee's satisfaction.

8. DISPUTES

The parties shall attempt to resolve any dispute or controversy between Licensor and Licensee regarding the release of the Documentation by non-binding mediation in the *City of Fresno, CA*.

Licensor and Licensee shall jointly select a mediator within 10 (ten) days following the giving of a counter-notice under Section 3(c) hereof. Any mediation pursuant to this Section 8 shall be conducted on an expedited basis. Licensor and Licensee shall use their respective best efforts to conclude such mediation within 45 (forty-five) days from the date a mediator is elected pursuant to this Section 8. In the event mediation is not successful, parties may pursue litigation. The venue for such litigation shall be the County of Fresno, CA, and California law shall govern.

9. ENTIRE AGREEMENT

This Escrow Agreement, including Exhibits "D", "E" and "F" hereto, constitutes the entire agreement among the parties concerning the subject matter hereof and shall supersede all previous communications, representations, understandings and agreements, either oral or written among the parties. This Escrow Agreement is intended to be and shall be treated as an agreement separate and distinct from the License Agreement.

10. NOTICE

All notices required or permitted by this Escrow Agreement shall be sufficiently served by mailing the same by certified or registered mail, return receipt requested, to the parties at their respective addresses, as follows:

(a) Escrow Agent:

Attn: _____

Ref: _____

(b) Licensor:

Attn: _____

(c) Licensee:

Attn: _____

11. COUNTERPARTS

This Escrow Agreement may be executed in one or more counterparts, each of which shall be deemed an original, and all of which taken together shall constitute one and the same instrument.

12. GOVERNING LAW

This Escrow Agreement shall be governed by and construed in accordance with the laws of the State of California, without regard to its choice-of-laws or conflicts-of-law provisions.

13. SEVERABILITY

In the event any of the provisions of this Escrow Agreement shall be held by a court of competent jurisdiction to be contrary to any state or federal law, the remaining provisions of this Escrow Agreement will remain in full force and effect.

14. HEADINGS

The section headings in this Escrow Agreement do not form a part of it, but are for convenience only and shall not limit or affect the meaning of the provisions.

15. MISCELLANEOUS

- (a) If in doubt as to its duties hereunder, Escrow Agent may consult with counsel of its choice.
- (b) Nothing in this Agreement shall impose on the Escrow Agent the duty to qualify to do business or act as fiduciary in any jurisdiction other than

IN WITNESS WHEREOF, the parties have executed this Escrow Agreement on the date first above written.

As Escrow Agent: _____
Name and title

Signature Date

As Licensor: _____
Name and title

Signature Date

As Licensee: _____
Name and title

Signature Date

EXHIBIT "A"
Itemized Pricing

Spare Components and Parts

Training Subject		Hours	Cost per Unit	Total Cost
Standard Bus Maintenance				
1	Introduction	1		
2	Jacking, Lifting, and Towing	2		
3	Depot Charger	2		
4	High Voltage System/Safety	4		
5	Low Voltage System	4		
6	Control System/Diagnostics	8		
7	Propulsion System	1		
8	Suspension	1		
9	Air System	1		
10	Steering	1		
11	Cooling System	2		
12	Preventative Maintenance	3		
13	Intro to Door system	1		
14	Intro to HVAC System	1		
Standard Fast Charging Maintenance				
15	Introduction	1		
16	HV Safety	4		
17	Maintenance Procedures	4		
18	Calibrating Procedure	1		
19	Troubleshooting	2		
20	Fast Charger Components	2		
Standard Other Training				
21	Bus Familiarization and Introduction	16		
22	Using the Depot Charger	2		
23	EMS and First Responder	8		
24	Operator Training	24		
Vendor Training				
25	Door System	16		
26	HVAC	16		
27	Structural Composite Repair	24		
28	Depot Charger Maintenance and Repair	8		
			Total	

Diagnostic Equipment Deliverables

Spare Components And Parts Deliverables		Quantity Due	Cost Per Unit	Total Cost
Low Voltage Electrical Power				
1	Converter, DC-DC	1		
2	Contactor 350 AMP	2		
3	Vanner Battery Equalizer	1		
4	Battery, 12V, 100AH, Group 31	2		
High Voltage Electrical Power				
5	Contactor, GX26,600A, 800 VDC	2		
6	Fuse, 20AMP, 600VAC, FERRAZ SHAWMUT (ATMR20)	2		
7	VFD, Dual 30kw Output	1		
Drivers Work Place				
8	Actuator, Reverse Selection Switch	1		
9	Actuator, Drive Selection Switch	1		
10	Actuator, Neutral Selection Switch	1		
11	Actuator, Front Door Control Switch	1		
12	Actuator, Rear Door Control Switch	1		
15	SWITCH, FLOOR, DIMMER, HEADLAMP	2		
16	Driver Seat Complete w/ Mounting Hardware and Bracket	1		
Wipers and Washers				
18	Wiper Motor, 2 Speed	1		
19	Wiper Arm, Windshield, CS	1		
20	Wiper Arm, Windshield, SS	1		
21	Wiper, Blade	1		
22	Wiper Blade, Windshield, 1000MM	1		
Electrical Cabinet				
23	Relay 10A	2		
24	Relay 35A	2		
Front Suspension And Steering				
25	Spring, Air, Front, 1T19L-5 BELLOW	2		
26	Shock Absorber Front	2		
Rear Suspension				
27	Spring, Air, Rear	2		
28	Shock Absorber Rear	2		
Ride Height				
29	Sensor, Height, Suspension, 6" Arm	2		
Exterior Lighting				
30	Light, Tail Lamp, Rear	2		
31	Light, Back Up Lamp, Rear	2		
32	Light, Rear Turn Signal, Clear Lens, Amber Led	2		
33	Light, Red, Side Marker	4		

BIDDER'S NAME: _____
 (Submit with Bid Proposal)

Spare Components And Parts Deliverables		Quantity Due	Cost Per Unit	Total Cost
34	Light, Yellow, Side Marker	8		
Air System				
35	Modulator, M-32, 24V	2		
36	Valve, Double Check, DC-4	1		
37	Valve, Single Check, SC-3	1		
38	Transducer, Pressure	1		
39	Solenoid, Pneumatic, Exhaust, High Flow, Suspension	2		
Coolant System				
40	Pump, Water, Catalyst	3		
Entrance Doors				
41	Glass, Entrance Door	1		
42	Panel, Assy, Left, Entrance Door	1		
43	Panel Assy, Right, Entrance Door	1		
Exit Doors				
44	Glass, Exit Door	1		
45	Panel Assy, Left, Exit Door	1		
46	Panel Assy, Right, Exit Door	1		
Bus Body				
47	Gas Spring, Lower Side Hatch	3		
48	Gas Spring, Clamshell	3		
49	Gas Spring, Lower Hatch Rear	3		
50	Spring, Gas, 8" Stroke, 20LB	2		
51	Latch, Scoop	1		
52	Latch , Compression, Square Key	1		
Exterior Attachments				
53	Wheel Well Flare, Front	2		
54	Wheel Well Flare, Rear	2		
55	Mirror, CS	2		
56	Mirror, SS	2		
Windows And Windshield				
57	Windshield, Front	1		
58	Rear Window	1		
59	Driver Window	1		
60	Driver Window	1		
61	Gasket, Windshield	1		
Modules				
62	Computer, Central, Multiplex, ZR32-A, 24V	1		
63	Circuit Breaker, Type III, 5A	1		
64	Circuit Breaker, Type III, 10A	1		
65	Circuit Breaker, Type III, 15AMP	1		
66	Circuit Breaker, Type III, 20A	1		

Spare Components And Parts Deliverables		Quantity Due	Cost Per Unit	Total Cost
67	Controller, Node, MUX (Multiplex), MUX2-B, 12V, 24	3		
Consumables				
68	Oil, Compressor, Hydrovane HPO	3		
69	Air Filter, Large, Air Compressor	1		
70	Air Filter, Small, Air Compressor	1		
71	Desiccant, Pack	10		
72	TA366-3056 Desiccator	5		
73	Filter, Air, Defroster	1		
74	Filter, Air, Foam , HVAC	1		
			Total	

Training Deliverables

Tooling and Equipment Deliverables		Quantity Due	Cost per Unit	Total Cost
1	Manufacturer Diagnostic Tool - Main diagnostic tool for bus, lifetime subscription	1		
2	DIAGNOSTIC LAPTOP COMPUTER - Troubleshooting on the bus	1		
	a. Windows 7 based 32 bit operating system			
	b. Intel Core 2 Duo T7300 / 2.0 GHz			
	c. L2 cache - 4.0 MB			
	d. DVD drive			
	e. No web camera			
	f. 2 GB RAM			
	g. 500 GB solid state hard drive			
	h. Bluetooth 2.0 EDR, 802.11a/b/g			
	i. Ethernet			
	j. Trusted Platform Module (TPM 1.2) Security Chip			
3	026024 USB LINK 026025 ADAPTER	1		
4	USB-Link (WiFi) + J1962 Adaptor - Used with the Manufacturer Diagnostic Tool	1		
5	ABS Programming Tool	1		
6	Arc Flash jacket and over pant, AS1200 face shield, hard hat, Salisbury storage bag and safety glasses. (Size S- 3XL)	1		
7	HV Glove Kit (size 8-12)	1		
8	Red Lockout Padlock	2		
9	Grip-Cinching Cable Lockout, Red, 8 ft.	2		
10	Lift Table, Battery	1		
11	Insulated Crimper	1		
12	Deutsch Crimper	1		
13	MUX Crimper	1		
14	Deutsch Pin Removal Tool	1		
15	Plastic fuse puller	1		

BIDDER'S NAME: _____
(Submit with Bid Proposal)

16	Molex Electrical Pin Extractor Tool	1		
17	DELPHI PIN EXTRACTOR	1		
18	DB9/OBD2 adapter - Troubleshooting on the bus or charger	1		
19	Sulzer Mixpac 400mL Manual Cartridge Gun - For minor replacement or repair of bonded components	1		
20	Sulzer Mixpac 400mL Pneumatic Cartridge Gun - For large replacement or repair of bonded components	1		
21	80 PC Master Electricians Insulated Tool Set In Rolling Water Tight Traveling Tool Box.	1		
			Total	



BIDDER'S NAME: _____
(Submit with Bid Proposal)

EXHIBIT "B"

TELEPHONE # (559) 621-1332

FAX # (559) 488-1069

<p>BID QUESTIONS FOR: Two (2) 40' Low Floor Regular All-Electric Fixed Route Bus</p> <p>BID FILE NUMBER: 3604</p> <p>ATTENTION: GARY WATAHIRA, PURCHASING MANAGER</p>	<p>(FOR CITY OF FRESNO USE ONLY)</p> <p>QUESTION NO: _____</p> <p>DATE: _____ REVIEWED BY: _____</p> <p>RESPONSIBLE FOR RESPONSE:</p> <p><input type="checkbox"/> CITY STAFF</p> <p><input type="checkbox"/> CONSULTANT</p>
---	---

<p>FROM: _____</p> <p>COMPANY: _____</p> <p>CONTACT PERSON: _____</p>	<p>DATE: _____</p> <p>PHONE No: _____</p> <p>FAX No: _____</p>
---	--

QUESTION: _____

ANSWER: _____

RESPONSE BY: _____ DATE: _____

INCLUDED IN ADDENDUM NO. _____ DATE: _____

BIDDER'S NAME: _____
(Submit with Bid Proposal)

EXHIBIT "C"

[Insert Form of License Agreement per Introductory paragraph of Escrow Agreement.]

BIDDER'S NAME: _____
(Submit with Bid Proposal)

EXHIBIT "D"
Documentation

EXHIBIT "E"
CERTIFICATE AS TO DEPOSIT OF ADDITIONAL SOURCE CODES

_____ ("Licensor") hereby certifies
to _____ ("Licensee") that Licensor has delivered to Escrow
Agent on _____, 20____, to be held in escrow pursuant to the terms of the
Escrow Agreement dated as of _____, 20____, among Licensor, Licensee and
Escrow Agent, one copy of each of the following Source Codes:

[describe source codes]

Dated: _____, 20__

CONTRACTOR

As Licensee: _____
(Name and Title)

Authorized Signature

Date

BIDDER'S NAME: _____
(Submit with Bid Proposal)

EXHIBIT "F"
FEES

REFERENCES

SAE #	Title	Date Published
J10	Methods of Test for Paints - Part J10: Determination of Deposition Efficiency of Coating Powders	Sep 15, 1998
J211	Instrumentation for Impact Test—Part 2: Photographic Instrumentation	May 1, 2001
J287	Operator Hand Control Reach	Feb 1, 2007
J366	Exterior Sound Level for Heavy Trucks and Buses	Feb 1, 1987
J382	Windshield Defrosting Systems Performance Requirements - Trucks, Buses, and Multipurpose Vehicles.	Jan 1, 1994
J534	Lubrication Fittings	May 1, 2008
J537	Storage Batteries	Sep 1, 2000
J541	Voltage Drop for Starting Motor Circuits	Oct 1, 1996
J587	License Plate Illumination Devices (Rear Registration Plate Illumination Devices)	Sep 1, 2003
J593	Backup Lights (Reversing Lights)	Sep 1, 2005
J673	Automotive Safety Glasses	Oct 1, 2005
J680	Location and Operation of Instruments and Controls in Motor Truck Cabs, Recommended Practice	Sep 1, 1988
J686	Motor Vehicle License Plates	Oct 1, 1999
J689	Curbstone Clearance, Approach, Departure, and Ramp Breakover Angles—Passenger Car and Light Truck	Aug 1, 2009
J833	Human Physical Dimensions	May 1, 2003
J844	Nonmetallic Air Brake System Tubing	Nov 1, 2004
J941	Motor Vehicle Operators' Eye Locations	Mar 1, 2010
J994	Alarm—Backup—Electric Laboratory Performance Testing	Mar 1, 2009
J1050	Describing and Measuring the Operator's Field of View	Jan 1, 2003
J1113	Electromagnetic Compatibility Component Test Procedure Part 42, Conducted Transient Emissions	Oct 1, 2006
J1127	Low Voltage Battery Cable	Mar 1, 2010
J1128	Low Voltage Primary Cable	Dec 1, 2005
J1149	Metallic Air Brake System Tubing and Pipe	Aug 1, 2007
J1292	Automobile and Motor Coach Wiring	Jan 1, 2008
J1455	Recommended Environmental Practices for Electronic Equipment Design in Heavy-Duty Vehicle Applications	Jun 1, 2006
J1587	Joint SAE/TMC Electronic Data Interchange between Microcomputer Systems in Heavy-Duty Vehicle Applications, Recommended Practice	Jan 1, 1996
J1708	Serial Data Communications Between Microcomputer Systems in Heavy-Duty Vehicle Applications	Oct 1, 2008
J1986	Balance Weight and Rim Flange Design Specifications, Test Procedures, and Performance Recommendations	Jan 1, 2006
J1939	Data Link Layer	Dec 1, 2006
J1995	Engine Power Test Code - Spark Ignition and Compression Ignition - Gross Power Rating, Standard;	Jun 1, 1990
J2402	Road Vehicles—Symbols for Controls, Indicators, and Tell-tales	Jan 1, 2010
J2711	Recommended Practice for Measuring Fuel Economy and Emissions of Hybrid-Electric and Conventional Heavy-Duty Vehicles	Sept 1, 2002

ABBREVIATION AND ACRONYMS

A/C	air conditioning
ABS	anti-lock braking system
AC	alternating current
ACQ	alkaline copper quaternary
ADA	Americans with Disabilities Act
Ah	amp hour
ALR	auto-locking retractor
APA	The Engineered Wood Association, formerly the American Plywood Association
APC	automatic passenger counter
APTA	American Public Transportation Association
ASTM	ASTM International, formerly the American Society for Testing and Materials
ATC	automatic traction control
AVL	automatic vehicle location
AWG	American Wire Gauge
BAFO	Best and Final Offer
BMS	Battery Management System
BRT	bus rapid transit
CARB	California Air Resources Board
CCS	climate control system
CCTV	closed-circuit television
cfm	cubic feet per minute
CGA	Compressed Gas Association
CNG	compressed natural gas
dB	decibel
DBE	disadvantaged business enterprise
DC	direct current
DDU	operator display unit
DEF	diesel exhaust fluid
DOT	Department of Transportation
DPF	diesel particulate filter
ECM	Engine Control and Monitoring
ECS	emission control system
ELR	emergency locking retractor
EMI	electromagnetic interference
EPA	Environmental Protection Agency
ESS	energy storage system
FEA	Finite Element Analysis
FEMA	failure mode effects analysis
FMCSA	Federal Motor Carrier Safety Administration
FMCSR	Federal Motor Carrier Safety Regulations
FMVSS	Federal Motor Vehicle Safety Standards
FTA	Federal Transit Administration
GAWR	gross axle weight rated
GPS	global positioning system
GVW	gross vehicle weight
GVWR	gross vehicle weight rated
H-point	hip-point
HDS	hybrid drive system
HMI	human-machine interface
HSC	hybrid system controller
HV	high voltage

HVAC	heating, ventilation and air conditioning
I/O	input/output
IEEE	Institute of Electrical and Electronics Engineers
ISO	International Standards Organization
kJ	kilojoule
LEL	LED emergency light
LV	low voltage
mA	milli-ampere
MDT	mobile data terminal
MPa	mega-Pascal
NC	normally closed
NFPA	National Fire Protection Association
NGV	natural gas vehicle
NO_x	nitrogen oxide
NO	normally open
NTP	notice to proceed
OEM	original equipment manufacturer
OSI	Open Systems Interconnect
PA	public address
PMO	project management oversight
PPV	price per vehicle
PRD	pressure relief device
psi	pounds per square inch
RF	radio frequency
RFI	radio frequency interference
RTC	real-time clock
SAE	SAE International, formerly the Society of Automotive Engineers
scf	standard cubic feet
SFGC	Solar Heat Gain Coefficient
SLW	seated load weight
SOC	state of charge
UL	Underwriters Laboratories
UNECE	United Nations Economic Commission for Europe
V DC	volts of direct current
Wh	watt-hours
VIN	vehicle information number