

Exhibit C-1 – Project Site Plan Rendering

Costco Commercial Center Project

Conditional Use Permit Application No. P21-01959

Plan Amendment and Rezone Application No. P21-01960

Conditional Use Permit Application No. P21-03251

Planned Development Permit Application No. P21-03252

7120 North Riverside Drive Fresno, CA 93722

APN: 503-020-12

PROJECT DATA

CLIENT: COSTCO WHOLESALE
 999 LAKE DRIVE
 ISSAQUAH, WA 98027

PROJECT ADDRESS: NEC OF I-35 & NE 36TH ST
 FRESNO, CA

ACCESSOR'S PARCEL NUMBER: 503-020-12

SITE DATA:

COSTCO SITE AREA: 21.20 ACRES (923,869 SF)
 FUEL PARCEL AREA: 1.33 ACRES (57,753 SF)
TOTAL SITE AREA 22.53 ACRES (981,622 SF)

JURISDICTION: CITY OF FRESNO

EXISTING ZONING: CC/EA/cz
 PROPOSED ZONING: CG/cz

SETBACKS:	REQUIRED	ACTUAL
FRONT:	TBD	TBD
SIDE:	TBD	TBD
REAR:	TBD	TBD

BUILDING DATA:

TOTAL BUILDING FOOTPRINT AREA:	219,216 SF
INCLUDES:	
GROSS WAREHOUSE	167,960 SF
INCLUDES NET MECHANICAL / FIRE	1,188 SF
INCLUDES OPEN CANOPY	3,233 SF
GROSS MDO	46,834 SF

PARKING DATA:

TOTAL SITE PARKING:	873 STALLS
INCLUDES:	
10' WIDE STALLS	808 STALLS
ACCESSIBLE STALLS	25 STALLS
TOTAL RECEIVING PARKING:	40 STALLS
INCLUDES:	
10' WIDE STALLS	40 STALLS
EV STALL PARKING	92 STALLS

NUMBER OF STALLS PER 1000 SF OF BUILDING AREA: 3.98 STALLS

12' WIDE TRAILER PARKING 33 STALLS

NOTES:
 EXISTING CONDITIONS TO BE FIELD VERIFIED.

ANY SURVEY MONUMENTS WITHIN THE AREA OF CONSTRUCTION SHALL BE PRESERVED OR RESET BY A PERSON LICENSED TO PRACTICE LAND SURVEYING IN THE STATE OF CALIFORNIA

REPAIR ALL DAMAGED AND/OR OFF-GRADE CONCRETE STREET IMPROVEMENTS, AS DETERMINED BY THE CONSTRUCTION MANAGEMENT ENGINEER, PRIOR TO OCCUPANCY

2 WORKING DAYS BEFORE COMMENCING EXCAVATION OPERATIONS WITHIN THE STREET RIGHT-OF WAY AND/OR UTILITY EASEMENTS, ALL EXISTING UNDERGROUND FACILITIES SHALL HAVE BEEN LOCATED BY UNDERGROUND SERVICES ALERT (USA). CALL 1-800-642-2444

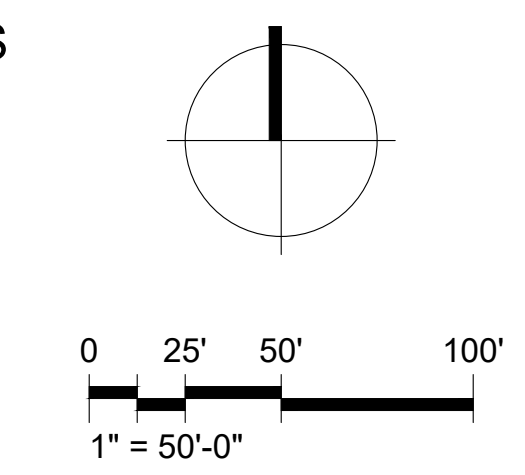

1101 Second Ave, Ste 100
 Seattle, WA 98101
 206 962 6500
 MG2.com



NOVEMBER 14, 2023

CONCEPT SITE PLAN

D11-34

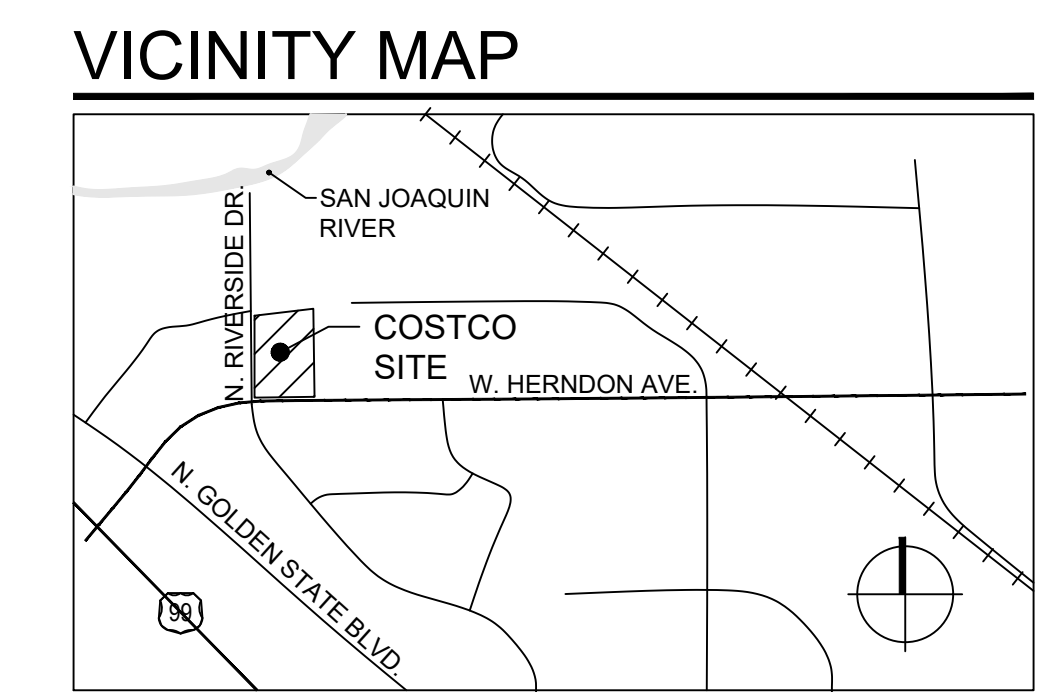
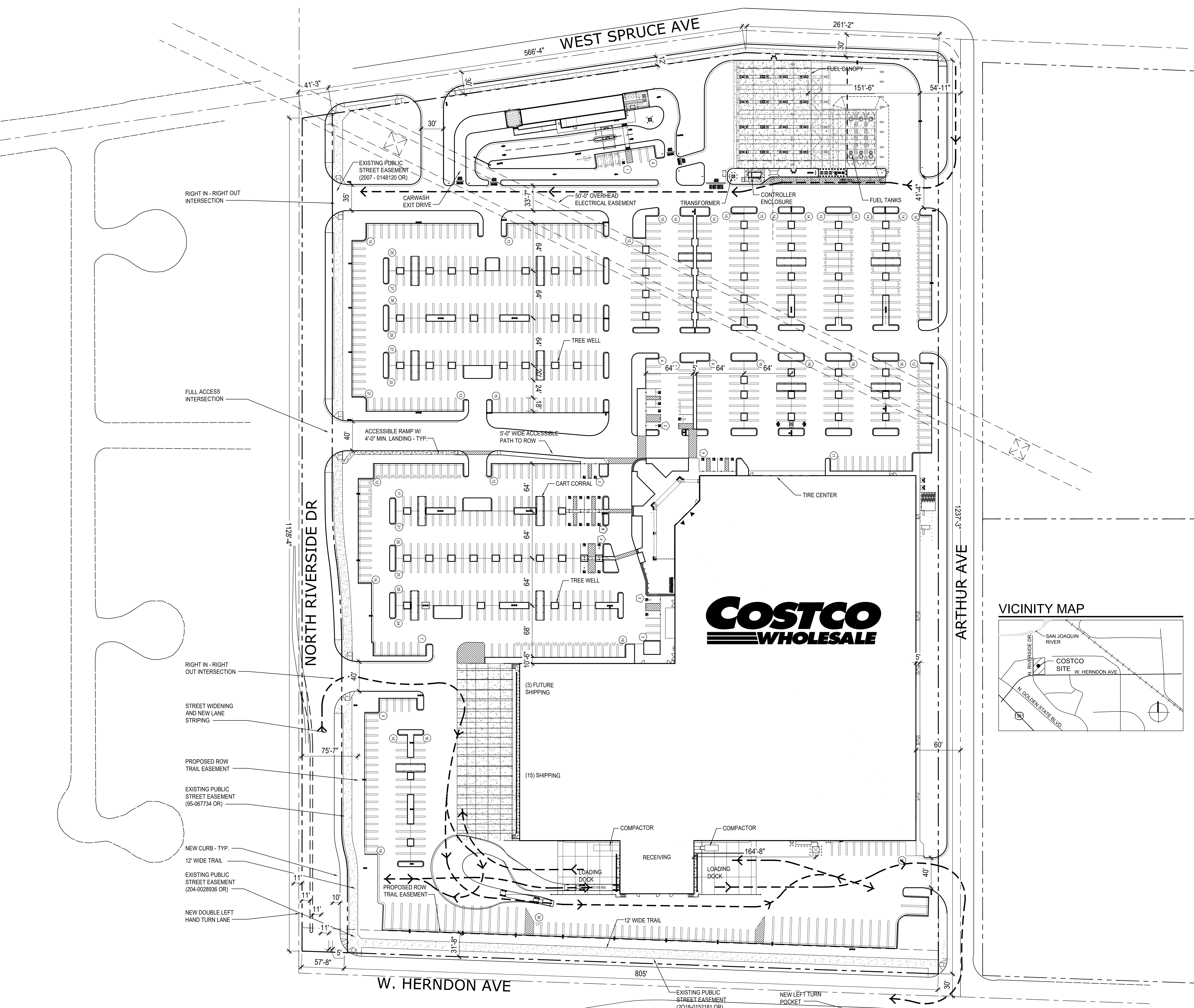

CONCEPT SITE PLAN