

Exhibit I



DATE: January 29, 2025

TO: Saul Perez, Planner II
Planning and Development Department

THROUGH: Jairo Mata, Public Works Traffic and Land Planning Manager
Public Works Department

FROM: Angela Reis, Chief Engineering Technician
Public Works Department, Traffic Planning Section

SUBJECT: Public Works Conditions of Approval
T-6397 / P23-01677 a 26-lot single family subdivision
1732 N Cornelia
SMS Construction / Dale G. Male

The Public Works Department, Traffic Operations and Planning Division, has completed its review and the following requirements are to be placed on this tentative map as a condition of approval by the Public Works Department.

General Conditions:

1. **Street Dedications:** Provide corner cut dedications at all intersections for accessibility ramps.
2. **Right of way:** All right-of-way “outside” of the subdivision border shall either be acquired **prior** to recordation of Final Map, or a deposit equal to the value of the right-of-way and an estimate of the City staff time necessary to acquire the right-of-way shall be submitted **prior** to recordation of the Final Map.
3. **Plan Submittal:** Submit the following plans, as applicable, in a single package, to the Public Works Department for review and approval **prior** to recordation of the Final Map. Street: construction, signing, striping, traffic signal and streetlight and Trail: construction, grading, lighting, striping, signing, landscape and irrigation.
4. **Local to Collector Street Intersections:** The intersection of two local continuous streets shall have a minimum of **160'** offset measured from centerline to centerline.
5. **Traffic Calming:** Traffic calming shall be provided for local street lengths exceeding **800'** and four-way intersections. Design to be approved on the street plans.
6. **Outlots:** If the subdivider seeks to dedicate to the City, in fee, an outlot for open space purposes, subdivider shall prove to the City that the outlot is free of toxic or hazardous materials pursuant to the requirements of *City Administrative Order 8-1*, including, but not limited to, performing a Phase I Soils Investigation. The soils Investigation report shall be submitted to the Public Works Department for review and approval. The

subdivider must obtain Public Works approval of the soils investigation report and complete any mitigation work identified by the soils investigation prior to subdivider's submittal of the Final Map to the Public Works Department. Any and all costs associated of the soils investigation and any required mitigation work shall be performed at the sole expense of the subdivider.

7. Encroachment Covenants: The construction of any private overhead, surface or sub-surface structures and appurtenances in the public right of way is prohibited unless an encroachment covenant is approved by the City of Fresno Public Works Department, Engineering Services Division, **(559) 621-8681**. Encroachment covenants must be approved prior to issuance of building permits.
8. Street widening and transitions shall also include utility relocations and necessary dedications.
9. Overhead Utilities: Underground all existing overhead utilities with the limits of this map in accordance with *Fresno Municipal Code Section 15-4114*.
10. Intelligent Transportation Systems (ITS): Street work on major streets shall be designed to include ITS in accordance with the *Public Works ITS Specifications*, where not existing.
11. Irrigation /Canal Requirements: The developer shall enter into an agreement with the Fresno Irrigation District (FID) providing for piping the canal(s) and submit an executed copy of the agreement or commitment letter from FID to the Public Works Department. All piping shall be located outside of the proposed street right of way. Any piping across city streets shall be rubber gasketed reinforced concrete pipe (RGRCP) constructed perpendicular to the street. Submit engineered plans to Public Works Department, Engineering Services Division for review and approval. Identify the proposed easement and provide a final cross-sectional detail on the map, **if applicable**.
12. Private Irrigation Pipe: If not abandoned, all piping shall be located outside of the proposed street right of way. Any piping across city streets shall be rubber gasketed reinforced concrete pipe (RGRCP) constructed perpendicular to the street. Submit engineered plans to the Public Works Department, Engineering Services Division for review and approval and provide an encroachment covenant for all crossings, **if applicable**.
13. Backing onto a major street: Backing onto a major street is prohibited.
14. The first order of work shall include a minimum of two points of vehicular access to the major streets for **any** phase of this development.
15. Intersection Visibility: Maintain visibility at all intersections as described in the *Fresno Municipal Code Section 15-2018*.
16. Driveway Approaches: The throat of the driveway approaches shall be the same width as the driveway. Approach widths shall be built to *Public Works Standard P-6*, **if applicable**.
17. FAX: When a bus shelter is required by the Transportation Department, FAX Division, a thicker sidewalk will be required. Contact Jeff Long at 559 621-1436. Coordinate all conditions of approval between Public Works and FAX.
18. Verify that the border is correct. Incorrect boundaries could result in extending timelines due to the need for separate processes, timelines and fees.
19. Revise local street cross sections to *Public Works Standard*.

20. When permanent facilities are not available from the Fresno Metropolitan Flood Control District, the applicant shall identify a temporary onsite storm water basin per *Public Works Standard P-97* for review and approval from Public Works.
21. Identify all easements on the map.
 - Local Streets: Local Streets: If constructed **42'** or **50'**, a **1'** pedestrian easement is required on streets with driveway approaches.

Frontage Improvement Requirements:

Public Streets:

Cornelia Avenue: 2-Lane Collector

1. Dedication and Vacation Requirements:
 - a. Dedicate **36'** of property, from section, for public street purposes, within the limits of this application, per *Public Works Standard P-54*.
 - b. Dedicate a corner cut for public street purposes at the intersection of Cornelia and Pine.
 - c. Relinquish direct access rights to Avenue from all lots within this subdivision.
2. Construction Requirements:
 - a. Construct concrete curb, gutter and a **6'** sidewalk to *Public Works Standard P-5*. The curb shall be constructed to a **12'** residential pattern (**5.5'– 6' - .5'**).
 - b. Planting and Irrigation of street trees shall conform to the minimum spacing, guidelines, and requirements as stated in the *Model Water Efficiency Landscape Ordinance, Public Works Standards and Specifications, Section 25 and 26*.
 - c. Construct standard curb ramps per *Public Works Standards P-28 and P-32, with R=20'* at all intersections.
 - d. Construct **20'** of permanent paving per *Public Works Standard P-50* (measured from face of curb) within the limits of this subdivision and transition paving, as necessary.
 - e. Construct an underground street lighting system to *Public Works Standard E-1 and E-7A, E-7B*, within the limits of this subdivision. Streetlights installed on major streets shall be fed from a service pedestal with a master photo control as detailed in *Section 3-3.17* of the *City Specifications and Standard Drawings E-15, E-17 and/or E-18* or as approved by the City Engineer.

Interior Streets: Not to PW Standards not approved as shown.

1. Dedicate, design and construct all driveways, ramps, curb, gutter, sidewalk, permanent paving, cul-de-sacs, easements and underground street lighting systems on all interior local streets to *Public Works Standards P-4, P-5, P-6, P-9 P-18, P-28, P-50, P-56A, P-56B, E-1 and E-9A, E-9B and E-11. 1'*
2. At entrance, provide transition as necessary from proposed 54' wide standard curb to 49' wide wedge curb.

3. All streets and pedestrian ways shall connect to other streets and pedestrian ways to form a continuous vehicular and pedestrian network with connections within the subdivision and to adjacent development. Pedestrian paths of travel must meet current accessibility regulations. Sidewalks are recommended on both sides of the street. Identify ramps within the proposed subdivision wherever sidewalks are provided.
4. Garages: Garage or carport setbacks are recommended to be a minimum of **18'** from the back of walk or curb, whichever is greater.
5. Provide a **12'** visibility triangle at all driveways.
6. Design local streets with a minimum of **250'** radius.
7. Turnaround:
Option 1. Redesign the dead-end street to allow for a cul-de-sac per Public Works Standard P18. The cul-de-sac will be built in a way that will allow for future access to the abutting property to the north. When the property to the north is developed, the cul-de-sac will go away and a traffic calming island will be constructed in its place.
Option 2. Construct a temporary turn-around on the abutting parcel to the north.

Within the subdivision border

1. Relinquish direct vehicular access rights to:
 - a. the west property line of lots 1 and 26.

Traffic Signal Mitigation Impact (TSMI) Fee: This project shall pay all applicable TSMI Fees **at the time of building permit**. Contact the Public Works Department, Frank Saburit at (559)621-8797. The fees are based on the Master Fee schedule. In some cases, traffic signals may be conditioned on multiple maps. If the signal is existing at the time of the final map, the applicant would not be required to construct the signal but would be required to pay the applicable fee.

Fresno Major Street Impact (FMSI) Fee: This Map is in the **New Growth Area**; therefore, pay all applicable growth area fees and City-wide regional street impact fees. In some cases, center section improvements or bridges may be conditioned on multiple maps. If the improvements are existing at the time of the final map, the applicant would not be required to construct them but would be required to pay the applicable fee.

Fresno Major Street Impact (FMSI) Requirements:

Cornelia Avenue: 2-Lane Collector (New Growth Area)

1. Dedicate and construct the following **within the limits of this subdivision**. Details of said street shall be depicted on the approved tentative tract map. Dedication shall be sufficient to accommodate arterial standard and any other grading or transitions as necessary based on a **45** MPH design speed.
 - a. Northbound: (1) **11'** center section travel lane.
 - b. Northbound: 7' Bike Lane.
 - c. Southbound: (1) **11'** center section travel lane and a **5'** shoulder.
 - d. Center section: a 12' center two-way left turn lane.
 - e. If not existing, an additional **8'** dedication is required beyond the edge of pavement.

Regional Transportation Mitigation Fee (RTMF): Pay all applicable **RTMF** fees to the Joint Powers Agency located at 2035 Tulare Street, Suite 201, Fresno, CA 93721; (559) 233-4148 ext. 200; www.fresnocog.org. Provide proof of payment or exemption **prior** to certificate of occupancy.



DATE: January 29, 2025

TO: Saul Perez, Planner II
Planning and Development Department

FROM: Adrian Gonzalez, Supervising Engineering Technician
Public Works Department, Land Planning & Subdivision Inspection Section

SUBJECT: PUBLIC WORKS CONDITIONS OF APPROVAL FOR VESTING TENTATIVE TRACT
MAP NO. 6397 REGARDING MAINTENANCE REQUIREMENTS (P23-01677)

LOCATION: 1732 North Cornelia Avenue

APN: 312-763-10

The Public Works Department, Land Planning & Subdivision Inspection Section, has completed its review and the following requirements are to be placed on this tentative map as a condition of approval. These requirements are based on City of Fresno code, policy, standards and the public improvements depicted on the exhibits submitted for this development.

ATTENTION:			
The item below requires a separate process with additional costs and timelines. In order to avoid delays with the final map approval, the following item shall be submitted for separate processing to the Public Works Department, Land Planning Section prior to final map approval.			
X	CFD Annexation Request Package	Adrian Gonzalez	(559) 621-8693 Luis.Gonzalez@fresno.gov

The Community Facilities District annexation process takes from three to four months and SHALL be completed prior to final map approval. INCOMPLETE Community Facilities District (“CFD”) Annexation Request submittals may cause delays to the annexation process and final map approval.

All applicable construction plans for this development shall be submitted to the appropriate City Department for review and approval **prior** to the CFD process.

- a. Landscape and Irrigation Plans are required to be approved prior to the finalization of the CFD process and the approval of the final map.
- b. Proposed park amenities shall be reviewed and approved by the Building & Safety Services Division or as approved in writing by the City Engineer at time of submittal for the CFD process and prior to final map approval.**

Requirements not addressed due to omission or misrepresentation of information, on which this review process is dependent, will be imposed whenever such conditions are disclosed and shall require a revision of this letter.

Any change affecting the items in these conditions shall require a revision of this letter.

The Property Owner's Maintenance Requirements

The long term maintenance and operating costs, including repair and replacement, of certain required public improvements ("Services") associated with all new Single-Family developments are the ultimate responsibility of the Developer. The Developer shall provide these Services either by a mechanism approved by the Public Works Department or by annexing to the City of Fresno's Community Facilities District No. 11 ("CFD No. 11").

The following public improvements (Existing and Proposed) are eligible for Services by CFD No. 11 as associated with this development:

- All landscaped areas, trees and irrigation systems, as approved by the Public Works Department, within the street rights-of-way and landscape easements; including without limitation, the median island (1/2, if fronting only one side of median), parkways, buffers, street entry medians and sides **(10' wide minimum landscaped areas allowed)** in **all Local and Major Streets**.
- All landscaping, trees, irrigation systems, hardscaping and amenities within Outlots having the purpose for open spaces and trails.
- Concrete curb and gutters, valley gutters, sidewalks, curb ramps, traffic calming structures, median island concrete maintenance band and cap (1/2, if fronting only one side of median), and street lights in **all Major Streets**.
- Concrete curb and gutters, valley gutters, sidewalks, curb ramps, traffic calming structures, and street entry and interior median island curbing and hardscape, street paving, street name signage and street lights in **all Local Streets**.

***All end lots, side yards, and front yards are the responsibility of the property owner and are not eligible for Services for maintenance by the CFD.**

The Property Owner may choose to do one or both of the following:

- a. The Property Owner may petition the City of Fresno to request annexation to CFD No. 11 by completing and submitting an Annexation Request Package to the Public Works Department, Land Planning Section for review and approval. The Annexation Request Form is available, along with current costs, on-line at the City's website at <http://www.fresno.gov>, under the Public Works Department, Land Development.
 - **Proceedings to annex the final map to CFD No. 11 SHALL NOT commence unless the final map is within the City limits and all construction plans** (this includes Street, Street Light, Signal, Landscape and Irrigation plans, and any other plans needed to complete the process) **and the final map are considered technically correct.**
 - The annexation process will be put on **HOLD** and the developer notified if all of the requirements for processing are not in compliance. **Technically Correct shall mean that**

the facilities and quantities to be maintained by CFD No. 11 are not subject to change and after acceptance for processing.

- Public improvements not listed above will require written approval by the Public Works Department Director or his designee.
 - All areas not within the dedicated street rights-of-way and approved for Services by CFD No. 11 shall be dedicated as a public easement for maintenance purposes. Outlots purposed for required public open space or City trails shall be dedicated in fee to the City of Fresno or as approved by the Public Works Department City Engineer.
- b. The Property Owner may provide for Services privately for the above maintenance requirements. All City maintenance requirements not included for annexation to CFD No. 11 for Services **SHALL** be included in the DCC&Rs or some other City approved mechanism for the required Services associated with this development. Contact the Planner in the Planning and Development Department for more details.

For questions regarding these conditions please contact Adrian Gonzalez at (559) 621-8693 or Luis.Gonzalez@fresno.gov

DEPARTMENT OF PUBLIC WORKS

TO: Saul Perez, Planner II
Planning & Development Department

FROM: Adrian Gonzalez, Supervising Engineering Technician
Public Works, Land Planning & Subdivision Inspection Section

DATE: January 29, 2025

SUBJECT: P23-01677; Tract 6397 (APN: 312-763-10) located on the east side of North Cornelia Avenue, south of West McKinley Avenue. The Department of Public Works offers the following comments regarding the requirements for landscaping and irrigation in the street rights-of-way, landscape easements, outlots and median islands:

GENERAL REQUIREMENTS

STREET TREE REQUIREMENTS

1. The subdivider is required to provide street trees on all public street frontages per Fresno Municipal Code and for the dedication of planting and buffer landscaping easements as determined by the Planning Department. Street trees shall be planted at the minimum rate of one tree for each 40' of street frontage or one tree per home (whichever is greater) by the Developer. The subdivider is required to provide irrigation for all street trees. The irrigation system shall comply with AB 1881.
2. Street Tree Planting by Developer: For those lots having internal street tree frontage available for street tree planting, the developer shall plant one tree for each 40' of street frontage, or one tree per lot having street frontage, whichever is greater. Tree planting shall be within a street or landscape easement.
 - a. Street tree inspection fees shall be collected for each 40' of public street frontage or one tree per lot whichever is greater.
 - b. Street trees shall be planted in accordance with the City of Fresno, Department of Public Works "Standard Specifications."
 - c. Landscape plans for all public use areas, such as parkways, buffers, medians and trails, shall be reviewed and approved by the Department of Public Works, Engineering Services. A street tree planting permit shall be required for all residential street tree planting.
 - d. Performance and payment securities, paid with final map, will be released when all landscaping installed on public and/or city-controlled property is in conformance with the Specifications of the City of Fresno.
 - e. Upon acceptance of the required work, warranty security shall be furnished to or retained by the city for guaranty and warranty of the work for a period of ninety days following acceptance.

- f. Choose appropriate trees from the list of Approved Street Trees. [Developer Doorway – City of Fresno](#)

BUFFER LANDSCAPING & MAINTENANCE REQUIREMENTS

1. The subdivider shall provide long term maintenance for all proposed landscaped areas by either petitioning for annexation in the Community Facilities District or by forming a Homeowner's Association.
2. Maintenance Service Through Annexation into the Community Facilities District. Landscape and Irrigation plans are required and shall be submitted to the Department of Public Works for review and approval prior to Council approval of the final map. Plans shall be numbered to conform to and be included in the Department of Public Works Street construction plan set for the final map. Fees are applicable when the subdivider elects to have landscaping maintained by annexing into the City's Community Facilities District.
 - a. Landscaping shall comply with Landscape Buffer Development Standards approved by the City Council on October 2, 1990. Landscape and irrigation plans shall comply with AB1881, water efficient landscaping.
 - b. Should the proposed landscape buffers and/or parkway strips be located next to an existing buffer and/or parkway strip, the planting concept shall simulate the adjacent landscape design to present a more uniform appearance on the street. Variances in the landscape concept will be acceptable, but the design of the new landscape buffer and/or parkway strip shall strive to mimic the existing as much as possible.
 - c. Landscape plans shall indicate grades on a cross-section detail to include fencing or wall details. All fencing shall be placed outside the landscape easement. Maximum slopes shall not exceed 4:1 with 1 foot of level ground between the slope and the back of the sidewalk and/or face of fence. Erosion control measures shall be implemented on all slopes of 4:1, including the use of synthetic erosion control netting in combination with ground cover species approved by the Department of Public Works/Engineering Services Division.
 - d. The water meter(s) serving the buffer landscaping shall be sized for the anticipated service flows.
 - e. No private flags, signs or identification of any kind shall be permitted in the right-of-way, within the City - controlled easement or on the fence or wall facing the street.
 - f. Landscaping in the right-of-way and landscape setback adjacent to water well sites shall be the responsibility of the City of Fresno Water Division and may not be included in the CFD.

OUTLOTS

1. Outlots which are utilized for water well purposes **will not** be included in the CFD. The Water Division Department in Public Utilities will provide the maintenance of all plant material on the well site.

Submit all landscape and irrigation plans, to the scale of 1" = 20', to dpwplansubmittal@fresno.gov for plan review, prior to the installation of any landscaping within the right-of-way.

NOTES

1. SITE ADDRESS: 1732 N. CORNELIA AVE
2. ASSessor's PARCEL NO.: 312-763-10
3. EXISTING ZONING: RS-4
4. EXISTING GENERAL PLAN LAND USE: MEDIUM LOW DENSITY
5. PROPOSED ZONING: RS-4
6. PROPOSED LAND USE: RESIDENTIAL, SINGLE FAMILY
7. PREPARED FROM RECORD DATA & FIELD SURVEYS
8. EXISTING STRUCTURES ON SITE TO BE DEMOLISHED
9. EXISTING STREET IMPROVEMENTS AS SHOWN
10. ALL EXISTING WELLS, SEPTIC TANKS, OR LEACHING FIELDS TO BE DEMOLISHED PER STATE AND CITY STANDARDS
11. PARCEL DESIGN PROVIDES FOR OPTIMUM SOLAR OPPORTUNITIES WITH NORTH-SOUTH ORIENTATION, ENABLING ARCHITECTURAL DESIGN TO INCORPORATE PASSIVE HEATING & COOLING CONCEPTS.
12. EXISTING SITE LAND USE: SINGLE FAM. RESIDENTIAL SURROUNDING LAND USE: SINGLE FAM. RESIDENTIAL
13. THE EXISTING & PROPOSED SOURCE OF WATER SUPPLY: CITY OF FRESNO COMMUNITY SYSTEM
14. THE EXISTING & PROPOSED METHOD OF SEWAGE DISPOSAL: CITY OF FRESNO COMMUNITY SYSTEM
15. THE FOLLOWING UTILITIES ARE TO BE PROVIDED: (GAS, ELECTRIC, TELEPHONE & CABLE T.V.) COMPANIES SERVING THIS AREA
16. THE SITE ADREAGE IS 4.94 GROSS ACRES, 4.72 NET ACRES, THERE WILL BE 26 LOTS IN THIS MAP WITH A MINIMUM SIZE OF 4,630 SQ FT
17. ALL IMPROVEMENTS SHALL CONFORM WITH THE DESIGN STANDARDS IN ACCORDANCE WITH THE CITY OF FRESNO STANDARDS AND SPECIFICATIONS
18. PROPOSED SITE IMPROVEMENTS SHALL INCLUDE: SITE GRADING AND DRAINAGE, UTILITY SERVICE AS DIRECTED BY ALL UTILITY AGENCIES, DRAINAGE FACILITIES AS REQUIRED
19. THE APPROXIMATE TOTAL AMOUNT OF EXISTING ON-SITE TREES TO BE REMOVED IS 23.
20. OUTLOT 'A' WILL BE USED AS A COMMON AREA FOR LANDSCAPE PURPOSES.
21. OUTLOT 'B' WILL BE USED AS A COMMON AREA FOR LANDSCAPE PURPOSES.
22. NO PERMETER DESIGN GRADES ARE ANTICIPATED TO EXCEED 6" OF DIFFERENTIAL FROM EXISTING GRADE
23. PREPARED FROM FIELD SURVEYS AND RECORD DATA TRACT 5321, PLATS VOL 72, PAGE 75, FOR

LEGEND:

- (E) SINGLE POST SIGN
 - (E) POWER POLE
 - (E) POWER POLE W/ TRANSFORMER
 - (E) SERVICE POLE
 - (E) ELECTRICAL PULL BOX
 - (E) TELEPHONE RISER
 - (E) CABLE TV BOX
 - (E) SEWER MANHOLE
 - (E) WATER VALVE
 - (E) WATER WELL (TO BE ABANDONED) PER CITY STD W-45
 - (E) OVERHEAD ELECTRICAL LINE
 - (E) UNDERGROUND GAS LINE
 - (E) WATER MAIN/VALVE
 - (E) SEWER MAIN/VALVE
 - JR-1 RECORD DATA PER TRACT NO.5321 FILED IN VOLUME 72 AT PAGES 75-77 OF PLATS, FRESNO COUNTY RECORDS
 - (E) 30' STREET EASEMENT
- SECTION LINE
 - PROPOSED 1" WATER METER PER CITY STD W-2
 - PROPOSED WATER BLOW OFF PER CITY STD W-9
 - PROPOSED FIRE HYDRANT PER CITY STD W-3
 - PROPOSED SANITARY SEWER MANHOLE PER CITY STD S-3
 - PROPOSED DRAINAGE FLOW
 - PROPOSED 6" WOOD FENCE PER DETAIL SHT 2
 - PROPOSED WATER MAIN & SIZE
 - PROPOSED SEWER MAIN & SIZE
 - PROPOSED EASEMENT
 - PROPOSED FIRE LANE "NO PARKING"
 - PROPOSED PORTION OFFERED FOR DEDICATION FOR PUBLIC STREET
 - (E) CONTOUR LINES & ELEVATION
 - PROPOSED STREET LIGHT PER CITY STD. E94

REVISIONS/ LEGEND:

1. PROPOSED WEDGE CURB, GUTTER & SIDEWALK PER CITY STD P-9
 2. PROPOSED 10' PUBLIC UTILITY EASEMENT (P.U.E.)
 3. SLAB STREET FOR FUTURE EXTENSION INSTALL CITY STANDARD BARRICADE
 4. PROPOSED CONCRETE CURB, GUTTER & SIDE WALK PER CITY OF FRESNO PUBLIC WORKS STANDARD P-5 & P-9.
 5. PROPOSED CURB TRANSITION TO MEDGE CURB
 6. PROPOSED 40' RADIUS TEMPORARY TURNING EASEMENT SHOWN HATCHED. EXTEND 6" CONCRETE SIDEWALK TO LIMITS OF 40' RADIUS FOR TEMP SURFACE
 7. PROPOSED 6" WOOD FENCE PER DETAIL ON SHEET 2
 8. PROPOSED 6" CMU BLOCK FENCE PER CITY STD. P-94C
 9. INSTALL FH ASSEMBLY PER CITY STD W-3
- PROPOSED TEMPORARY TURNING EASEMENT TO BE ABANDONED WITH EXTENSION OF NORTH LODI STREET
- PROPOSED TEMPORARY ON-SITE STORM WATER BASIN.

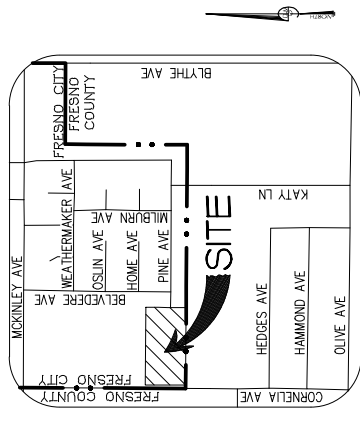

LEGAL DESCRIPTION:
THE LAND DESCRIBED HEREIN IS SITUATED IN THE STATE OF CALIFORNIA, COUNTY OF FRESNO, CITY OF FRESNO, DESCRIBED AS FOLLOWS:
THE SOUTH 326 FEET OF THE WEST ONE-HALF (W 1/2) OF THE NORTHWEST ONE-QUARTER (NW 1/4) OF THE NORTHWEST ONE-QUARTER (NW 1/4) OF SECTION 35, TOWNSHIP 13 SOUTH, RANGE 19 EAST, M.D.B. AND M., ACCORDING TO THE UNITED STATES GOVERNMENT TOWNSHIP PLATS.

VESTING TENTATIVE TRACT MAP NO. 6397
'PINE VILLAS'
BEING A PORTION OF SECTION 35, TOWNSHIP 13 SOUTH, RANGE 19 EAST, MOUNT DIABLO BASE & MERIDIAN

SITE LOCATION:
1732 N CORNELIA AVE, FRESNO, CALIFORNIA
ASSessor's PARCEL NO.S: 312-763-10

PREPARED FOR:
SMS CONSTRUCTION
280 SHAW AVE. SUITE B
CLOVIS, CALIFORNIA 93612
PHONE: 559-952-7617

PREPARED BY:
DALE G. MELL
& ASSOCIATES
ENGINEERING & SURVEYING SERVICES
559 952 4064 FAX 559 952 7803
2825 WINDYBUSH DRIVE, CLOVIS, CALIFORNIA 93612

JOB # 21-066
DRAWN BY: DGM/JM
CHECKED BY: DGM
SCALE: 1" = 40'
DATE: 08/29/21
PLAT # 6397
DATE OF SURVEY: 08/19/21
LAST REVISION: 10/05/21

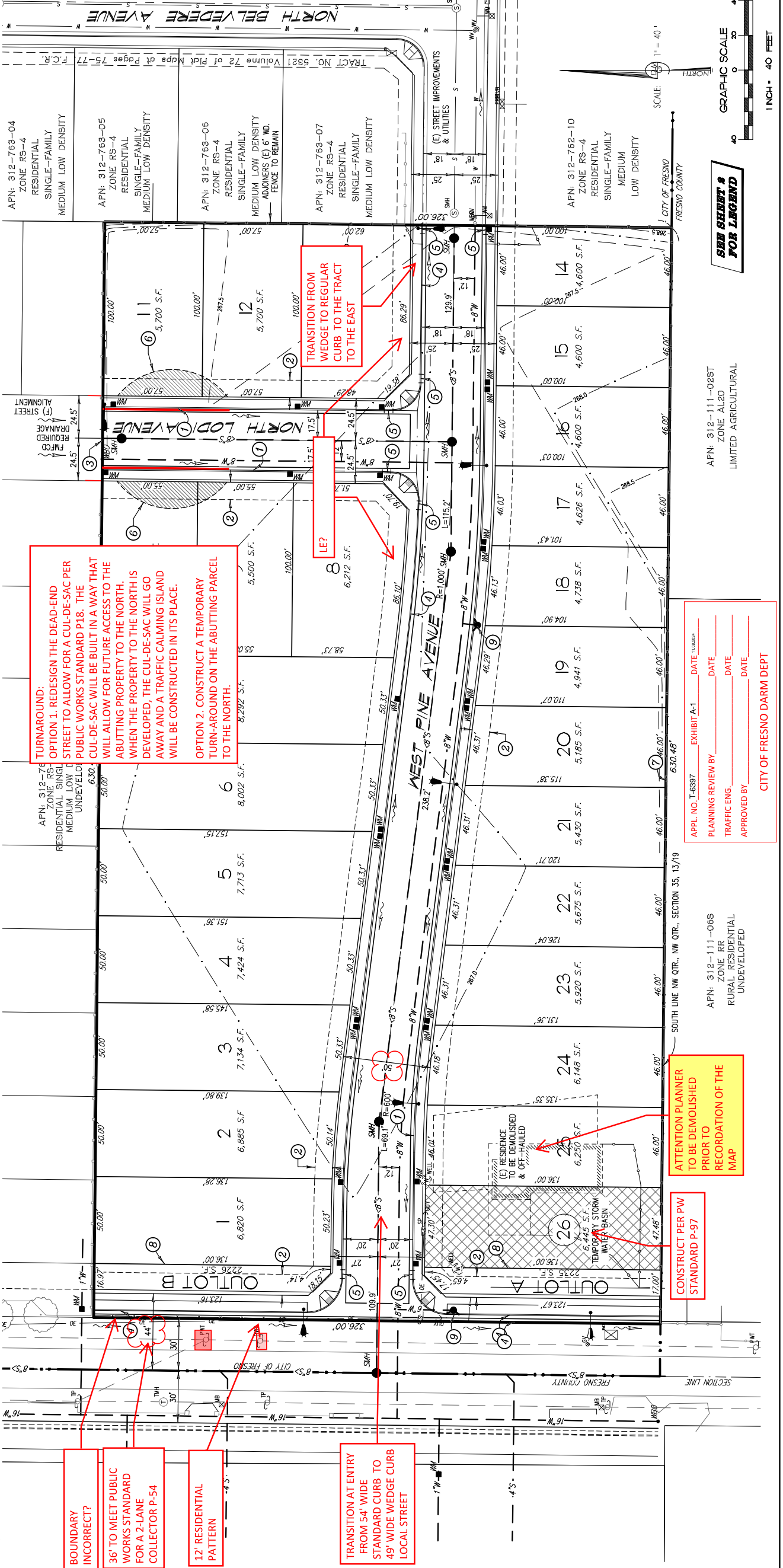

FIRE DEPARTMENT NOTE:
ALL RESIDENTIAL HOMES SHALL INSTALL FIRE SPRINKLER SYSTEMS PER NFPA 13D 2022 STANDARDS.

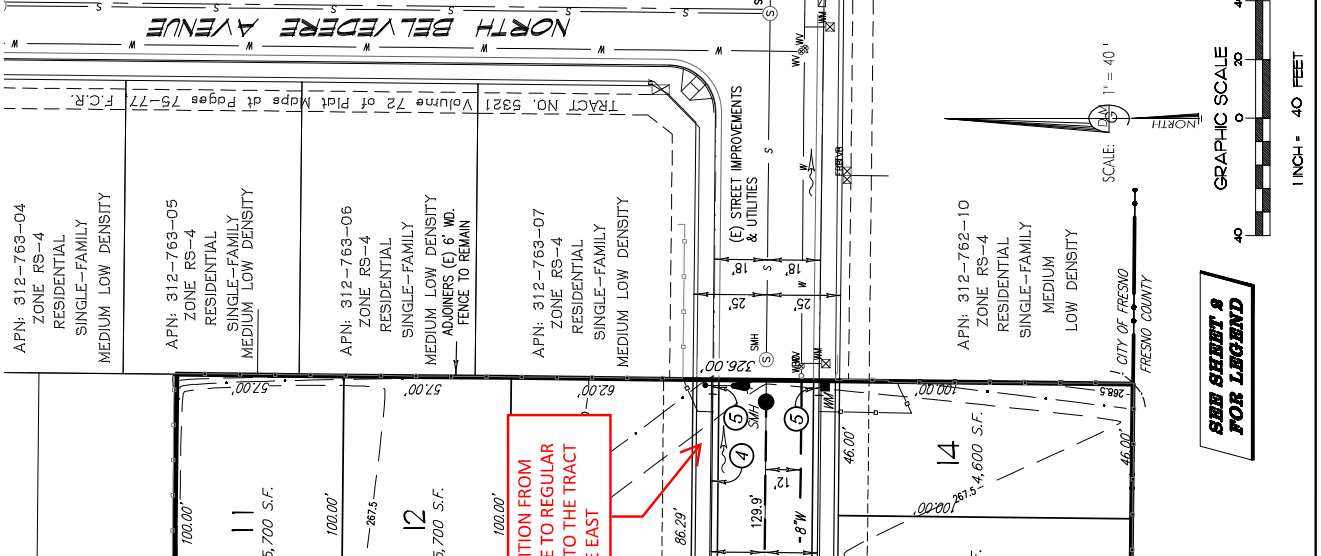

APPL. NO. T-6397 EXHIBIT A-1 DATE: 10/05/2024

PLANNING REVIEW BY: _____ DATE: _____

TRAFFIC ENG. _____ DATE: _____

APPROVED BY: _____ DATE: _____

CITY OF FRESNO DARM DEPT

APN: 312-111-065 ZONE RR RURAL RESIDENTIAL UNDEVELOPED

APN: 312-111-025T ZONE AL20 LIMITED AGRICULTURAL

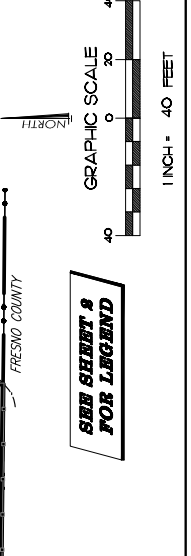



DALE G. MELL & ASSOCIATES
ENGINEERING & SURVEYING SERVICES
8595 POK - FLS - 154220 - 046116 - 0001 - 0001 - 0001
280 SHAW AVE. SUITE B
CLOVIS, CALIFORNIA 93618
PHONE: 559-952-7617

PREPARED FOR:
SMS CONSTRUCTION

SITE LOCATION:
1732 N. CORNELIA AVE. FRESNO, CALIFORNIA
ASSESSOR'S PARCEL NO(S):
312-763-10

BEING A PORTION OF SECTION 35,
TOWNSHIP 13 SOUTH, RANGE 19 EAST,
"PINE VILLAS"
VESTING TENTATIVE TRACT MAP NO. 6397

APPL. NO. T-6397 EXHIBIT A-2 DATE (1/1/2024)
PLANNING REVIEW BY: _____ DATE _____
TRAFFIC ENG. _____ DATE _____
APPROVED BY: _____ DATE _____
CITY OF FRESNO DARM DEPT

NOTES
1. 4" SEWER LATERALS & 1" WATER METERS TO BE INSTALLED ON EACH LOT FRONTING UTILITY IMPROVEMENTS

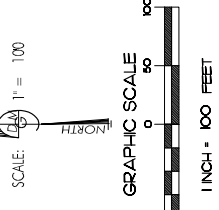

TYPICAL 49' R/W SECTION NORTH LODI AVENUE

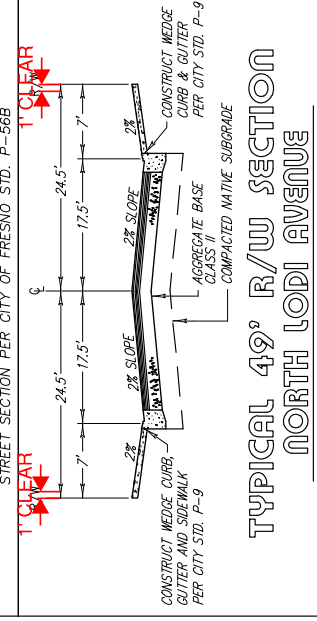

TYPICAL 54' R/W SECTION WEST PINE AVENUE

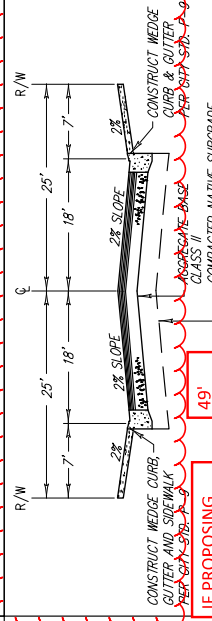

TYPICAL 54' R/W SECTION WEST PINE AVENUE

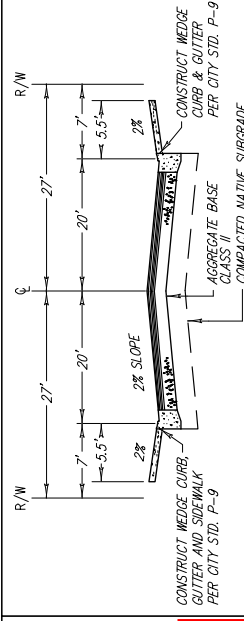

WOOD FENCE DETAIL
SECTION A1-A1

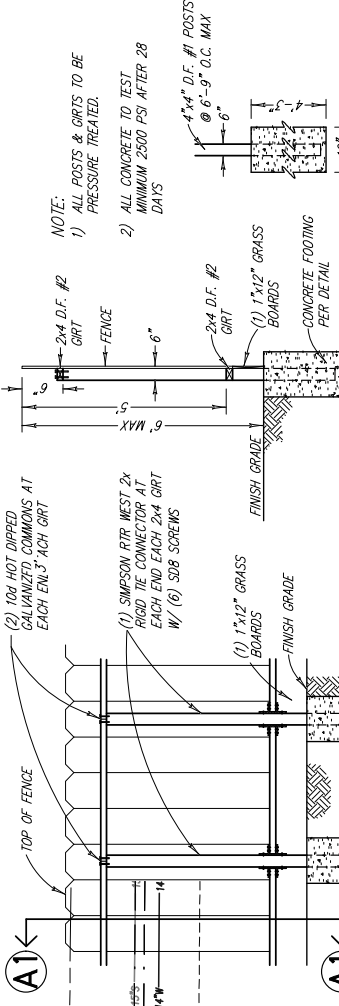

TYPICAL 88' R/W SECTION COLLECTOR STREET NORTH CORNELIA AVENUE

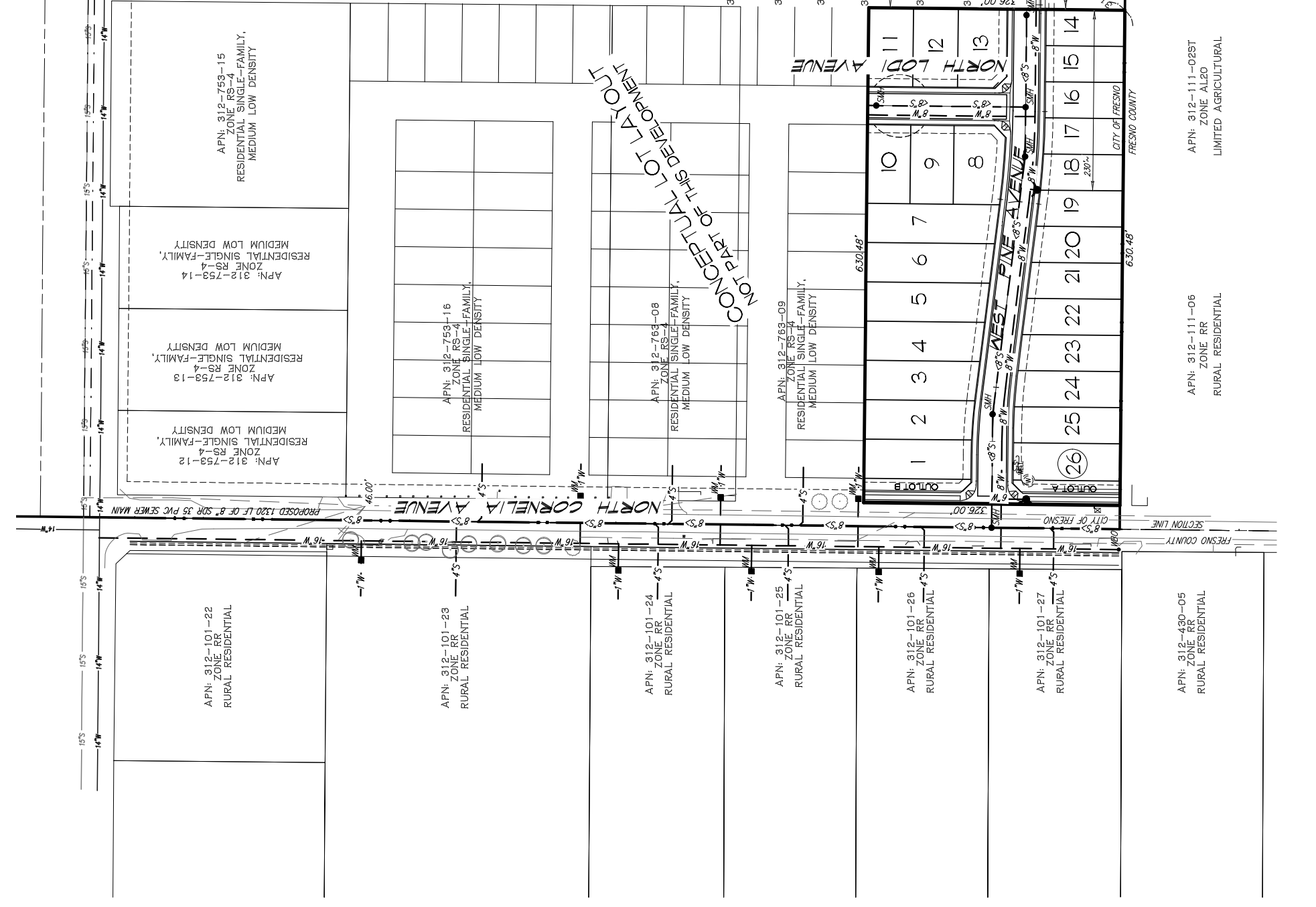
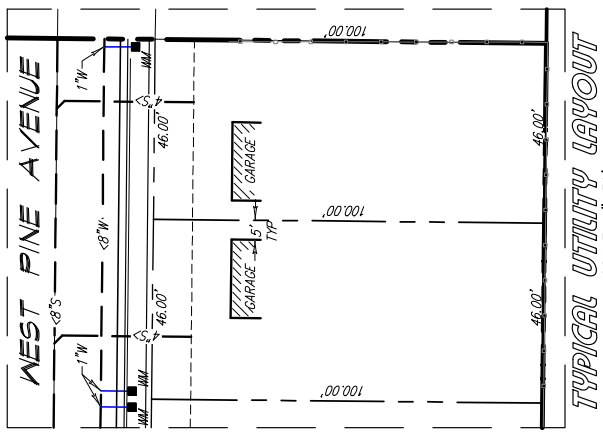
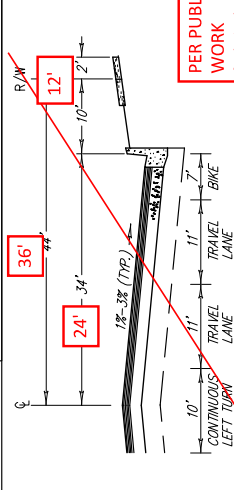

APN: 312-111-06
ZONE RR
RURAL RESIDENTIAL

APN: 312-111-02ST
ZONE AL20
LIMITED AGRICULTURAL

APN: 312-430-05
ZONE RR
RURAL RESIDENTIAL

CONCEPTUAL LOT LAYOUT
NOT PART OF THIS DEVELOPMENT



DEPARTMENT OF PUBLIC UTILITIES

MEMORANDUM

DATE: October 28, 2024

TO: SAUL PEREZ – PLANNER II
Planning & Development Department – Current Planning

FROM: DENISE SORIA, MSCE, PE, Licensed Professional Engineer
Department of Public Utilities – Utilities Planning & Engineering

DEJAN PAVIC, PE, Projects Administrator
Department of Public Utilities – Utilities Planning & Engineering

**SUBJECT: DPU CONDITIONS OF APPROVAL FOR P23-01677 TENTATIVE TRACT
MAP T-6397 – SEC OF MCKINLEY & CORNELIA (PINE VILLAS) – APN
312-763-10 (Cross-reference Pre-Application P21-05394)**

General Requirements

1. Engineered improvement plans, prepared by a Registered Civil Engineer, if necessary, shall be submitted for Department of Public Utilities review and approval.
2. All Department of Public Utilities facilities shall be constructed in accordance with the Department of Public Works standards, specifications, and policies.
3. Street easements and/or deeds shall be recorded prior to approval of improvement plans.
4. A street work permit is required for any work in the Right-of-Way.
5. All underground utilities shall be installed prior to permanent street paving.
6. **Attached to these DPU Conditions of Approval is a preliminary review of the Site Plan for the Project (as such Site Plan was available on Accela as of the date of these Conditions of Approval). Final Site Plan review will be conducted after an update based on these and other conditions for the Project.**

Water Service Requirements

The nearest water mains to serve the Project are a 14-inch water main located in West McKinley Avenue and an 8-inch water main located in West Pine Avenue. Water facilities are available to provide service to the Project subject to the following requirements:

1. Install a 14-inch water main (including installation of City fire hydrants, if applicable) in North Cornelia Avenue from the existing 14-inch water main located in West McKinley Avenue to the southwest corner of the Project.
2. Install 8-inch water mains (including installation of City fire hydrants, if applicable) in West Pine Avenue and North Lodi Avenue within the Project (as depicted on the

Vesting Tentative Tract Map uploaded to Accela on 10/07/2024) to provide service to each lot.

3. Installation of water service(s) and meter(s) to each lot shall be required.
4. The applicant shall be financially responsible for the abandonment of any unused water services previously installed at the property.
5. Destroy any existing on-site well(s) in compliance with the State of California Well Standards, Bulletins 74-81 and 74-90, or current revisions, issued by California Department of Water Resources, Fresno County standards, and City of Fresno standards. The applicant shall comply with Fresno Municipal Code (FMC) Chapter 6, Article 4, as may be amended from time to time.

Note: Based on the Tentative Tract Map (uploaded to Accela on October 7, 2024) there is an existing residence on the property and existing wells on-site. Based on the Tentative Tract Map, both the residence and on-site wells will be destroyed.

6. Two independent sources of water, meeting Federal and State Drinking Water Act Standards, are required to serve the tract including any subsequent phases thereof. The two-source requirement may be accomplished through any combination of water main extensions, construction of supply wells, or other acceptable sources of water supply approved by the Department of Public Utilities Director.

Water Supply Requirements

The existing property is currently not served by a City water service.

1. The applicant shall be required to pay water Capacity Fee charges for the installation of new water services and meters to serve the property.
 - a. The Water Capacity Fee charge assessed to the applicant shall be based on the number and size of service connections and water meters required to serve the property.
 - b. The Water Capacity Fee charges by meter size are defined in the City's Master Fee Schedule (MFS).
 - c. The City reserves the right to require the applicant to increase or decrease the size of a water meter for the Project to ensure that it is properly sized to accommodate fire protection requirements and to allow for accurate volumetric flow measurements at low- and high-flow conditions.
 - d. The Water Capacity Fee charge for any new or expanded service connection shall be payable prior to the issuance of a building permit at the fee level in effect on the date such permit is issued.
2. The applicant shall be required to pay all other water-related fees and charges in accordance with the City's MFS and the FMC.

Sewer Service Requirements

The nearest sanitary sewer mains to serve the Project are a 15-inch sewer main located in West McKinley Avenue and an 8-inch sewer main located in West Pine Avenue. Sanitary sewer facilities are available to provide service to the Project subject to the following requirements:

1. A preliminary sewer design layout shall be prepared by the applicant's engineer and submitted to the Department of Public Utilities for review and conceptual approval prior to submittal for City review or acceptance of the final map(s) and engineered plan and profile improvement drawing(s).
2. Install an 8-inch sanitary sewer main in North Cornelia Avenue from the existing 15-inch sanitary sewer main located in West McKinley Avenue to the southwest corner of the Project.
3. Install 8-inch sanitary sewer mains in West Pine Avenue and North Lodi Avenue within the Project (as depicted on the Vesting Tentative Tract Map uploaded to Accela on 10/07/2024) to provide service to each lot.
4. Installation of separate sewer service branch(es) to each lot shall be required.
5. The applicant shall be financially responsible for the abandonment of any unused sewer services previously installed at the property, if any.
6. All existing on-site private septic systems (including septic tanks) shall be destroyed and abandoned in compliance with the State of California standards, Fresno County standards, and City of Fresno standards, as may be amended from time to time. All sewer connections and sewer main extensions shall comply with FMC Section 6-303(a), as may be amended from time to time.

Note: Based on the Tentative Tract Map (uploaded to Accela on October 7, 2024) there is an existing residence on the property and existing wells on-site. According to the Tentative Tract Map, both the residence and on-site well will be destroyed.

Sanitary Sewer Fees

The following Sewer Connection Charges are due and shall be paid for the Project:

1. Lateral Sewer Charge.
2. Oversize Sewer Charge: Area #26.
3. Wastewater Facility Sewer Charge (Single-Family Residential).
4. Sewer Trunk Area: Cornelia.

Solid Waste Service Requirements

This Project will be serviced as a Single-Family Residential property with Basic Container Service. Each unit will receive 3 containers to be used as follows: 1 (one) Gray container for solid waste, 1 (one) Green container for green waste, and 1 (one) Blue container for recyclable material.

1. Provide a 44-foot (centerline) turning radius at all corners and a T-turnaround (or hammerhead) area where the solid waste vehicle is to turn around.
2. Ingress and egress of the location shall have an unobstructed overhead clearance of 16 feet and shall not be less than 18 feet wide.
3. The safe back up limit for a solid waste vehicle shall not exceed 45 feet.

DPU 1
10/16/2024
CCB

NOTES:

- 1 SITE ADDRESS: 1732 N. CORNELIA AVE
- 2 ASSESSOR'S PARCEL NO.: 312-763-10
- 3 EXISTING ZONING: RS-4 RESIDENTIAL SINGLE FAMILY, MEDIUM LOW DENSITY
- 4 EXISTING GENERAL PLAN LAND USE: MEDIUM LOW DENSITY
- 5 PROPOSED ZONING: RS-4 RESIDENTIAL SINGLE FAMILY, MEDIUM LOW DENSITY
- 6 PROPOSED LAND USE: RESIDENTIAL, SINGLE FAMILY
- 7 PREPARED FROM RECORD DATA & FIELD SURVEYS
- 8 EXISTING STRUCTURES ON SITE TO BE DEMOLISHED
- 9 EXISTING STREET IMPROVEMENTS AS SHOWN
- 10 ALL EXISTING WELLS, SEPTIC TANKS, OR LEACHING FIELDS TO BE DEMOLISHED PER STATE AND CITY STANDARDS
- 11 PARCEL DESIGN PROVIDES FOR OPTIMUM SOLAR OPPORTUNITIES WITH NORTH-SOUTH ORIENTATION, ENABLING ARCHITECTURAL DESIGN TO INCORPORATE PASSIVE HEATING & COOLING CONCEPTS.
- 12 EXISTING SITE LAND USE: SINGLE FAM. RESIDENTIAL SURROUNDING LAND USE: SINGLE FAM. RESIDENTIAL
- 13 THE EXISTING & PROPOSED SOURCE OF WATER SUPPLY: CITY OF FRESNO COMMUNITY SYSTEM
- 14 THE EXISTING & PROPOSED METHOD OF SEWAGE DISPOSAL: CITY OF FRESNO COMMUNITY SYSTEM
- 15 THE FOLLOWING UTILITIES ARE TO BE PROVIDED: (GAS, ELECTRIC, TELEPHONE & CABLE T.V.) ARRANGEMENTS HAVE (NOT) BEEN MADE WITH UTILITY COMPANIES SERVING THIS AREA
- 16 THE SITE ACREAGE IS 4.94 GROSS ACRES, 4.72 NET ACRES, THERE WILL BE 26 LOTS IN THIS MAP WITH A MINIMUM SIZE OF 4,690 SQ FT
- 17 ALL IMPROVEMENTS SHALL CONFORM WITH THE DESIGN STANDARDS IN ACCORDANCE WITH THE CITY OF FRESNO STANDARDS AND SPECIFICATIONS
- 18 PROPOSED SITE IMPROVEMENTS SHALL INCLUDE SITE GRADING AND DRAINAGE, UTILITY SERVICE AS DIRECTED BY THE UTILITY AGENCIES, DRAINAGE FACILITIES AS REQUIRED
- 19 THE APPROXIMATE TOTAL AMOUNT OF EXISTING ON-SITE TREES TO BE REMOVED IS 23.
- 20 OUTLOT 'A' WILL BE USED AS A COMMON AREA FOR LANDSCAPE PURPOSES.
- 21 OUTLOT 'B' WILL BE USED AS A COMMON AREA FOR LANDSCAPE PURPOSES.
- 22 NO PERIMETER DESIGN GRADES ARE ANTICIPATED TO EXCEED 6" OF DIFFERENTIAL FROM EXISTING GRADE
- 23 PREPARED FROM FIELD SURVEYS AND RECORD DATA TRACT 5321, PLATS VOL 72, PAGE 75, FOR

LEGEND:

- | | |
|--|---|
| (E) SINGLE POST SIGN | SECTION LINE |
| (E) POWER POLE | PROPOSED 1" WATER METER PER CITY STD. W-2 |
| (E) POWER POLE W/ TRANSFORMER | PROPOSED WATER BLOW OFF PER CITY STD W-9 |
| (E) SERVICE POLE | PROPOSED FIRE HYDRANT PER CITY STD W-3 |
| (E) ELECTRICAL PULL BOX | PROPOSED SANITARY SEWER MANHOLE PER CITY STD S-3 |
| (E) TELEPHONE RISER | PROPOSED DRAINAGE FLOW |
| (E) CABLE TV BOX | PROPOSED 6" WOOD FENCE PER DETAIL SHT 2 |
| (E) SEWER MANHOLE | PROPOSED WATER MAIN & SIZE |
| (E) WATER VALVE | PROPOSED SEWER MAIN & SIZE |
| (E) WATER WELL (TO BE ABANDONED) PER CITY STD W-45 | PROPOSED EASEMENT |
| (E) OVERHEAD ELECTRICAL LINE | PROPOSED FIRE LANE "NO PARKING" |
| (E) UNDERGROUND GAS LINE | PROPOSED PORTION OFFERED FOR DEDICATION FOR PUBLIC STREET |
| (E) WATER MAIN/LINE | (E) CONTOUR LINES & ELEVATION |
| (E) SEWER MAIN/LINE | PROPOSED STREET LIGHT PER CITY STD. E9A |
| RECORD DATA PER TRACT NO. 5321 FILED IN VOLUME 72 AT PAGES 75-77 OF PLATS, FRESNO COUNTY RECORDS | |
| (E) 30' STREET EASEMENT | |

Please add symbol and definition for existing wells.

KEYNOTES/ LEGEND:

- 1 PROPOSED WEDGE CURB, GUTTER & SIDEWALK PER CITY STD P-9
- 2 PROPOSED 10' PUBLIC UTILITY EASEMENT (P.U.E.)
- 3 PROPOSED TRAFFIC CALMING, CONSTRUCT 3" RAISED PAVEMENT SECTION UTILIZING DURATHERM INSTALLATION AND THERMOPLASTIC MATERIALS
- 4 PROPOSED CONCRETE CURB, GUTTER & SIDE WALK PER CITY OF FRESNO PUBLIC WORKS STANDARD P-5 & P-9.
- 5 PROPOSED CURB TRANSITION TO WEDGE CURB
- 6 PROPOSED 40' RADIUS TEMPORARY TURNING EASEMENT SHOWN HATCHED.
- 7 PROPOSED 6' WOOD FENCE PER DETAIL ON SHEET 2
- 8 PROPOSED 6' CMU BLOCK FENCE PER CITY STD. P-94C
- PROPOSED TEMPORARY TURNING EASEMENT.
- PROPOSED TEMPORARY ON-SITE STORM WATER BASIN.

APPL. NO. P23-01677 EXHIBIT A DATE 10/07/2024
 PLANNING REVIEW BY _____ DATE _____
 TRAFFIC ENG. _____ DATE _____
 APPROVED BY _____ DATE _____
CITY OF FRESNO DARM DEPT

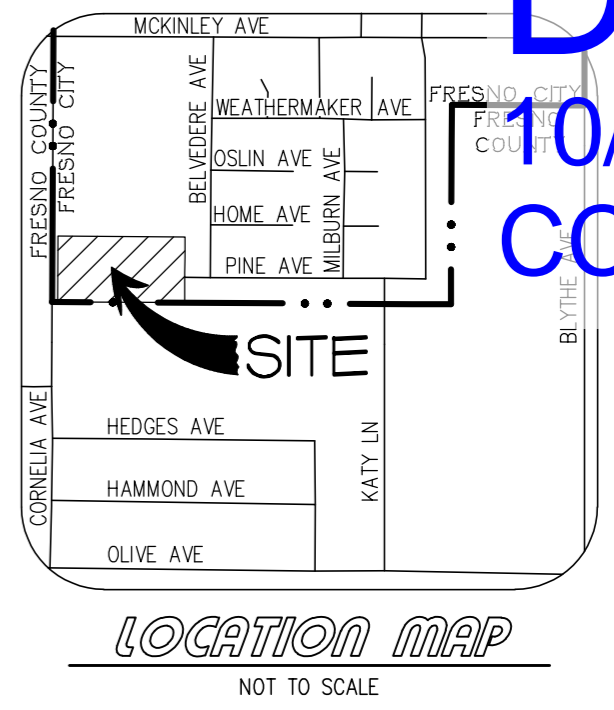

LEGAL DESCRIPTION:
 THE LAND DESCRIBED HEREIN IS SITUATED IN THE STATE OF CALIFORNIA, COUNTY OF FRESNO, CITY OF FRESNO, DESCRIBED AS FOLLOWS:
 THE SOUTH 326 FEET OF THE WEST ONE-HALF (W 1/2) OF THE NORTHWEST ONE-QUARTER (NW 1/4) OF THE NORTHWEST ONE-QUARTER (NW 1/4) OF SECTION 35, TOWNSHIP 13 SOUTH, RANGE 19 EAST, M.D.B. AND M., ACCORDING TO THE UNITED STATES GOVERNMENT TOWNSHIP PLATS.

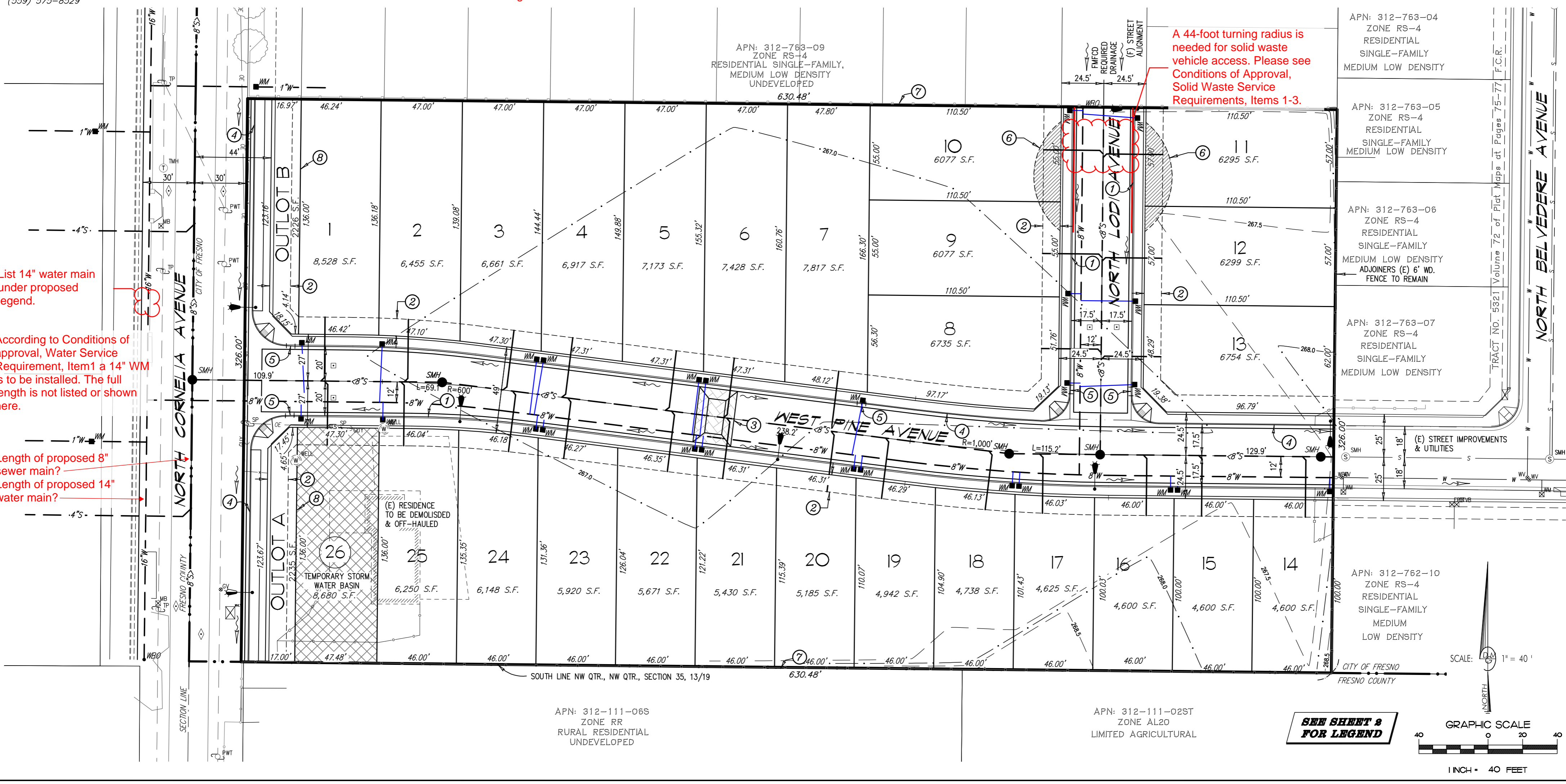

List 14" water main under proposed legend.
 According to Conditions of approval, Water Service Requirement, Item 1 a 14" WM is to be installed. The full length is not listed or shown here.
 Length of proposed 8" sewer main?
 Length of proposed 14" water main?

A 44-foot turning radius is needed for solid waste vehicle access. Please see Conditions of Approval, Solid Waste Service Requirements, Items 1-3.

SEE SHEET 2 FOR LEGEND

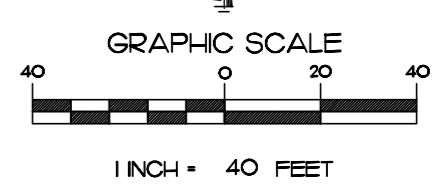

VESTING TENTATIVE TRACT MAP NO. 6399
"PINE VILLAS"
 BEING A PORTION OF SECTION 35, TOWNSHIP 13 SOUTH, RANGE 19 EAST, MOUNT DIABLO BASE & MERIDIAN

SITE LOCATION: 1732 N. CORNELIA AVE. FRESNO, CALIFORNIA
 ASSESSOR'S PARCEL NO. 312-763-10

PREPARED FOR:
SMS CONSTRUCTION
 280 SHAW AVE. SUITE B
 CLOVIS, CALIFORNIA 93612
 PHONE: 559-352-7617

PREPARED BY:
DALE G. MELL & ASSOCIATES
 ENGINEERING & SURVEYING SERVICES
 2090 NORTH WINERY AVENUE, FRESNO, CALIFORNIA 93703
 (559) 292-4046 • FAX 251-9220 • EMAIL: DGM@DALEGMELL.COM

PROFESSIONAL LAND SURVEYOR
 DALE G. MELL
 No. 4823
 STATE OF CALIFORNIA

JOB # 21-066
 DRAWN BY: DGM/JM
 CHECKED BY: JGM
 SCALE: 1" = 40'
 DATE: 08/23/21
 DWG # 21-066TTM
 FIELD BOOK: 477
 DATE OF SURVEY: 12/21/21
 LAST REVISED: 06/10/24

SHEET 1 OF 2

PLOTTED BY: DALE G. MELL - 5/30/2024 3:32:25 AM V:\PROJECTS\2021\PROJECTS\21-066\DWGS\21-066TTM.DWG

VESTING TENTATIVE TRACT MAP NO. 6397
"PINE VILLAS"
 BEING A PORTION OF SECTION 35
 TOWNSHIP 13 SOUTH, RANGE 10 EAST,
 MOUNT DIABLO BASE & MERIDIAN

SMS CONSTRUCTION
 280 SHAW AVE. SUITE B
 CLOVIS, CALIFORNIA 93612
 PHONE: 559-352-7617

DALE G. MELL
 & ASSOCIATES
 ENGINEERING & SURVEYING SERVICES
 2090 NORTH WAINWY AVE. FRESNO, CALIFORNIA 93703
 559.972.4616 • FAX 231.9220 • EMAIL: DGM@DGMELL.COM

PROFESSIONAL LAND SURVEYOR
 DALE G. MELL
 No. 4823
 STATE OF CALIFORNIA

JOB # 21-066
 DRAWN BY: DGM/JM
 CHECKED BY: DGM
 SCALE: 1" = 40'
 DATE: 08/23/21
 DWG # 21-066TTM
 FIELD BOOK: 477
 DATE OF SURVEY: 12/21/21
 LAST REVISED: 06/10/24

SHEET 2 OF 2

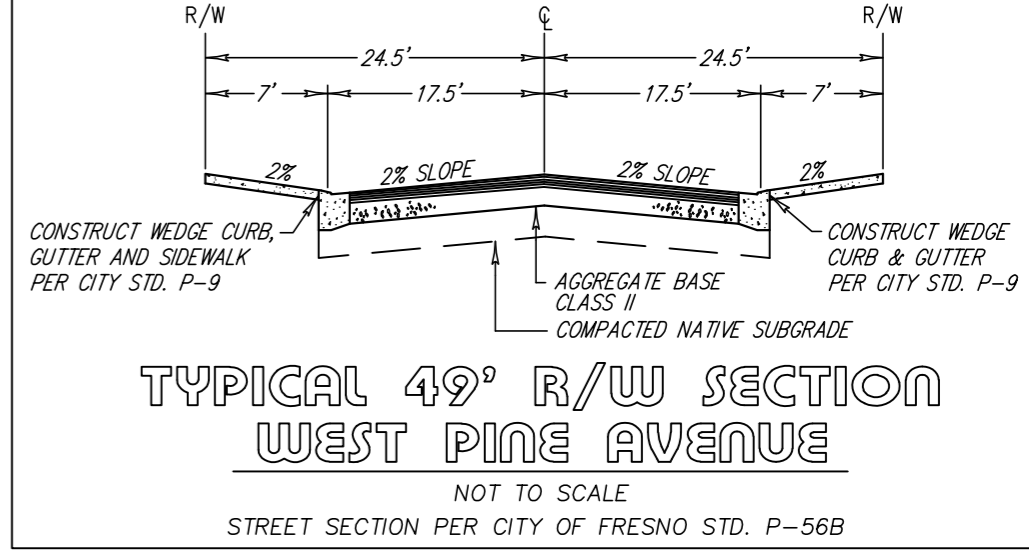
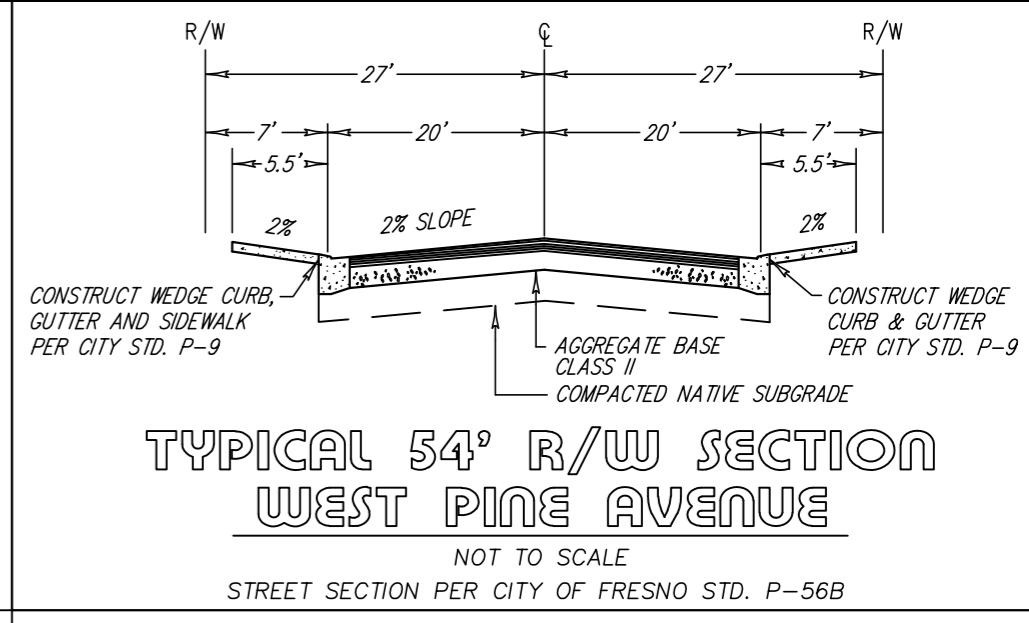
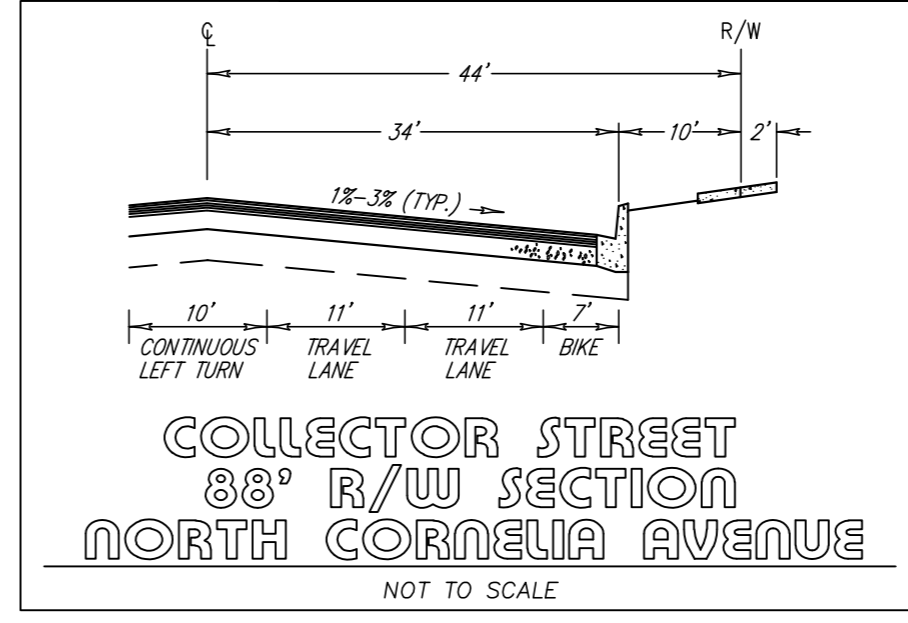
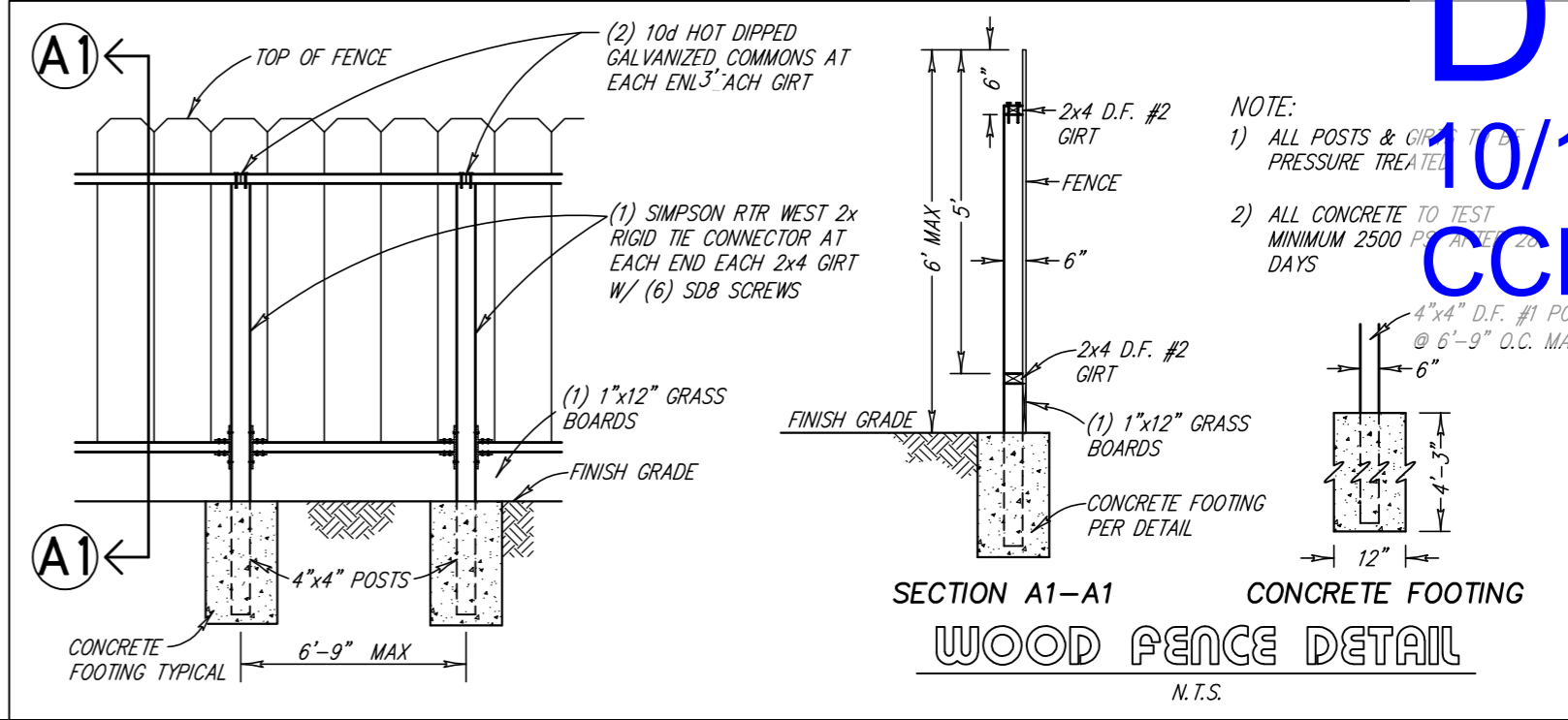
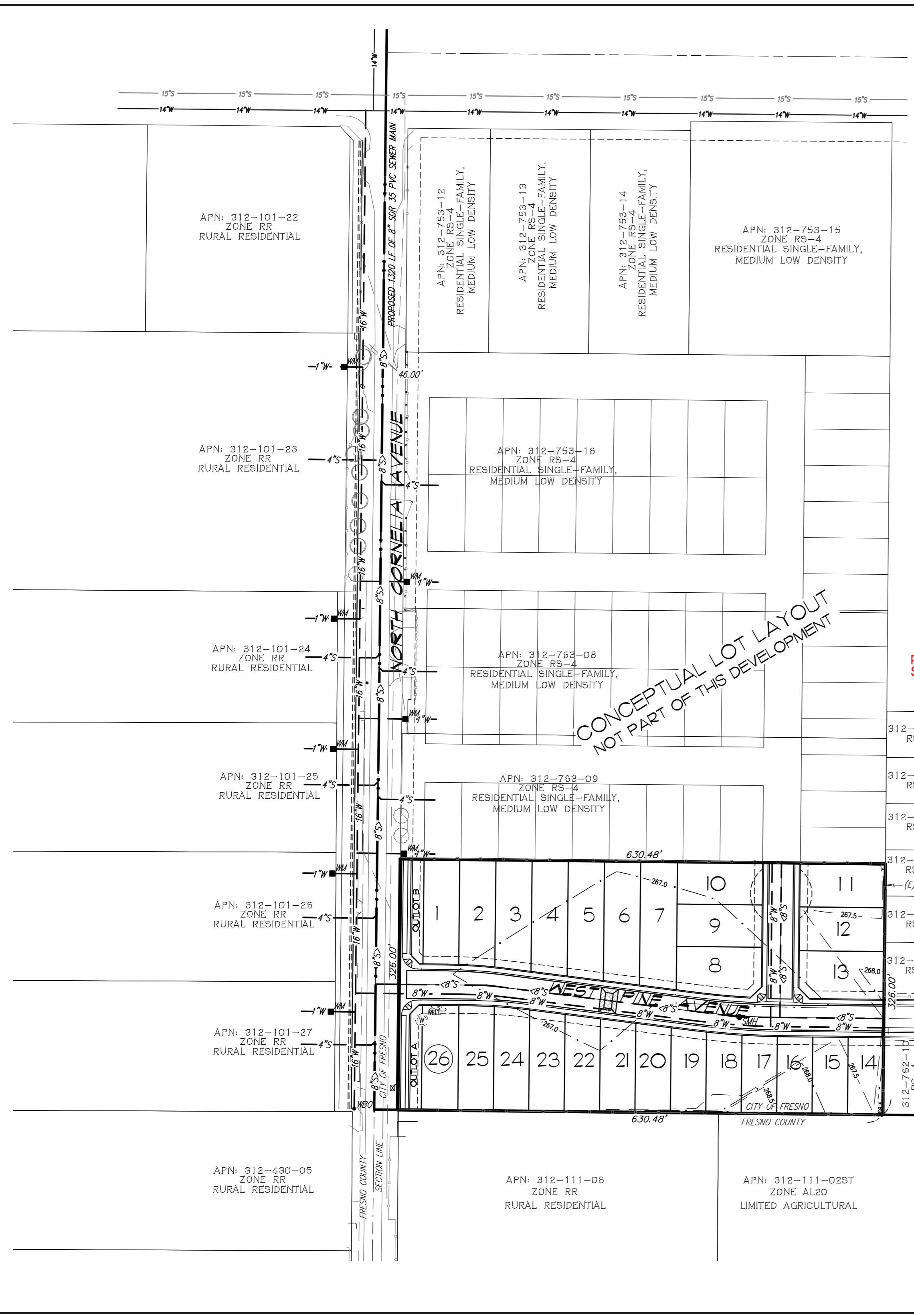

NOTES:
 1. 4" SEWER LATERALS & 1" WATER METERS TO BE INSTALLED ON EACH LOT FRONTING UTILITY IMPROVEMENTS

per City standards S1, S8, & S9

per City standards W-2

Length of proposed 8" sewer main?
 Length of proposed 16" water main?

APPL. NO. P23-01677 EXHIBIT A DATE 10/07/2024
 PLANNING REVIEW BY _____ DATE _____
 TRAFFIC ENG. _____ DATE _____
 APPROVED BY _____ DATE _____
CITY OF FRESNO DARM DEPT

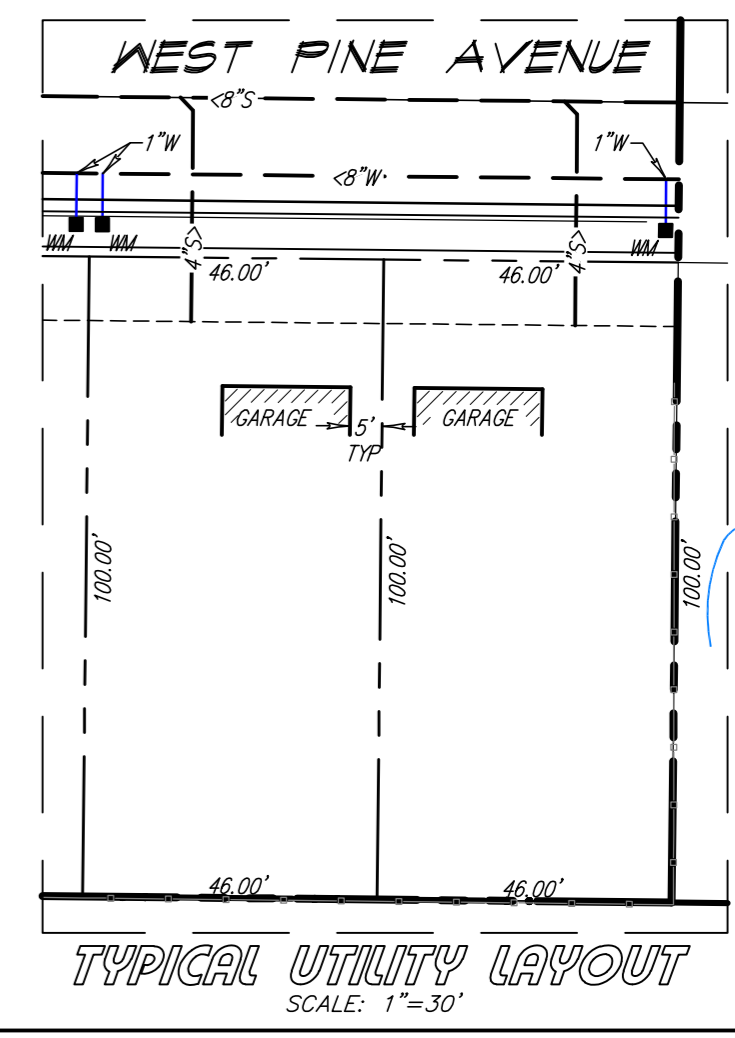
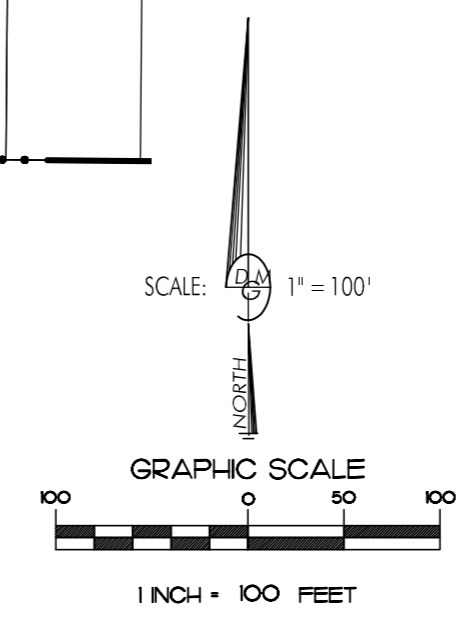

PLOTTED BY: DALE G. MELL - 5/20/2024 3:32:25 AM V:\PROJECTS\2021\PROJECTS\21-066\DWGS\21-066TTM.DWG

Fire Department

October 10, 2024

Comments

1. This is a proposed 26 lot subdivision with proposed 25-foot public streets. There are no relevant Public Works Standards for these streets shown on the map and these should be required to be placed on the map prior to any final approval of this map. FFD staff are unable to determine if there will be any on street parking restrictions.
2. This tract is within the 2-mile response distance from existing permanent Fire Station 16, and all lots are within the fire 4-minute response time. There are no development restrictions related to fire response.
3. Each lot proposed is subject to the city-wide fire protection impact fee paid to the Planning and Development Department. UGM Fee Requirements & Development restrictions related to fire services can be found in the Fresno Municipal Code.
4. All weather fire access must be provided, inspected and in service (approved) prior to the delivery of combustible material to the location. All weather fire access must be maintained throughout the project without interruption. FFD Policy #403.002.
5. No phasing of construction has been proposed by developer.
6. All street improvements to W. Pine, and N. Lodi, including all weather access to the tract entry points, must be maintained.
7. No fire hydrants are shown on this map and fire hydrant spacing must be updated, and compliant prior to any final approval of this map.
8. Install 8-inch minimum public water mains throughout the development per Public Utilities and Fire Department requirements for local residential streets. This map cannot be approved until the water main (leading south from W. McKinley) is installed in N. Cornelia and tied to the proposed 8" water main in W. Pine to achieve two points of connection.
9. This map cannot be approved until the 8" water main shown in N. Lodi has been connected with a second point of connection.
10. Provide public fire hydrants per Public Works and Public Utilities requirements for residential subdivisions with a minimum fire flow of 1500 gpm at a residual pressure of 20 psi with fire hydrants spaced no more than 600 feet apart with two points of connection.
11. Fire hydrants must be inspected and in service (approved) prior to the delivery of combustible material to the location.
12. There is no existing COF water main in Cornelia.
13. There is no existing COF water main which can connect to the proposed water main in W. Lodi.
14. Fire hydrants shall be in service, and two points of all-weather access provided and maintained during all stages of construction.
15. Dwelling units require an NFPA 13D residential fire sprinkler system supplied from the domestic water supply to each dwelling unit.
16. It is the permit applicant's obligation to confirm and comply with all fire & life safety provisions per '22 CFC §106.2.3



&
2600 Fresno Street
Fresno, California 93721-3604
www.fresno.gov

Fresno County Environmental Health

October 28, 2024

Comments

Recommended Conditions of Approval:

1. Construction permits for the proposed development should be subject to assurance of sewer capacity of the Regional Wastewater Treatment Facility. Concurrence should be obtained from the California Regional Water Quality Control Board (RWQCB). For more information, contact staff at (559) 445-5116.
2. Construction permits for the proposed development should be subject to assurance that the City of Fresno community water system has the capacity and quality to serve this project. Concurrence should be obtained from the State Water Resources Control Board, Division of Drinking Water-Southern Branch. For more information call (559) 447-3300.
3. The proposed construction project has the potential to expose nearby residents to elevated noise levels. Consideration should be given to your city's municipal code and the Fresno County Noise Ordinance.
4. Should any underground storage tank(s) be found during future projects, the applicant shall apply for and secure an Underground Storage Tank Removal Permit from the Fresno County Department of Public Health, Environmental Health Division. Contact the Fresno County Hazmat Compliance Program at (559) 600-3271 for more information.
5. As a measure to protect ground water, all water wells and/or septic systems that exist or have been abandoned within the project area should be properly destroyed by an appropriately licensed contractor.

**FRESNO METROPOLITAN FLOOD CONTROL DISTRICT
NOTICE OF REQUIREMENTS**

PUBLIC AGENCY

SAUL PEREZ
PLANNING & DEVELOPMENT DEPARTMENT
CITY OF FRESNO
2600 FRESNO STREET, THIRD FLOOR
FRESNO, CA 93721-3604

DEVELOPER

DALE G. MELL & ASSOCIATES
2090 N. WINERY AVE.
FRESNO, CA 93703

PROJECT NO: **6397**

ADDRESS: **1732 N. CORNELIA AVE.**

APN: **312-763-10**

SENT: **October 31, 2024**

Drainage Area(s)	Preliminary Fee(s)	Development Review Service Charge(s)	Fee(s)	
AN	\$46,211.00	NOR Review	\$212.00	To be paid prior to release of District comments to Public Agency and Developer.
		Grading Plan Review	\$593.00	Amount to be submitted with first grading plan submittal.
Total Drainage Fee: \$46,211.00		Total Service Charge: \$805.00		

The proposed development will generate storm runoff which produces potentially significant environmental impacts and which must be properly discharged and mitigated pursuant to the California Environmental Quality Act and the National Environmental Policy Act. The District in cooperation with the City and County has developed and adopted the Storm Drainage and Flood Control Master Plan. Compliance with and implementation of this Master Plan by this development project will satisfy the drainage related CEQA/NEPA impact of the project mitigation requirements.

Pursuant to the District’s Development Review Fee Policy, the subject project shall pay review fees for issuance of this Notice of Requirements (NOR) and any plan submittals requiring the District’s reviews. The NOR fee shall be paid to the District by Developer before the Notice of Requirement will be submitted to the City. The Grading Plan fee shall be paid upon first submittal. The Storm Drain Plan fee shall be paid prior to return/pick up of first submittal.

The proposed development shall pay drainage fees pursuant to the Drainage Fee Ordinance prior to issuance of a building permit at the rates in effect at the time of such issuance. The fee indicated above is valid through 2/28/25 based on the site plan submitted to the District on 10/07/24 Contact FMFCD for a revised fee in cases where changes are made in the proposed site plan which materially alter the proposed impervious area.

Considerations which may affect the fee obligation(s) or the timing or form of fee payment:

- a.) Fees related to undeveloped or phased portions of the project may be deferrable.
- b.) Fees may be calculated based on the actual percentage of runoff if different than that typical for the zone district under which the development is being undertaken and if permanent provisions are made to assure that the site remains in that configuration.
- c.) Creditable storm drainage facilities may be constructed, or required to be constructed in lieu of paying fees.
- d.) The actual cost incurred in constructing Creditable drainage system facilities is credited against the drainage fee obligation.
- e.) When the actual costs incurred in constructing Creditable facilities exceeds the drainage fee obligation, reimbursement will be made for the excess costs from future fees collected by the District from other development.
- f.) Any request for a drainage fee refund requires the entitlement cancellation and a written request addressed to the General Manager of the District within 60 days from payment of the fee. A non refundable \$300 Administration fee or 5% of the refund whichever is less will be retained without fee credit.

FR TRACT No. 6397

FRESNO METROPOLITAN FLOOD CONTROL DISTRICT
NOTICE OF REQUIREMENTS

Page 2 of 4

FR TRACT No. 6397

Approval of this development shall be conditioned upon compliance with these District Requirements.

1. a. Drainage from the site shall
 b. Grading and drainage patterns shall be as identified on Exhibit No. 1.
 c. The grading and drainage patterns shown on the site plan conform to the adopted Storm Drainage and Flood Control Master Plan.

2. The proposed development shall construct and/or dedicate Storm Drainage and Flood Control Master Plan facilities located within the development or necessitated by any off-site improvements required by the approving agency:
 Developer shall construct facilities as shown on Exhibit No. 1 as MASTER PLAN FACILITIES TO BE CONSTRUCTED BY DEVELOPER.
 None required.

3. The following final improvement plans and information shall be submitted to the District for review prior to final development approval:
 Grading Plan
 Street Plan
 Storm Drain Plan
 Water & Sewer Plan
 Final Map
 Drainage Report (to be submitted with tentative map)
 Other
 None Required

4. Availability of drainage facilities:
 a. Permanent drainage service is available provided the developer can verify to the satisfaction of the City that runoff can be safely conveyed to the Master Plan inlet(s).
 b. The construction of facilities required by Paragraph No. 2 hereof will provide permanent drainage service.
 c. Permanent drainage service will not be available. The District recommends temporary facilities until permanent service is available.
 d. See Exhibit No. 2.

5. The proposed development:
 Appears to be located within a 100 year flood prone area as designated on the latest Flood Insurance Rate Maps available to the District, necessitating appropriate floodplain management action. (See attached Floodplain Policy.)
 Does not appear to be located within a flood prone area.

6. The subject site contains a portion of a canal or pipeline that is used to manage recharge, storm water, and/or flood flows. The existing capacity must be preserved as part of site development. Additionally, site development may not interfere with the ability to operate and maintain the canal or pipeline.

FRESNO METROPOLITAN FLOOD CONTROL DISTRICT
NOTICE OF REQUIREMENTS

Page 3 of 4

FR
TRACT
No. 6397

7. The Federal Clean Water Act and the State General Permits for Storm Water Discharges Associated with Construction and Industrial Activities (State General Permits) require developers of construction projects disturbing one or more acres, and discharges associated with industrial activity not otherwise exempt from National Pollutant Discharge Elimination System (NPDES) permitting, to implement controls to reduce pollutants, prohibit the discharge of waters other than storm water to the municipal storm drain system, and meet water quality standards. These requirements apply both to pollutants generated during construction, and to those which may be generated by operations at the development after construction.
- a. State General Permit for Storm Water Discharges Associated with Construction Activities, effective July 1, 2010, as amended. A State General Construction Permit is required for all clearing, grading, and disturbances to the ground that result in soil disturbance of at least one acre (or less than one acre) if part of a larger common plan of development or sale). Permittees are required to: submit a Notice of Intent and Permit Registration Documents to be covered and must pay a permit fee to the State Water Resources Control Board (State Board), develop and implement a storm water pollution prevention plan, eliminate non-storm water discharges, conduct routine site inspections, train employees in permit compliance, and complete an annual certification of compliance.
 - b. State General Permit for Storm Water Discharges Associated with Industrial Activities, April, 2014 (available at the District Office). A State General Industrial Permit is required for specific types of industries described in the NPDES regulations or by Standard Industrial Classification (SIC) code. The following categories of industries are generally required to secure an industrial permit: manufacturing; trucking; recycling; and waste and hazardous waste management. Specific exemptions exist for manufacturing activities which occur entirely indoors. Permittees are required to: submit a Notice of Intent to be covered and must pay a permit fee to the State Water Resources Control Board, develop and implement a storm water pollution prevention plan, eliminate non-storm water discharges, conduct routine site inspections, train employees in permit compliance, sample storm water runoff and test it for pollutant indicators, and annually submit a report to the State Board.
 - c. The proposed development is encouraged to select and implement storm water quality controls recommended in the Fresno-Clovis Storm Water Quality Management Construction and Post-Construction Guidelines (available at the District Office) to meet the requirements of the State General Permits, eliminate the potential for non-storm water to enter the municipal storm drain system, and where possible minimize contact with materials which may contaminate storm water runoff.
8. A requirement of the District may be appealed by filing a written notice of appeal with the Secretary of the District within ten days of the date of this Notice of Requirements.
9. The District reserves the right to modify, reduce or add to these requirements, or revise fees, as necessary to accommodate changes made in the proposed development by the developer or requirements made by other agencies.
10. X See Exhibit No. 2 for additional comments, recommendations and requirements.



Brent Sunamoto
District Engineer, RCE

Digitally signed by Brent Sunamoto Date: 10/31/2024 8:16:35 AM



David L. Everitt
Engineering Technician I

Digitally signed by David L. Everitt Date: 10/23/2024 3:19:07 PM

**FRESNO METROPOLITAN FLOOD CONTROL DISTRICT
NOTICE OF REQUIREMENTS**

Page 4 of 4

CC:

LADHAR MANREET SINGH

280 SHAW AVE. SUITE B

CLOVIS, CA 93612

RENU VAGARWAL, SMS CONSTRUCTION SERVICES

270 SHAW AVE. SUITE 119

CLOVIS, CA 93711

FR TRACT No. 6397

NOTE: THIS MAP IS SCHEMATIC. DISTANCES, AMOUNT OF CREDITABLE FACILITIES, AND LOCATION OF INLET BOUNDARIES ARE APPROXIMATE.

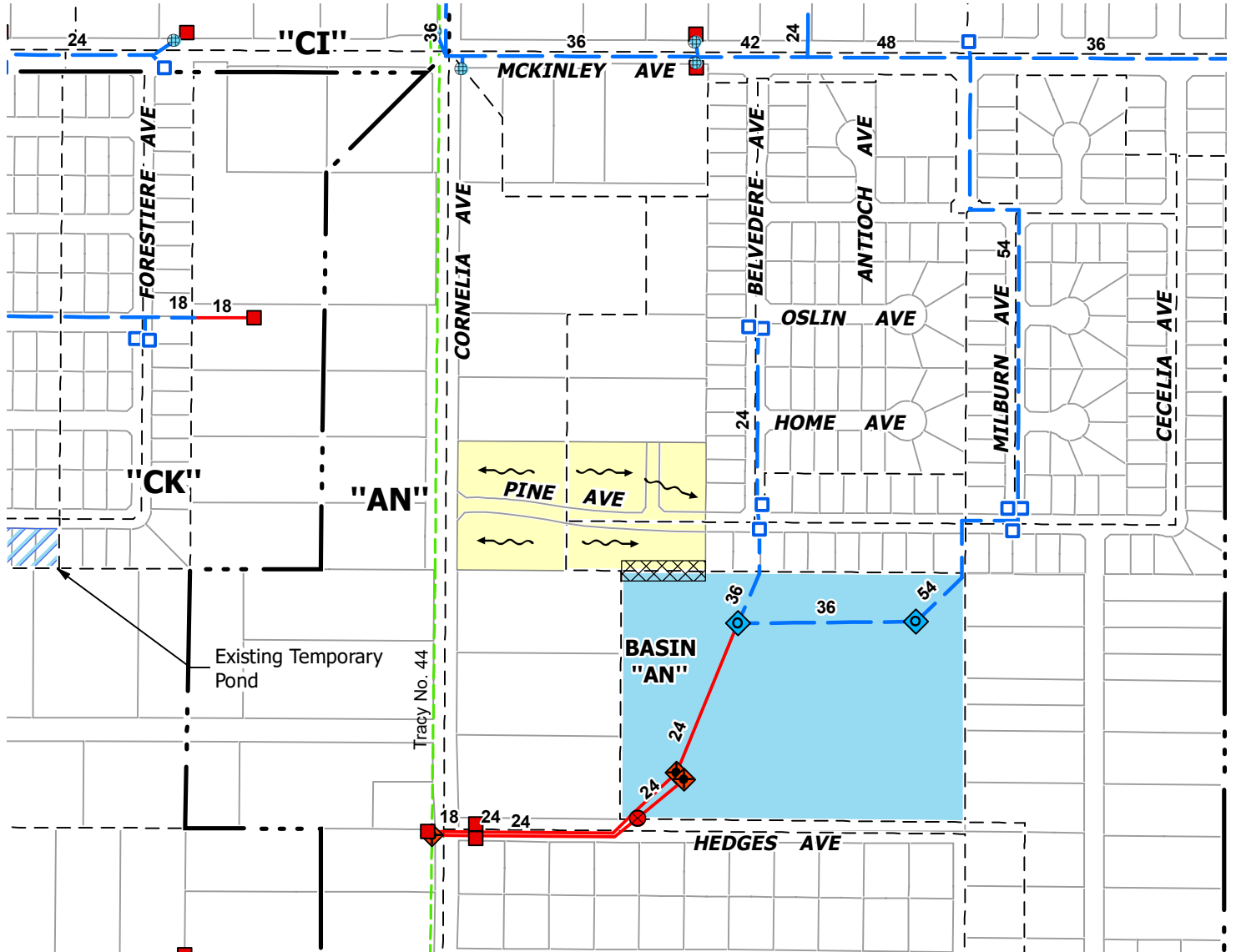

LEGEND

- Existing Master Plan Facilities
- Future Master Plan Facilities
- Inlet Boundary
- Drainage Area Boundary
- Direction Of Drainage
- Existing Temporary Inlet
- Existing Master Plan Outfall
- Future Master Plan Outfall
- Future Master Plan Pump Station
- Existing FID Facilities
- Master Plan Facilities To Be Constructed By Developer - Mowstrip
- Limits Of TRACT 6397



1" = 407'

TRACT 6397 DRAINAGE AREA "AN"

EXHIBIT NO. 1

FRESNO METROPOLITAN FLOOD CONTROL DISTRICT



OTHER REQUIREMENTS

EXHIBIT NO. 2

The cost of construction of Master Plan facilities, excluding dedication of storm drainage easements, is eligible for credit against the drainage fee of the drainage area served by the facilities. A Development Agreement shall be executed with the District to effect such credit. Reimbursement provisions, in accordance with the Drainage Fee Ordinance, will be included to the extent that developer's Master Plan costs for an individual drainage area exceed the fee of said area. Should the facilities cost for such individual area total less than the fee of said area, the difference shall be paid upon demand to the City or District.

No surface runoff shall be directed towards the District basin. The District requests that the grading Engineer contact the District as early as possible to review the proposed site grading for verification and acceptance of grades at our mutual property line prior to preparing a grading plan.

The District recommends a single fence between the site and the District's basin. The developer should contact the District so that alternatives to a dual fence can be reviewed. If a fence other than the existing chain link fence is proposed, District review and approval of the proposed fence is required.

Permanent drainage service is available to that portion of Tract 6397 that drains to the east as shown on Exhibit No. 1. The portion of Tract 6397 that drains to the west to Cornelia Avenue will not have permanent service. The District recommends temporary facilities for the western portion until permanent service is available.

The Master Plan system has been designed such that during a two-year event flow will not exceed the height of the 6-inch curb. Should wedge curb (4.5 inches height) be used the same criteria shall apply whereby flow remains below the top of curb. Any extensions or pipe size increases due to meeting the requirement listed above shall be at the developer's expense.

Lot coverage must be provided to the District prior to submittal of improvement plans. The final drainage fee will be calculated commensurate with the lot coverage provided by the developer. If the lot coverage indicates a density higher than Master Planned, mitigation may be required. The lot coverage calculated by the District includes the front yard walkway, sidewalk walkway and the rear yard patio equaling an additional 6% of impervious area in addition to the City's typical lot coverage calculation.



2907 S. Maple Avenue
Fresno, California 93725-2208
Telephone: (559) 233-7161
Fax: (559) 233-8227

CONVEYANCE. COMMITMENT. CUSTOMER SERVICE.

October 17, 2024

Saul Perez
Development & Resource Management
City of Fresno
2600 Fresno Street, Third Floor
Fresno, CA 93721

RE: Tentative Tract Map Application No. P23-01677, Tract 6397
S/E McKinley and Cornelia avenues

Dear Mr. Perez:

The Fresno Irrigation District (FID) has reviewed Tentative Tract Map Application No. P23-01677 for which the applicant proposes to subdivide the subject property into a 26-lot single-family residential subdivision, APN: 312-763-10. FID has the following comments:

1. FID does not own, operate, or maintain any facilities located on the subject property, as shown on the attached FID exhibit map.
2. For informational purposes, FID's active Tracy No. 44 runs southerly along the west side of Cornelia Avenue approximately 50 feet west of the subject property, and crosses McKinley Avenue approximately 970 feet north of the subject property, as shown on the attached FID exhibit map. Should this project include any street and/or utility improvements along Cornelia Avenue, McKinley Avenue, or in the vicinity of this facility, FID requires it review and approve all plans.
3. FID is concerned that the proposed development may negatively impact local groundwater supplies. The area is currently open land with minimal to no water use. Under current circumstances the project area is experiencing a modest but continuing groundwater overdraft. FID recommends the City of Fresno require the proposed development balance anticipated groundwater use with sufficient recharge of imported surface water in order to preclude increasing the area's existing groundwater overdraft problem.

G:\Agencies\FresnoCity\Tract Map\P23-01677 - TM6397\6397, P23-01677 FID Comments.doc

BOARD OF DIRECTORS

President RYAN JACOBSEN Vice-President JERRY PRIETO, JR. CHRISTOPHER WOOLF
GEORGE PORTER GREGORY BEBERIAN General Manager BILL STRETCH

4. California enacted landmark legislation in 2014 known as the Sustainable Groundwater Management Act (SGMA). The act requires the formation of local groundwater sustainability agencies (GSAs) that must assess conditions in their local water basins and adopt locally-based management plans. FID and the City of Fresno are members of the North Kings Groundwater Sustainability Agency which will manage the groundwater basin within the FID service area. This area is completely reliant on groundwater pumping and SGMA will impact all users of groundwater and those who rely on it. The City of Fresno should consider the impacts of the development on the City's ability to comply with requirements of SGMA.

Thank you for submitting this for our review. We appreciate the opportunity to review and comment on the subject documents for the proposed project. If you have any questions, please feel free to contact Chris Lundeen at (559) 233-7161 extension 7410 or clundeen@fresnoirrigation.com.

Sincerely,



Laurence Kimura, P.E.
Chief Engineer

Attachment

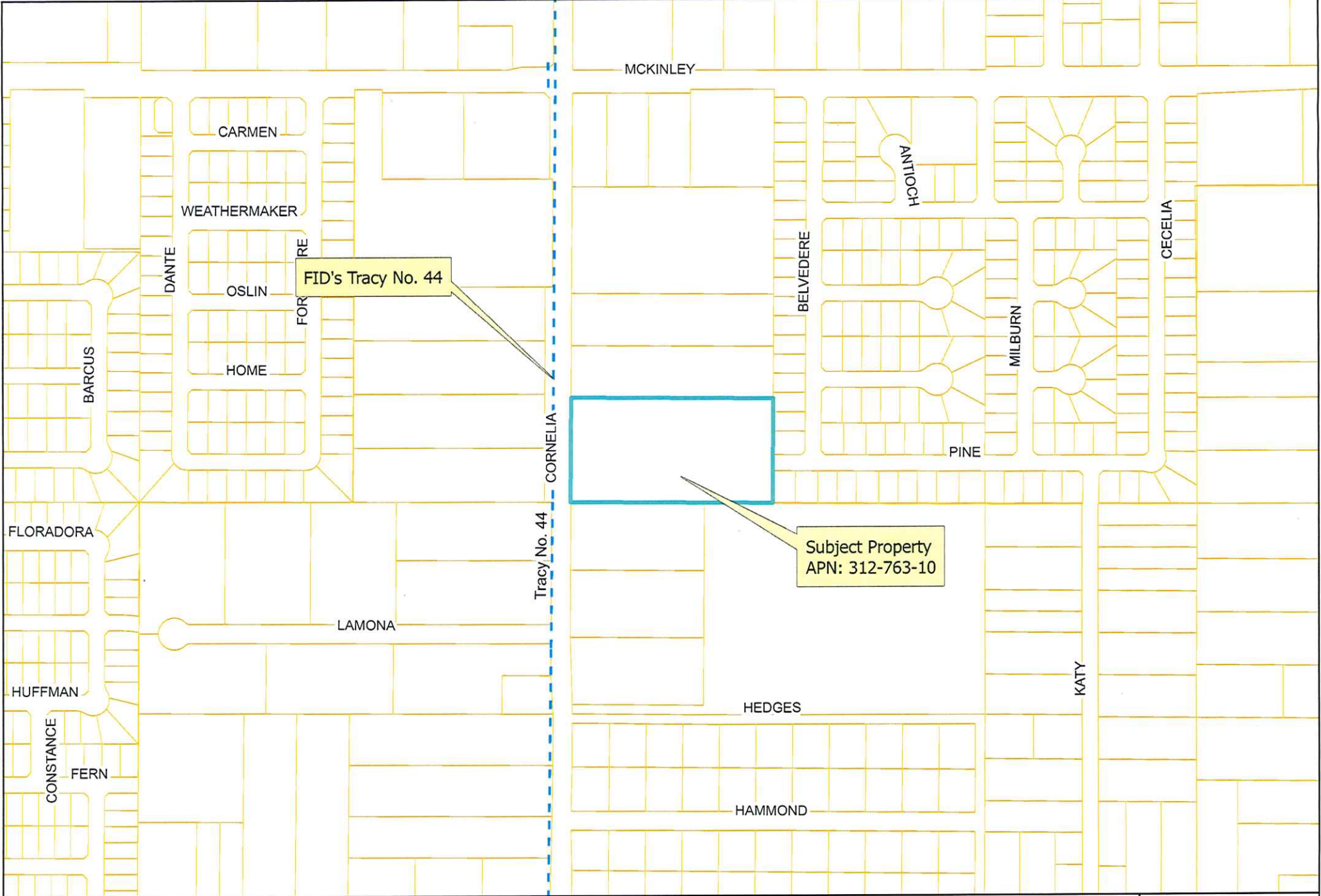

Legend			
FID Canal	FID Pipeline	Stream Group	FID Boundary
Private Canal	Private Pipeline	Other-Creek/River	Railroad
Abandoned Canal	Abandoned Pipeline	Other-Pipeline	Streets & Hwys
		Parcel	FMFCD Acquired Basins
			FMFCD Proposed Basins

This map was produced by the Fresno Irrigation District and is provided for reference and informational purposes only and is not intended to show map scale accuracy or all inclusive map features, nor for legal purposes. FID makes no statements regarding the accuracy of this map as the features shown are in their approximate location. Please contact the FID Engineering Dept. at (559) 233-7161 for further information on FID facilities.

Spatial Reference:
Name: NAD 1983 StatePlane California IV FIPS 0404

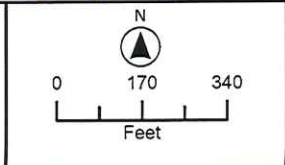

October 25, 2024

Saul Perez
City of Fresno
Planning Department
2600 Fresno Street, No. 3043
Fresno, CA 93721

Project: Tentative Tract Map No. 6397 – P23-01677

District CEQA Reference No: 20241154

Dear Mr. Perez:

The San Joaquin Valley Air Pollution Control District (District) has reviewed the tentative tract map (TTM) from the City of Fresno (City) for the residential development project. Per the TTM, the project consists of 26 single-family homes (Project). The Project is located 1732 N. Cornelia Avenue in Fresno, CA.

The District offers the following comments at this time regarding the Project:

1) Project Related Emissions

At the federal level under the National Ambient Air Quality Standards (NAAQS), the District is designated as extreme nonattainment for the 8-hour ozone standards and serious nonattainment for the particulate matter less than 2.5 microns in size (PM2.5) standards. At the state level under California Ambient Air Quality Standards (CAAQS), the District is designated as nonattainment for the 8-hour ozone, PM10, and PM2.5 standards.

Based on information provided to the District, Project specific annual criteria pollutant emissions from construction and operation are not expected to exceed any of the significance thresholds as identified in the District's Guidance for Assessing and Mitigating Air Quality Impacts (GAMAQI):

<https://ww2.valleyair.org/media/g4nl3p0g/gamaqi.pdf>.

Samir Sheikh
Executive Director/Air Pollution Control Officer

Northern Region
4800 Enterprise Way
Modesto, CA 95356-8718
Tel: (209) 557-6400 FAX: (209) 557-6475

Central Region (Main Office)
1990 E. Gettysburg Avenue
Fresno, CA 93726-0244
Tel: (559) 230-6000 FAX: (559) 230-6061

Southern Region
34946 Flyover Court
Bakersfield, CA 93308-9725
Tel: (661) 392-5500 FAX: (661) 392-5585

1a) Construction Emissions

The District recommends, to reduce impacts from construction-related diesel exhaust emissions, the Project should utilize the cleanest available off-road construction equipment.

2) Health Risk Screening/Assessment

The City should evaluate the risk associated with the Project for sensitive receptors (residences, businesses, hospitals, day-care facilities, health care facilities, etc.) in the area and mitigate any potentially significant risk to help limit exposure of sensitive receptors to emissions.

To determine potential health impacts on surrounding receptors (residences, businesses, hospitals, day-care facilities, health care facilities, etc.) a Prioritization and/or a Health Risk Assessment (HRA) should be performed for the Project. These health risk determinations should quantify and characterize potential Toxic Air Contaminants (TACs) identified by the Office of Environmental Health Hazard Assessment/California Air Resources Board (OEHHA/CARB) that pose a present or potential hazard to human health.

Health risk analyses should include all potential air emissions from the project, which include emissions from construction of the project, including multi-year construction, as well as ongoing operational activities of the project. Note, two common sources of TACs can be attributed to diesel exhaust emitted from heavy-duty off-road earth moving equipment during construction, and from ongoing operation of heavy-duty on-road trucks.

Prioritization (Screening Health Risk Assessment):

A "Prioritization" is the recommended method for a conservative screening-level health risk assessment. The Prioritization should be performed using the California Air Pollution Control Officers Association's (CAPCOA) methodology. Please contact the District for assistance with performing a Prioritization analysis.

The District recommends that a more refined analysis, in the form of an HRA, be performed for any project resulting in a Prioritization score of 10 or greater. This is because the prioritization results are a conservative health risk representation, while the detailed HRA provides a more accurate health risk evaluation.

Health Risk Assessment:

Prior to performing an HRA, it is strongly recommended that land use agencies/ project proponents develop and submit for District review a health risk modeling protocol that outlines the sources and methodologies that will be used to perform the HRA.

A development project would be considered to have a potentially significant health risk if the HRA demonstrates that the health impacts would exceed the District's established risk thresholds, which can be found here:

<https://ww2.valleyair.org/permitting/ceqa/>.

A project with a significant health risk would trigger all feasible mitigation measures. The District strongly recommends that development projects that result in a significant health risk not be approved by the land use agency.

The District is available to review HRA protocols and analyses. For HRA submittals please provide the following information electronically to the District for review:

- HRA (AERMOD) modeling files
- HARP2 files
- Summary of emissions source locations, emissions rates, and emission factor calculations and methodologies.

For assistance, please contact the District's Technical Services Department by:

- E-Mailing inquiries to: hramodeler@valleyair.org
- Calling (559) 230-5900

Recommended Measure: Development projects resulting in TAC emissions should be located an adequate distance from residential areas and other sensitive receptors to prevent the creation of a significant health risk in accordance to CARB's Air Quality and Land Use Handbook: A Community Health Perspective located at <https://ww2.arb.ca.gov/our-work/programs/resource-center/strategy-development/land-use-resources>.

3) Vegetative Barriers and Urban Greening

There are residential units located in all directions within close proximity of the Project. The District suggests the City consider the feasibility of incorporating vegetative barriers and urban greening as a measure to further reduce air pollution exposure on sensitive receptors (e.g., residential units).

While various emission control techniques and programs exist to reduce air quality emissions from mobile and stationary sources, vegetative barriers have been shown to be an additional measure to potentially reduce a population's exposure to air pollution through the interception of airborne particles and the uptake of gaseous pollutants. Examples of vegetative barriers include, but are not limited to the following: trees, bushes, shrubs, or a mix of these. Generally, a higher and thicker vegetative barrier with full coverage will result in greater reductions in downwind pollutant concentrations. In the same manner, urban greening is also a way to help

improve air quality and public health in addition to enhancing the overall beautification of a community with drought tolerant, low-maintenance greenery.

4) Clean Lawn and Garden Equipment in the Community

Since the Project consists of residential development, gas-powered residential lawn and garden equipment have the potential to result in an increase of NOx and PM2.5 emissions. Utilizing electric lawn care equipment can provide residents with immediate economic, environmental, and health benefits. The District recommends the Project proponent consider the District's Clean Green Yard Machines (CGYM) program which provides incentive funding for replacement of existing gas powered lawn and garden equipment. More information on the District CGYM program and funding can be found at: <https://ww2.valleyair.org/grants/clean-green-yard-machines-residential/> and <https://ww2.valleyair.org/grants/zero-emission-landscaping-equipment-voucher-program/>.

5) On-Site Solar Deployment

It is the policy of the State of California that renewable energy resources and zero-carbon resources supply 100% of retail sales of electricity to California end-use customers by December 31, 2045. While various emission control techniques and programs exist to reduce air quality emissions from mobile and stationary sources, the production of solar energy is contributing to improving air quality and public health. The District suggests that the City consider incorporating solar power systems as an emission reduction strategy for the Project.

6) District Rules and Regulations

The District issues permits for many types of air pollution sources, and regulates some activities that do not require permits. A project subject to District rules and regulations would reduce its impacts on air quality through compliance with the District's regulatory framework. In general, a regulation is a collection of individual rules, each of which deals with a specific topic. As an example, Regulation II (Permits) includes District Rule 2010 (Permits Required), Rule 2201 (New and Modified Stationary Source Review), Rule 2520 (Federally Mandated Operating Permits), and several other rules pertaining to District permitting requirements and processes.

The list of rules below is neither exhaustive nor exclusive. Current District rules can be found online at: <https://ww2.valleyair.org/rules-and-planning/current-district-rules-and-regulations>. To identify other District rules or regulations that apply to future projects, or to obtain information about District permit requirements, the project proponents are strongly encouraged to contact the District's Small Business Assistance (SBA) Office at (559) 230-5888.

6a) District Rules 2010 and 2201 - Air Quality Permitting for Stationary Sources

Stationary Source emissions include any building, structure, facility, or installation which emits or may emit any affected pollutant directly or as a fugitive emission. District Rule 2010 (Permits Required) requires operators of emission sources to obtain an Authority to Construct (ATC) and Permit to Operate (PTO) from the District. District Rule 2201 (New and Modified Stationary Source Review) requires that new and modified stationary sources of emissions mitigate their emissions using Best Available Control Technology (BACT).

This Project may be subject to District Rule 2010 (Permits Required) and Rule 2201 (New and Modified Stationary Source Review) and may require District permits. Prior to construction, the Project proponent should submit to the District an application for an ATC. For further information or assistance, the project proponent may contact the District's SBA Office at (559) 230-5888.

6b) District Rule 9510 - Indirect Source Review (ISR)

The District has reviewed the information provided and has determined the project size is below the District Rule 9510, section 2.1 applicability threshold of 50 dwelling units for a residential development. Therefore, District Rule 9510 requirements and related fees do not apply to the project.

6c) District Rule 9410 (Employer Based Trip Reduction)

The Project may be subject to District Rule 9410 (Employer Based Trip Reduction) if the project would result in employment of 100 or more "eligible" employees. District Rule 9410 requires employers with 100 or more "eligible" employees at a worksite to establish an Employer Trip Reduction Implementation Plan (eTRIP) that encourages employees to reduce single-occupancy vehicle trips, thus reducing pollutant emissions associated with work commutes. Under an eTRIP plan, employers have the flexibility to select the options that work best for their worksites and their employees.

Information about District Rule 9410 can be found online at:
<https://ww2.valleyair.org/compliance/rule-9410-employer-based-trip-reduction/>.

For additional information, you can contact the District by phone at 559-230-6000 or by e-mail at etrip@valleyair.org

6d) District Rule 4002 (National Emissions Standards for Hazardous Air Pollutants)

In the event an existing building will be renovated, partially demolished or removed, the Project may be subject to District Rule 4002. This rule requires a thorough inspection for asbestos to be conducted before any regulated facility is demolished or renovated. Information on how to comply with District Rule 4002 can be found online at: <https://ww2.valleyair.org/compliance/demolition-renovation/>

6e) District Rule 4601 (Architectural Coatings)

The Project will be subject to District Rule 4601 since it is expected to utilize architectural coatings. Architectural coatings are paints, varnishes, sealers, or stains that are applied to structures, portable buildings, pavements or curbs. The purpose of this rule is to limit VOC emissions from architectural coatings. In addition, this rule specifies architectural coatings storage, cleanup and labeling requirements. Additional information on how to comply with District Rule 4601 requirements can be found online at: <https://ww2.valleyair.org/media/tkgjeusd/rule-4601.pdf>

6f) District Regulation VIII (Fugitive PM10 Prohibitions)

The project proponent may be required to submit a Construction Notification Form or submit and receive approval of a Dust Control Plan prior to commencing any earthmoving activities as described in Regulation VIII, specifically Rule 8021 – *Construction, Demolition, Excavation, Extraction, and Other Earthmoving Activities*.

Should the project result in at least 1-acre in size, the project proponent shall provide written notification to the District at least 48 hours prior to the project proponents intent to commence any earthmoving activities pursuant to District Rule 8021 (Construction, Demolition, Excavation, Extraction, and Other Earthmoving Activities). Also, should the project result in the disturbance of 5-acres or more, or will include moving, depositing, or relocating more than 2,500 cubic yards per day of bulk materials, the project proponent shall submit to the District a Dust Control Plan pursuant to District Rule 8021 (Construction, Demolition, Excavation, Extraction, and Other Earthmoving Activities). For additional information regarding the written notification or Dust Control Plan requirements, please contact District Compliance staff at (559) 230-5950.

The application for both the Construction Notification and Dust Control Plan can be found online at: <https://ww2.valleyair.org/media/fm3jrbsq/dcp-form.docx>

Information about District Regulation VIII can be found online at:
<https://ww2.valleyair.org/dustcontrol>

6g) District Rule 4901 - Wood Burning Fireplaces and Heaters

The purpose of this rule is to limit emissions of carbon monoxide and particulate matter from wood burning fireplaces, wood burning heaters, and outdoor wood burning devices. This rule establishes limitations on the installation of new wood burning fireplaces and wood burning heaters. Specifically, at elevations below 3,000 feet in areas with natural gas service, no person shall install a wood burning fireplace, low mass fireplace, masonry heater, or wood burning heater.

Information about District Rule 4901 can be found online at:
<https://ww2.valleyair.org/compliance/residential-wood-smoke-reduction-program/>

6h) Other District Rules and Regulations

The Project may also be subject to the following District rules: Rule 4641 (Cutback, Slow Cure, and Emulsified Asphalt, Paving and Maintenance Operations).

7) District Comment Letter

The District recommends that a copy of the District's comments be provided to the Project proponent.

If you have any questions or require further information, please contact Jacob Torrez by e-mail at jacob.torrez@valleyair.org or by phone at (559) 230-6558.

Sincerely,

Tom Jordan
Director of Policy and Government Affairs



For: Mark Montelongo
Program Manager



&
2600 Fresno Street
Fresno, California 93721-3604
www.fresno.gov

Central Unified School District

October 28, 2024

Comments

This is in response to Planned Development Application No. P23-01677, in which the applicant requests to subdivide the property located on the east side of North Cornelia Avenue, Between West McKinley and West Hedges Avenue, into 26 single-family lots.

The District has reviewed the request regarding the above-referenced development and has no intention of pursuing this property for a school site in our Facilities Master Plan.

The proposed development will produce 26 single-family dwelling units. The current accumulated student generation rate for Central Unified School District is approximately 0.52. The breakdown for grade level is as follows:

26 Single Family:

Grade level: TK - 6 Units: 26, Student Generation Rate: 0.33, Students generated: 8.58, School of Attendance: Herndon Barstow/ Harvest Elementary.

Grade level: 7-8, Units: 26 Students Generation Rate: 0.05, Students generated: 1.30, School of Attendance: Glacier Point Middle School.

Grade level: 9-12, Units: 236, Students Generation Rate: 0.14, Students generated: 3.64, School of Attendance: Justin Garza High School.

The 26 single-family homes and the District's 0.52 current student generation rate will produce approximately 14 students. Of the 14 students, nine will be in the TK-6 grade level, one will be in the 7-8 grade level, and Four will be in the 9-12 grade level. With the District's current attendance area boundaries, students from this development will attend McKinley Elementary, El Capitan Middle School, and Central High School. Attendance area boundaries are utilized to balance enrollment and are, therefore, subject to change.

Due to the increased traffic that this development would create, there would be an urgent need to provide our students who walk to school with safety support improvements such as High-Intensity Activated Crosswalk (H.A.W.K.) systems, street lights, signal lights, and road widening, along the main streets. Without the necessary safety improvements, additional traffic congestion would increase the number of safety hazards for our students. The safety of our students is our highest priority.

Impacts from the proposed development may also result in the need for additional classroom(s). The District's current Developer Fee Rates fall under Level I at \$5.17 per square foot for residential and \$0.84 per square foot for commercial developments. Developer

Page 2

fees are assessed annually and are therefore subject to change based on factors that impact growth within the District.

Should you need further information or have any questions, please contact me at (559) 274-4700 ext. 12102 or Kloya@centralunified.org

Katrina Loya
Central Unified School District
Facilities Planning Manager

October 21, 2024

City of Fresno
Planning Division
2600 Fresno Street
Fresno, CA 93721

Re: Tract 6397 - Pine Villas
1732 N Cornelia Avenue, Fresno, CA 93722

Dear City of Fresno,

Thank you for giving us the opportunity to review the Tract 6397 - Pine Villas Tentative Map. PG&E operates gas and electric facilities currently serving the existing residence on the subject property. The applicant must contact PG&E's Service Planning department at www.pge.com/cco for any modification or relocation requests, or for any additional services they may require prior to any proposed demolition or new construction.

The installation of new gas and electric facilities and/or relocation of existing PG&E facilities will be performed in accordance with common law or Rules and Tariffs as authorized by the California Public Utilities Commission. Following our review, PG&E recommends the following language be expressly stated for the offer to dedicate Public Utility Easements (PUE):

I/We the undersigned, as Owner(s) of the land shown hereon, do hereby state that I/we am/are the only person(s) whose consent is necessary to pass clear title to said land and do hereby consent to the preparation and recordation of this map and offer for dedication and do hereby dedicate for public uses the Public Utility Easements (PUEs) shown on this map for public utility purposes including electric, gas, communication facilities and all other public utility purposes; together with any and all appurtenances thereto, including the right from time to time to trim and to cut down and clear away or otherwise control any trees or brush. The PUEs hereby offered for dedication are to be kept open and free of buildings, structures and wells of any kind.

The final map must contain a statement setting forth dedications and offers to dedicate interests in real property for public utility purposes. If the offer of dedication has terminated, or the local agency declines to accept it, the applicant maybe required to provide an easement in gross satisfactory to PG&E. Please note that this is our preliminary review and PG&E reserves the right for future review as needed. Please work with PG&E's Service Planning department at www.pge.com/cco for additional services you may require, or for any modification and/or relocation requests.

Sincerely,

Alexa Boyd

Alexa Boyd - Land Management