

## **Exhibit O – Noise Assessment**

March 3, 2023

Mr. Moe Assad  
Mass Investment Group  
1788 E Niles  
Fresno, CA 93720

**Subject: SurfThru Car Wash McKinley and Fine – Noise Assessment – City of Fresno, CA**

Dear Mr. Assad:

MD Acoustics, LLC (MD) has completed a noise assessment for the proposed SurfThru Car Wash located at the north west corner of East McKinley avenue and North Fine Avenue, in Fresno CA. This assessment reviews the projected car wash operational noise levels and compares to the City's noise ordinance. The project proposes an approximately 2,003 square foot car wash tunnel with 16 vacuum bays.

### **1.0 Assessment Overview**

This assessment evaluates the projections operational noise and compares to the City's noise ordinance for informational purposes. The project location map is located in Exhibit A. The site plan utilized for the project is indicated in Exhibit BA glossary of Acoustical Terms is located in Appendix A.

### **2.0 Acoustical Requirements**

The City of Fresno outlines their noise regulations and standards within the Code of Ordinances from the Municipal Code. Article 1, Section 10-102 outlines the noise standards. As outlined in Section 10-102, residential noise levels may not exceed 60 dBA during daytime hours (7AM-7PM), 55 during evening hours (7PM-10PM). Additionally, commercial noise levels may not exceed 65 dBA during the daytime (7AM-7PM).

Therefore, the project may not exceed the strictest residential noise level during operational hours of 55 dBA and the commercial noise level of 65 dBA. at the corresponding adjacent properties.

### **3.0 Study Method and Procedure**

#### ***SoundPLAN Acoustic Model***

SoundPLAN (SP) acoustical modeling software was utilized to model future worst-case stationary noise impacts to the adjacent land uses. SP is capable of evaluating multiple stationary noise source impacts at various receiver locations.

Exhibit A  
Location Map

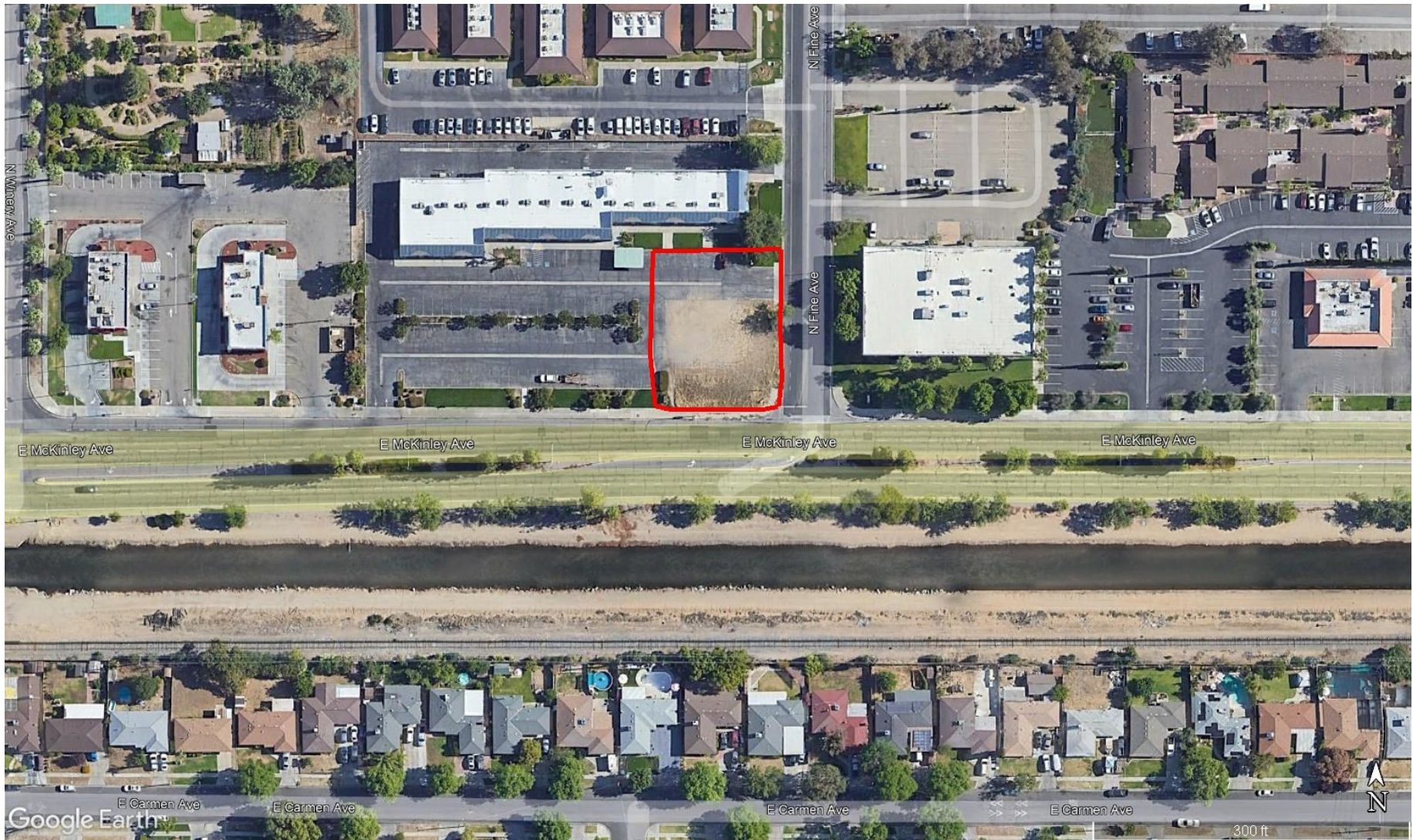



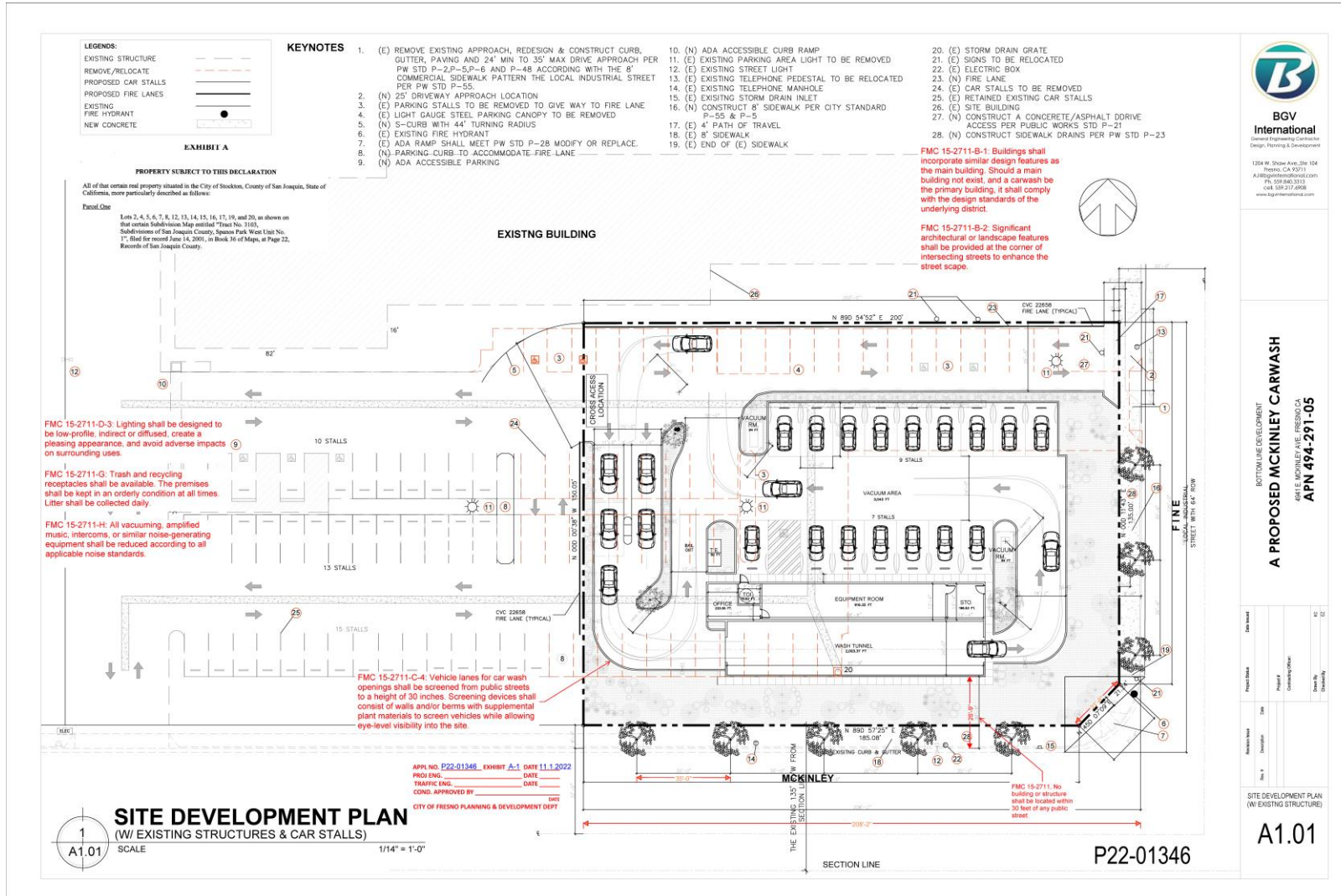

**BOTTOM LINE DEVELOPMENT**  
**A PROPOSED MCKINLEY CARWASH**  
 MCKINLEY & FINE, FRESNO, CA  
**APN 494-291-05**

Project Name	Client	Date	Scale
A1.01			

**SITE DEVELOPMENT PLAN**  
 (W/ EXISTING STRUCTURE)  
**A1.01**

SP's software utilizes algorithms (based on the inverse square law and reference equipment noise level data) to calculate noise level projections. The software allows the user to input specific noise sources, spectral content, sound barriers, building placement, topography, and sensitive receptor locations.

The future worst-case noise level projections were modeled using referenced sound level data for the various stationary on-site sources (vacuums, vacuum turbine motors and car wash blowers at the exit). The SP model assumes a total of 16 vacuums and the dryer system are operating simultaneously (worst-case scenario), when the noise will in reality be intermittent and lower in noise level.

In addition, the modeling takes into account existing property line walls, commercial buildings, and equipment enclosures proposed for the vacuum turbine. The reference vacuum equipment sound level data is provided in Appendix B.

All other noise producing equipment (e.g., compressors, pumps) will be housed within mechanical equipment rooms.

The following outlines the project design features:

1. The project will incorporate a IDC 120HP Stealth Predator Blower system within the tunnel.
2. The project proposes to house the vacuum turbine motors inside the attached fully enclosed equipment room.

SoundPlan input and output values are provided in Appendix C.

#### **4.0 Noise Level Projections and Recommendations**

The worst-case stationary noise was modeled using SoundPLAN acoustical modeling software. Worst-case assumes the blowers, vacuums and equipment are always operational when in reality the noise will be intermittent and cycle on/off depending on the customer usage.

The modeling takes into account the proposed tunnel and equipment design, enclosure for the vacuum turbines. Project operations are anticipated to occur within the City's allowable daytime standards.

A total of three (3) receptors (R1 – R3) were modeled to evaluate the proposed project's operational impact. R1 – R2 represents the noise level to the nearest commercial uses. R3 represents the nearest residential uses south of the project site across E McKinley Ave.

All yellow dots represent either a property line or a sensitive receptor such as an outdoor sensitive area (e.g. courtyard, patio, backyard, etc).

Exhibit C illustrates the noise level projections associated with the car wash noise operations when all equipment is fully active (even though the noise will be intermittent). The noise projections demonstrate that the operational noise level during operational hours to the nearest commercial uses will range between 60 to 61 dBA and will not exceed the City's 65 dBA commercial noise limit. The noise level at the

residences to the south are anticipated to measure 53 dBA which does not exceed the residential evening noise standard of 55 dBA.

## **5.0 Conclusions**

MD is pleased to provide this noise assessment for the SurfThru Car Wash project. Project operations are anticipated to comply with the City's noise ordinance. If you have any questions regarding this analysis, please call our office at (805) 426-4477.

Sincerely,  
MD Acoustics, LLC



Robert Pearson  
Acoustical Consultant

**Exhibit C**  
**Operational Noise Levels**

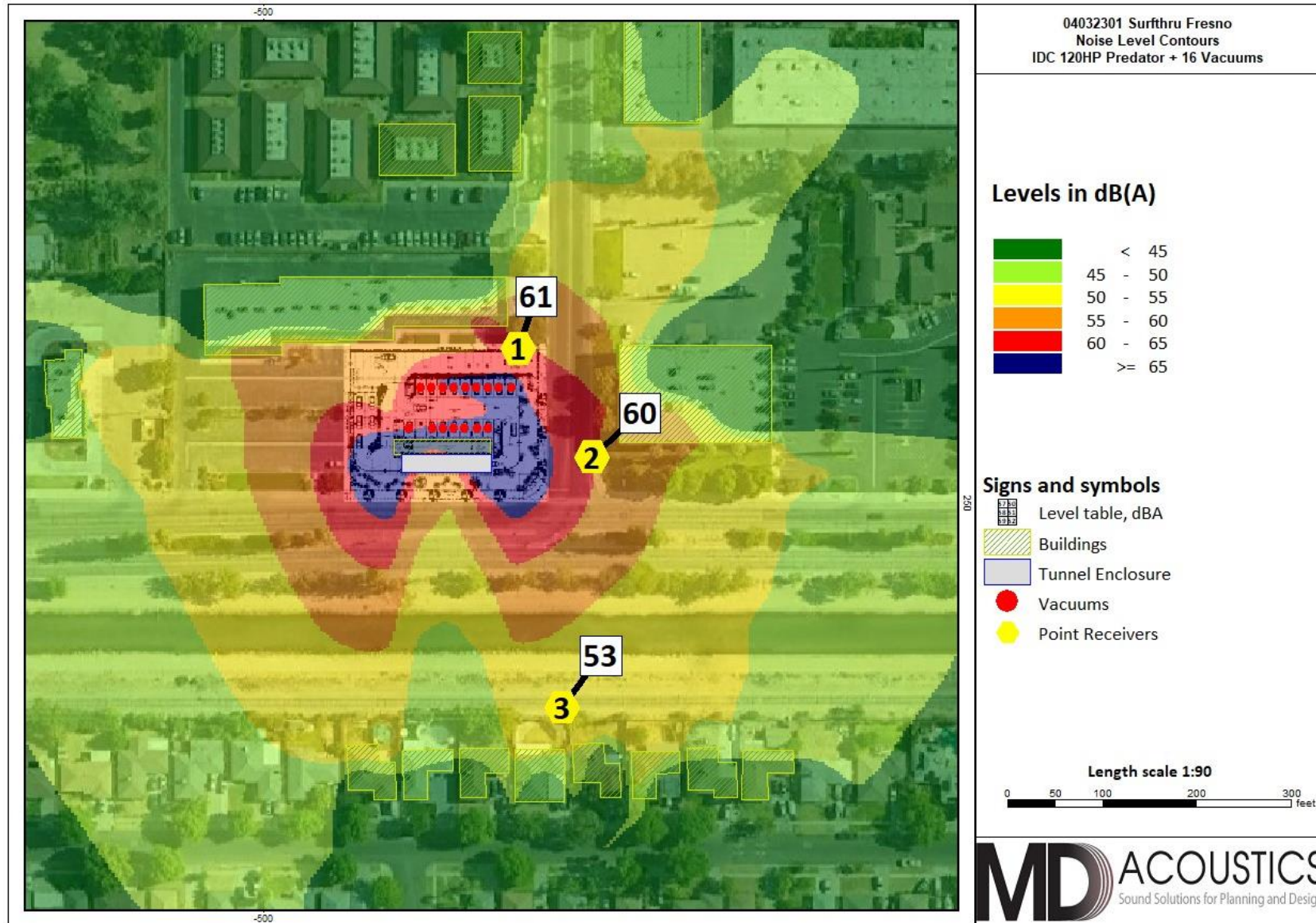

**Appendix A**  
Glossary of Acoustical Terms



## **Glossary of Terms**

**A-Weighted Sound Level:** The sound pressure level in decibels as measured on a sound level meter using the A-weighted filter network. The A-weighting filter de-emphasizes the very low and very high frequency components of the sound in a manner similar to the response of the human ear. A numerical method of rating human judgment of loudness.

**Ambient Noise Level:** The composite of noise from all sources, near and far. In this context, the ambient noise level constitutes the normal or existing level of environmental noise at a given location.

**Community Noise Equivalent Level (CNEL):** The average equivalent A-weighted sound level during a 24-hour day, obtained after addition of five (5) decibels to sound levels in the evening from 7:00 to 10:00 PM and after addition of ten (10) decibels to sound levels in the night before 7:00 AM and after 10:00 PM.

**Day-Night-Level (DNL or LDN):** The average equivalent A-weighted sound level during a 24-hour day, obtained after addition of ten (10) decibels to sound levels in the night before 7:00 AM and after 10:00 PM.

**Decibel (dB):** A unit for measuring the amplitude of a sound, equal to 20 times the logarithm to the base 10 of the ratio of the pressure of the sound measured to the reference pressure, which is 20 micro-pascals.

**dB(A):** A-weighted sound level (see definition above).

**Equivalent Sound Level (LEQ):** The sound level corresponding to a steady noise level over a given sample period with the same amount of acoustic energy as the actual time varying noise level. The energy average noise level during the sample period.

**Habitable Room:** Any room meeting the requirements of the Uniform Building Code or other applicable regulations which is intended to be used for sleeping, living, cooking or dining purposes, excluding such enclosed spaces as closets, pantries, bath or toilet rooms, service rooms, connecting corridors, laundries, unfinished attics, foyers, storage spaces, cellars, utility rooms and similar spaces.

**L(n):** The A-weighted sound level exceeded during a certain percentage of the sample time. For example, L10 in the sound level exceeded 10 percent of the sample time. Similarly L50, L90 and L99, etc.

**Noise:** Any unwanted sound or sound which is undesirable because it interferes with speech and hearing, or is intense enough to damage hearing, or is otherwise annoying. The State Noise Control Act defines noise as "...excessive undesirable sound...".

**Noise Criteria (NC) Method:** This metric plots octave band sound levels against a family of reference curves, with the number rating equal to the highest tangent line value as demonstrated in Figure 1.

**Percent Noise Levels:** See L(n).

**Room Criterion (RC) Method:** When sound quality in the space is important, the RC metric provides a diagnostic tool to quantify both the speech interference level and spectral imbalance.

**Sound Level (Noise Level):** The weighted sound pressure level obtained by use of a sound level meter having a standard frequency-filter for attenuating part of the sound spectrum.

**Sound Level Meter:** An instrument, including a microphone, an amplifier, an output meter, and frequency weighting networks for the measurement and determination of noise and sound levels.

**Sound Transmission Class (STC):** To quantify STC, a Transmission Loss (TL) measurement is performed in a laboratory over a range of 16 third-octave bands between 125 – 4,000 Hertz (Hz). The average human voice creates sound within the 125 – 4,000 Hz  $1/3^{\text{rd}}$  octave bands.

STC is a single-number rating given to a particular material or assembly. The STC rating measures the ability of a material or an assembly to resist airborne sound transfer over the specified frequencies (see ASTM International Classification E413 and E90). In general, a higher STC rating corresponds with a greater reduction of noise transmitting through a partition.

STC is highly dependent on the construction of the partition. The STC of a partition can be increased by: adding mass, increasing or adding air space, adding absorptive materials within the assembly. The STC rating does not assess low frequency sound transfer (e.g. sounds less than 125 Hz). Special consideration must be given to spaces where the noise transfer concern has lower frequencies than speech, such as mechanical equipment and or/or music. The STC rating is a lab test that does not take into consideration weak points, penetrations, or flanking paths.

Even with a high STC rating, any penetration, air-gap, or “flanking path can seriously degrade the isolation quality of a wall. Flanking paths are the means for sound to transfer from one space to

**FIGURE 1: Sample NC Curves and Sample Spectrum Levels**

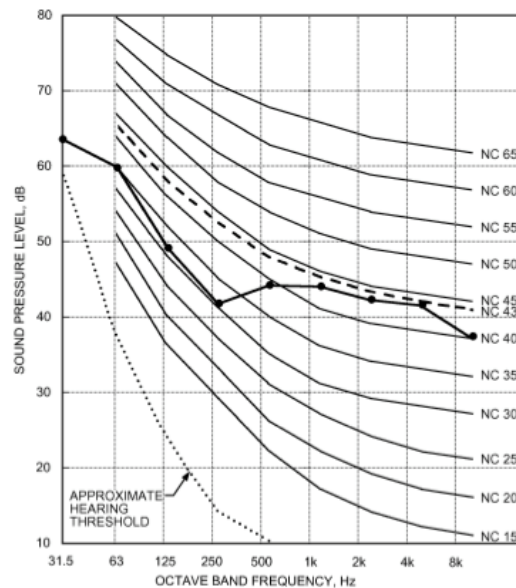

another other than through the wall. Sound can flank over, under, or around a wall. Sound can also travel through common ductwork, plumbing or corridors. Noise will travel between spaces at the weakest points. Typically, there is no reason to spend money or effort to improve the walls until all weak points are controlled first.

**Outdoor Living Area:** Outdoor spaces that are associated with residential land uses typically used for passive recreational activities or other noise-sensitive uses. Such spaces include patio areas, barbecue areas, jacuzzi areas, etc. associated with residential uses; outdoor patient recovery or resting areas associated with hospitals, convalescent hospitals, or rest homes; outdoor areas associated with places of worship which have a significant role in services or other noise-sensitive activities; and outdoor school facilities routinely used for educational purposes which may be adversely impacted by noise. Outdoor areas usually not included in this definition are: front yard areas, driveways, greenbelts, maintenance areas and storage areas associated with residential land uses; exterior areas at hospitals that are not used for patient activities; outdoor areas associated with places of worship and principally used for short-term social gatherings; and, outdoor areas associated with school facilities that are not typically associated with educational uses prone to adverse noise impacts (for example, school play yard areas).

**Percent Noise Levels:** See L(n).

**Sound Level (Noise Level):** The weighted sound pressure level obtained by use of a sound level meter having a standard frequency-filter for attenuating part of the sound spectrum.

**Sound Level Meter:** An instrument, including a microphone, an amplifier, an output meter, and frequency weighting networks for the measurement and determination of noise and sound levels.

**Single Event Noise Exposure Level (SENEL):** The dB(A) level which, if it lasted for one second, would produce the same A-weighted sound energy as the actual event.

**Appendix B**  
Referenced Equipment Noise Levels



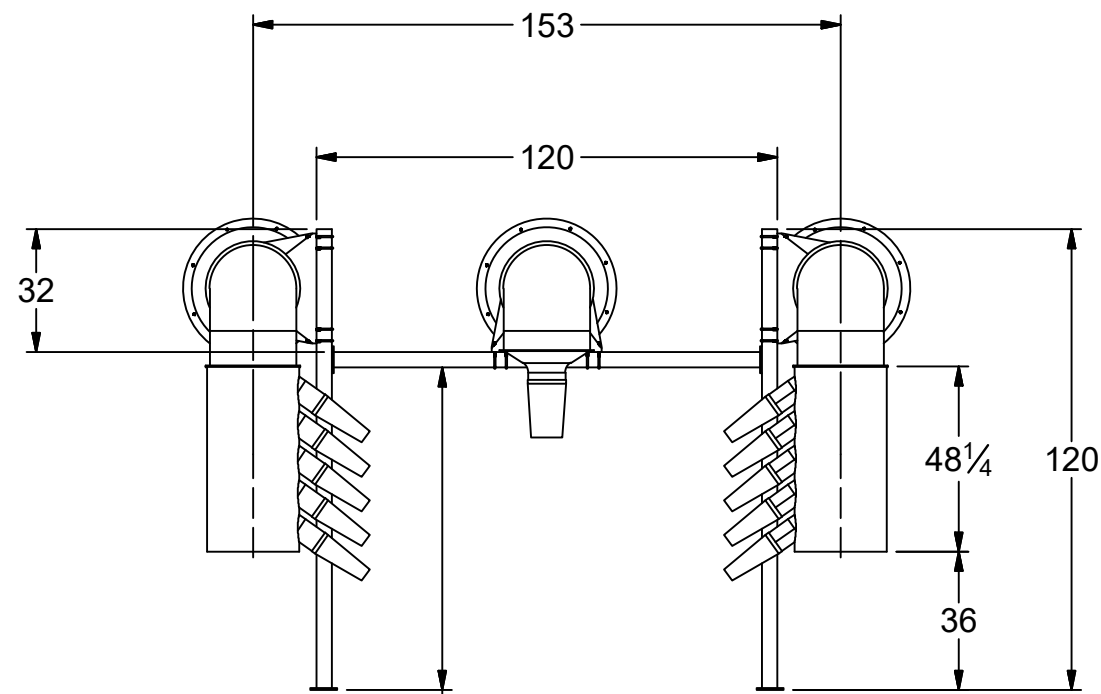
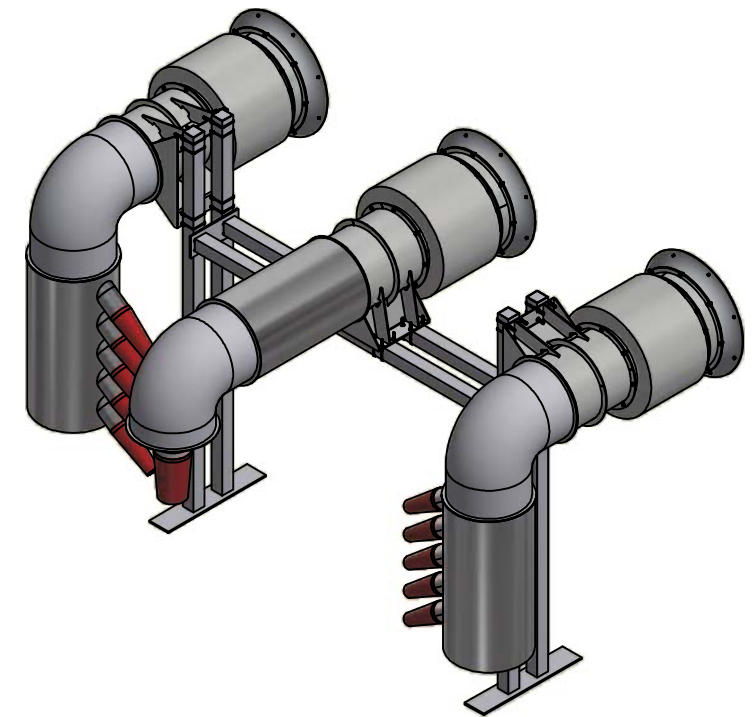
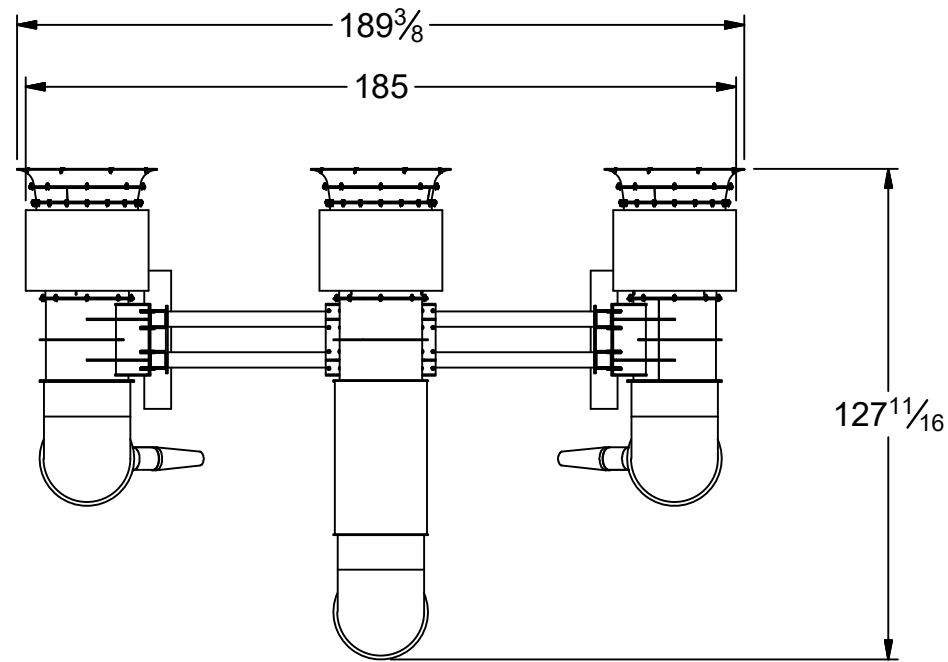

THIS HEIGHT IS ADJUSTABLE FROM 84"-120"

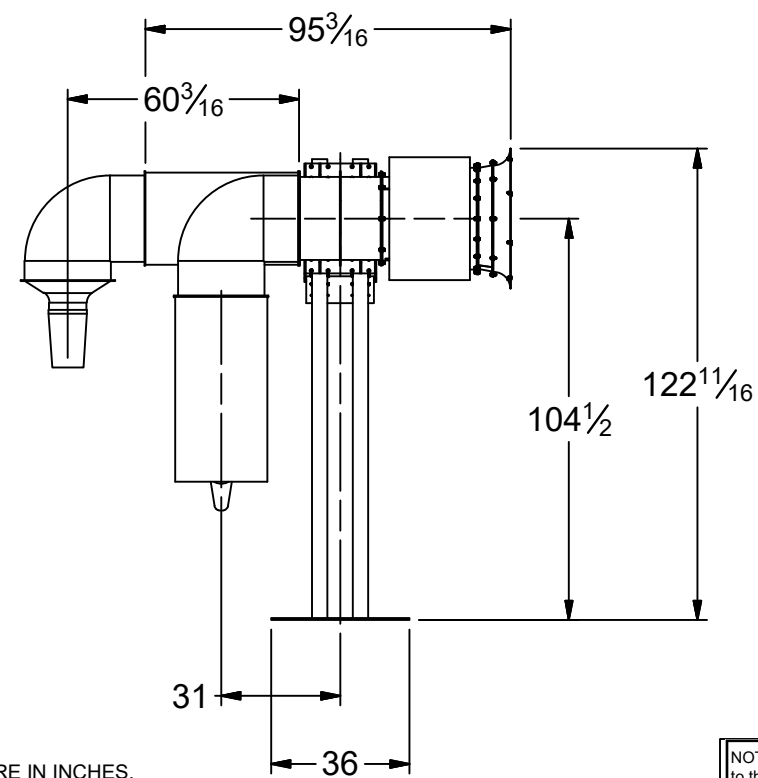

**GENERAL NOTES:**

1. UNLESS OTHERWISE SPECIFIED ALL DIMENSIONS ARE IN INCHES.
2. ALL FORMS ARE UP, UNLESS OTHERWISE SPECIFIED.
3. DIMENSIONS IN ( ) ARE FOR REFERENCE ONLY.

NOTICE: This drawing is property of International Drying Corporation and is loaned subject to the condition that it shall not be reproduced, copied, loaned or submitted to outside parties without our consent.

**DESCRIPTION:**

**PROJECT:**

FILE NUMBER: \_\_\_\_\_  
 SEQUENCE: \_\_\_\_\_  
 DRAWN BY: bogucki  
 DRAWN DATE: 1/31/2018  
 ENGINEER: \_\_\_\_\_  
 SCALE: \_\_\_\_\_

International Drying Corporation  
 2510 IL Route 176, Suite G  
 Prairie Grove, IL 60014  
 Phone (800) 736-6412  
 Art@InternationalDrying.com

**PART NUMBER**  
 WSP II-10  
**WITH ARCHES**

DWG. SIZE	MAT'L:	REV.
B	TOL: ± MASS: 2875.7 lbmass	A

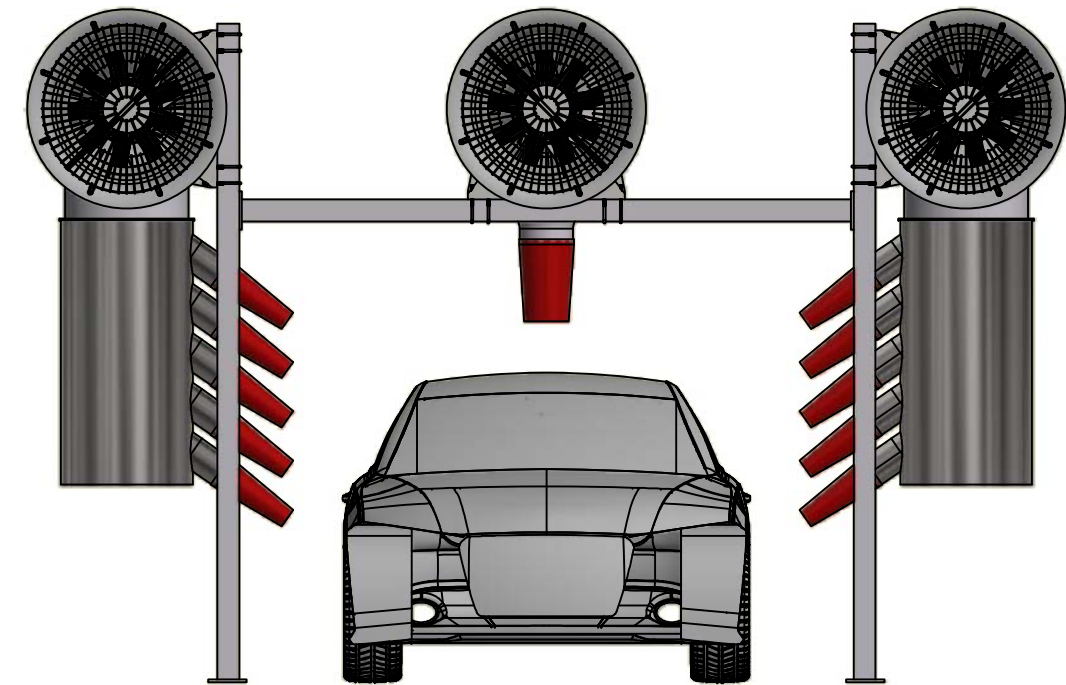
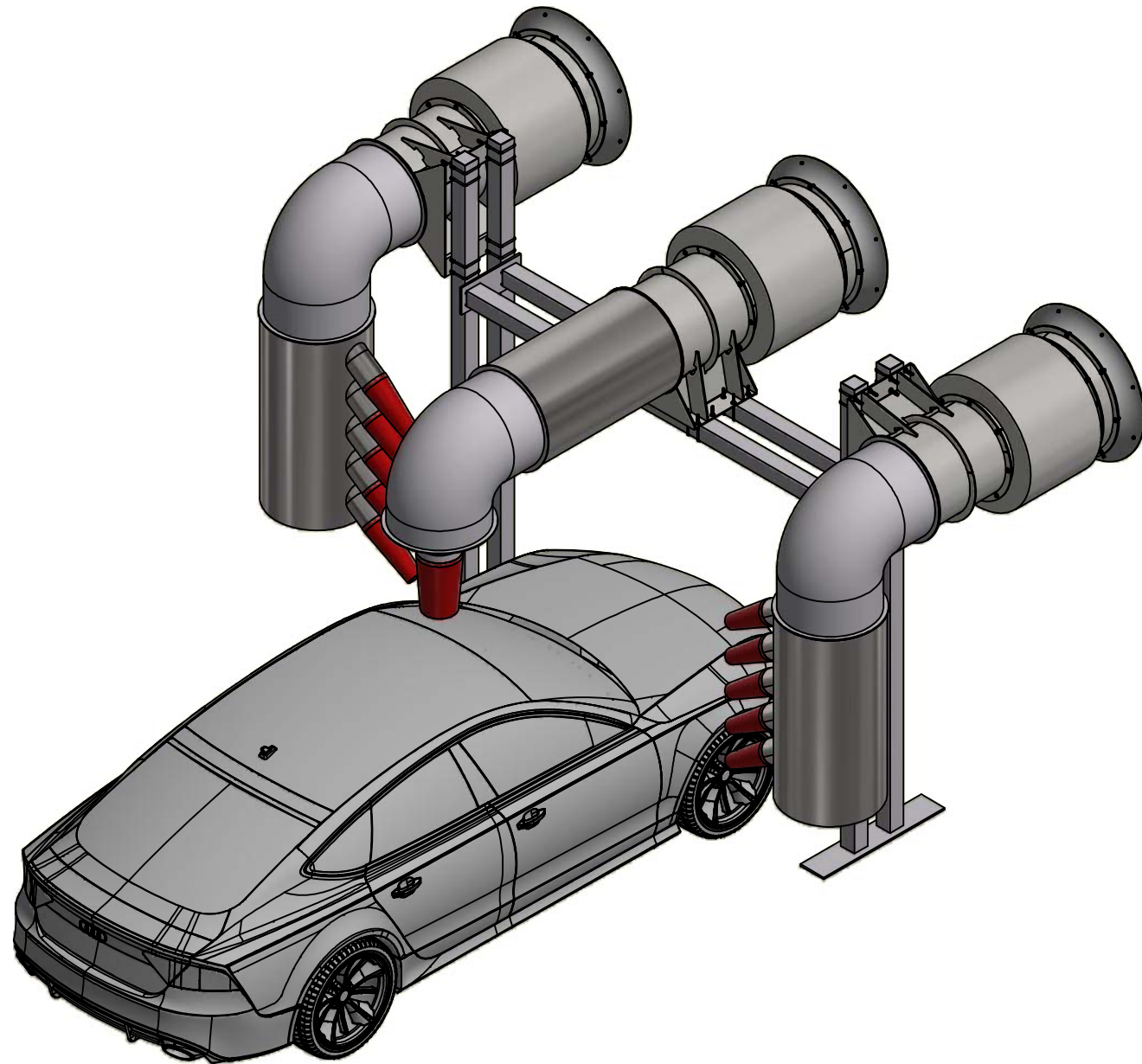

**GENERAL NOTES:**

1. UNLESS OTHERWISE SPECIFIED ALL DIMENSIONS ARE IN INCHES.
2. ALL FORMS ARE UP, UNLESS OTHER WISE SPECIFIED.
3. DIMENSIONS IN ( ) ARE FOR REFERENCE ONLY.

NOTICE: This drawing is property of International Drying Corporation and is loaned subject to the condition that it shall not be reproduced, copied, loaned or submitted to outside parties without our consent.

**DESCRIPTION:**

**PROJECT:**

FILE NUMBER: \_\_\_\_\_  
 SEQUENCE: \_\_\_\_\_  
 DRAWN BY: bogucki  
 DRAWN DATE: 1/31/2018  
 ENGINEER: \_\_\_\_\_  
 SCALE: \_\_\_\_\_

International Drying Corporation 2510 IL Route 176, Suite G Prairie Grove, IL 60014 Phone (800) 736-6412 Art@InternationalDrying.com		<b>PART NUMBER</b> WSP II-10 <b>WITH ARCHES</b>
DWG. SIZE B	MAT'L: _____ TOL: ± _____ MASS: 2875.7 lbmass	REV. A



**Stealth High Powered Quiet Drying System Specifications**

Center Band Sound Frequency	63 Hz	125Hz	250 Hz	500 Hz	1,000Hz	2,000 Hz	4,000 Hz	8,000 Hz	Total Sound 60 Hz Results	
Final Sound Pressure Level	55.3	60.4	71.9	80.3	78.5	76.7	72.5	65.4	84.2	dBA at Q=1, 5 feet
Final Sound Pressure Level	49.3	54.4	65.9	74.3	72.5	70.7	66.5	59.4	78.2	dBA at Q=1, 10 feet
Final Sound Pressure Level	45.8	50.9	62.4	70.8	69	67.2	63	55.9	74.7	dBA at Q=1, 15 feet
Final Sound Pressure Level	43.3	48.4	59.9	68.3	66.5	64.7	60.5	53.4	72.2	dBA at Q=1, 20 feet
Final Sound Pressure Level	41.3	46.4	57.9	66.3	64.5	62.7	58.5	51.4	70.2	dBA at Q=1, 25 feet
Final Sound Pressure Level	39.8	44.9	56.4	64.8	63	61.2	57	49.9	68.7	dBA at Q=1, 30 feet
Final Sound Pressure Level	38.4	43.5	55	63.4	61.6	59.8	55.6	48.5	67.3	dBA at Q=1, 35 feet
Final Sound Pressure Level	37.3	42.4	53.9	62.3	60.5	58.7	54.5	47.4	66.2	dBA at Q=1, 40 feet
Final Sound Pressure Level	36.2	41.3	52.8	61.2	59.4	57.6	53.4	46.3	65.1	dBA at Q=1, 45 feet
Final Sound Pressure Level	35.3	40.4	51.9	60.3	58.5	56.7	52.5	45.4	64.2	dBA at Q=1, 50 feet
Final Sound Pressure Level	34.5	39.6	51.1	59.5	57.7	55.9	51.7	44.6	63.4	dBA at Q=1, 55 feet

Sound pressure values are approximated from AMCA 300 Reverberant sound room total sound power values

\* all information provided through **the new york blower company** via tests performed in their La Port IN sound lab, January 15th 2018



### SOUND LEVEL METER READINGS

**MODEL:** FT-DD-T340HP4 (40hp VACSTAR TURBINE VACUUM PRODUCER)

**READING ONE:** 43 DB-A, 3 FEET FROM TURBINE @ 45° ANGLE  
AND NO BACKGROUND NOISE OR OUTSIDE INTERFERENCE.

**READING TWO:** 36 DB-A, 10 FEET FROM TURBINE @ 45° ANGLE  
AND NO BACKGROUND NOISE OR OUTSIDE INTERFERENCE.

**READING THREE:** 24 DB-A, 20 FEET FROM TURBINE @ 45° ANGLE  
AND NO BACKGROUND NOISE OR OUTSIDE INTERFERENCE.

**READING FOUR:** 12 DB-A, 30 FEET FROM TURBINE @ 45° ANGLE  
AND NO BACKGROUND NOISE OR OUTSIDE INTERFERENCE.

**NOTE:** THESE READINGS WERE TAKEN OUTSIDE OF 8'x10'x8' CINDER BLOCK ENCLOSURE WITH CONCRETE SLAB AND WOOD JOIST ROOF.

### SOUND LEVEL METER USED:

SIMPSON MODEL #40003 – MSHA APPROVED.  
MEETS OSHA & WALSH-HEALY REQUIREMENTS FOR NOISE CONTROL.  
CONFORMS TO ANSI S1.4-1983, IEC 651 SPECS FOR METER TYPE.

*Vacutech*  
**1350 Hi-Tech Drive, Sheridan WY, 82801**  
**PHONE: (800) 917-9444 FAX: (303) 675-1988**  
**EMAIL: [info@vacutechllc](mailto:info@vacutechllc)**  
**WEB SITE: [vacutechllc.com](http://vacutechllc.com)**



**Project:** Sound Library  
**Job Number:** 0000-2020-02  
**Site Address/Location:** 1555 W Warner Rd, Gilbert, AZ 85233  
**Date:** 04/05/2020  
**Field Tech/Engineer:** Robert Pearson  
**Source/System:** Vacutec System Averaged

**Site Observations:**

Clear sky, measurements were performed within 1.5ft of source. Measurements were performed while the vacuum was positioned at three (3) different positions. Holstered, upholstered and inside a car. This data is utilized for acoustic modeling purposes and represents an average sound level at a vacuum station.

**General Location:** Measured @ 1.5'  
**Sound Meter:** NtI XL2 **SN:** A2A-05967-E0  
**Settings:** A-weighted, slow, 1-sec, 10-sec duration  
**Meteorological Cond.:** 80 degrees, 2 mph wind

Leq	Lmin	Lmax
71.2	71.2	71.2

Ln 2	Ln 8	Ln 25	Ln 50	Ln 90	Ln 99
0.0	0.0	0.0	0.0	0.0	0.0

**Table 1: Summary Measurement Data**

Source/System	Overall Source	Overall dB(A)	3rd Octave Band Data (dBA)																														
			20	25	31.5	40	50	63	80	100	125	160	200	250	315	400	500	630	800	1k	12.5k	1.6k	2k	2.5k	3.15k	4k	5k	6.3k	8k	10k	12.5k	16k	20k
Vacutec System Averaged	Car Wash Vacuu	71.2	11.0	21.0	25.0	32.0	36.0	39.0	43.0	45.0	47.0	48.0	52.0	53.0	51.0	51.0	55.0	53.0	55.0	55.0	56.0	58.0	59.0	59.0	61.0	62.0	59.0	56.0	55.0	53.0	51.0	47.0	40.0

**Figure 1: Vacutec System Averaged**

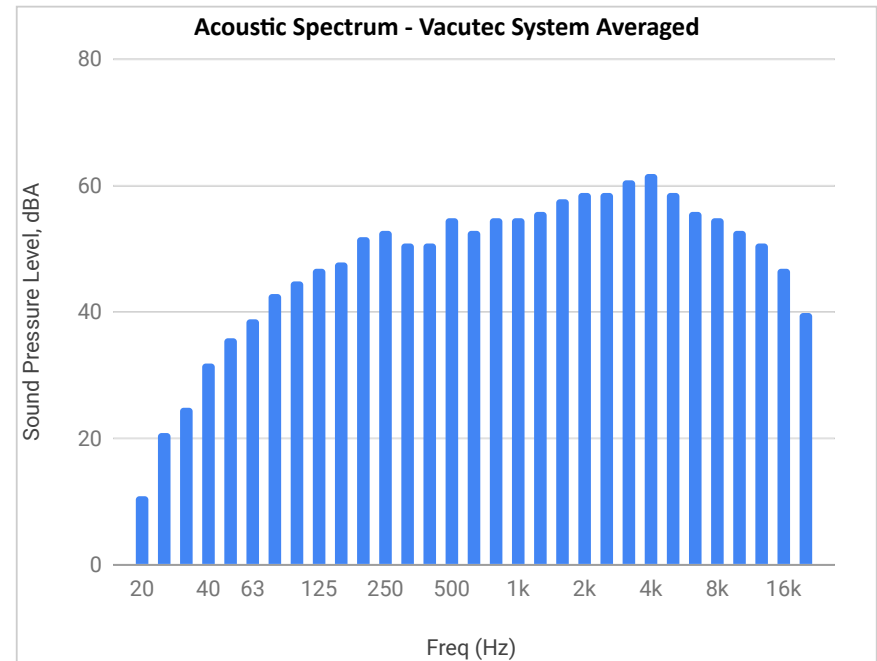

**Project:** SuperStar Car Wash Chula Vista  
**Site Location:** 1555 W Warner Rd, Gilbert, AZ 85233  
**Date:** 4/5/2018  
**Field Tech/Engineer:** Robert Pearson  
**Source/System:** Vacutec System

**Site Observations:** Clear sky, measurements were performed within 1.5ft of source. Measurements were performed while the vacuum was positioned at threee (3) different positions. Holstered, unholstered and inside a car. This data is utilized for acoustic modeling purposes and represents an average sound level at a vacuum station.

**Location:** Vac Bay 1  
**Sound Meter:** NTi XL2 **SN:** A2A-05967-E0  
**Settings:** A-weighted, slow, 1-sec, 10-sec duration  
**Meteorological Cond.:** 80 degrees F, 2 mph wind

**Table 1: Summary Measurement Data**

Source	System	Overall dB(A)	3rd Octave Band Data (dBA)																														
			20	25	31.5	40	50	63	80	100	125	160	200	250	315	400	500	630	800	1K	1.25K	1.6K	2K	2.5K	3.15K	4K	5K	6.3K	8K	10K	12.5K	16K	20K
Vacutec (Holstered)	Vacuum	63.3	9	17	22	29	31	35	40	41	44	43	46	48	47	49	51	51	52	53	52	52	50	52	53	50	47	47	48	45	39	30	
Vacutec (Un Holstered)	Vacuum	80.7	6	19	22	28	34	37	40	43	47	46	48	48	49	54	55	58	58	62	65	68	70	74	75	73	69	67	65	63	60	55	
Vacutec (Inside Car)	Vacuum	69.6	16	28	31	38	42	45	49	51	52	55	60	61	57	55	59	53	55	56	54	57	57	57	57	55	54	51	48	46	42	36	
<b>Arth. Average Level*</b>	<b>Vacuum</b>	<b>71.2</b>	<b>11</b>	<b>21</b>	<b>25</b>	<b>32</b>	<b>36</b>	<b>39</b>	<b>43</b>	<b>45</b>	<b>47</b>	<b>48</b>	<b>52</b>	<b>53</b>	<b>51</b>	<b>51</b>	<b>55</b>	<b>53</b>	<b>55</b>	<b>55</b>	<b>56</b>	<b>58</b>	<b>59</b>	<b>59</b>	<b>61</b>	<b>62</b>	<b>59</b>	<b>56</b>	<b>55</b>	<b>53</b>	<b>51</b>	<b>47</b>	<b>40</b>

\* Refers to the arithmetic average of all measurements. This measurement represents an average of the multiple vacuum positions.

**Figure 1: Example Measurement Position**

**Figure 1: Holstered**



**Figure 2: Un Holstered**



**Figure 3: Inside Car**

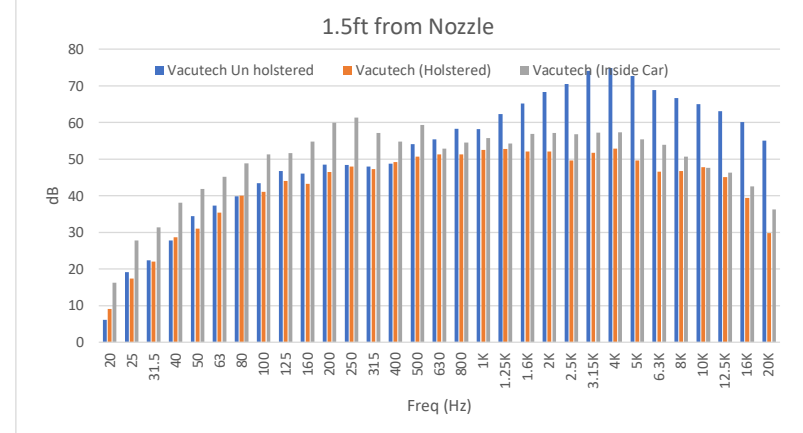
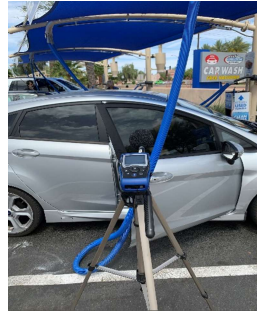

**Appendix C**  
SoundPlan Input/Output

## SurfThru Fresno

### 3rd octave spectra of the sources in dB(A) - Situation 1 - IDC 120HP Pred - SP

Name	I or A m,m²	Li dB(A)	R'w dB	L'w dB(A)	Lw dB(A)	25Hz dB(A)	31.5Hz dB(A)	40Hz dB(A)	50Hz dB(A)	63Hz dB(A)	80Hz dB(A)	100Hz dB(A)	125Hz dB(A)	160Hz dB(A)	200Hz dB(A)	250Hz dB(A)	315Hz dB(A)	400Hz dB(A)	500Hz dB(A)	630Hz dB(A)	800Hz dB(A)	1kHz dB(A)	1.25kHz dB(A)	1.6kHz dB(A)	2kHz dB(A)	2.5kHz dB(A)	3.15kHz dB(A)	4kHz dB(A)	5kHz dB(A)	6.3kHz dB(A)	8kHz dB(A)	10kHz dB(A)
Vacuum 1				80.6	80.6	28.1	31.7	38.4	42	45.6	49.2	51.7	52.8	55.0	59.9	61.2	57.5	56.1	60.3	57.7	59.8	60.3	62.7	65.4	68.1	70.1	73.6	74.4	72.2	68.4	66.2	64.6
Vacuum 2				80.6	80.6	28.1	31.7	38.4	42	45.6	49.2	51.7	52.8	55.0	59.9	61.2	57.5	56.1	60.3	57.7	59.8	60.3	62.7	65.4	68.1	70.1	73.6	74.4	72.2	68.4	66.2	64.6
Vacuum 3				80.6	80.6	28.1	31.7	38.4	42	45.6	49.2	51.7	52.8	55.0	59.9	61.2	57.5	56.1	60.3	57.7	59.8	60.3	62.7	65.4	68.1	70.1	73.6	74.4	72.2	68.4	66.2	64.6
Vacuum 4				80.6	80.6	28.1	31.7	38.4	42	45.6	49.2	51.7	52.8	55.0	59.9	61.2	57.5	56.1	60.3	57.7	59.8	60.3	62.7	65.4	68.1	70.1	73.6	74.4	72.2	68.4	66.2	64.6
Vacuum 5				80.6	80.6	28.1	31.7	38.4	42	45.6	49.2	51.7	52.8	55.0	59.9	61.2	57.5	56.1	60.3	57.7	59.8	60.3	62.7	65.4	68.1	70.1	73.6	74.4	72.2	68.4	66.2	64.6
Vacuum 6				80.6	80.6	28.1	31.7	38.4	42	45.6	49.2	51.7	52.8	55.0	59.9	61.2	57.5	56.1	60.3	57.7	59.8	60.3	62.7	65.4	68.1	70.1	73.6	74.4	72.2	68.4	66.2	64.6
Vacuum 7				80.6	80.6	28.1	31.7	38.4	42	45.6	49.2	51.7	52.8	55.0	59.9	61.2	57.5	56.1	60.3	57.7	59.8	60.3	62.7	65.4	68.1	70.1	73.6	74.4	72.2	68.4	66.2	64.6
Vacuum 8				80.6	80.6	28.1	31.7	38.4	42	45.6	49.2	51.7	52.8	55.0	59.9	61.2	57.5	56.1	60.3	57.7	59.8	60.3	62.7	65.4	68.1	70.1	73.6	74.4	72.2	68.4	66.2	64.6
Vacuum 9				80.6	80.6	28.1	31.7	38.4	42	45.6	49.2	51.7	52.8	55.0	59.9	61.2	57.5	56.1	60.3	57.7	59.8	60.3	62.7	65.4	68.1	70.1	73.6	74.4	72.2	68.4	66.2	64.6
Vacuum 10				80.6	80.6	28.1	31.7	38.4	42	45.6	49.2	51.7	52.8	55.0	59.9	61.2	57.5	56.1	60.3	57.7	59.8	60.3	62.7	65.4	68.1	70.1	73.6	74.4	72.2	68.4	66.2	64.6
Vacuum 11				80.6	80.6	28.1	31.7	38.4	42	45.6	49.2	51.7	52.8	55.0	59.9	61.2	57.5	56.1	60.3	57.7	59.8	60.3	62.7	65.4	68.1	70.1	73.6	74.4	72.2	68.4	66.2	64.6
Vacuum 12				80.6	80.6	28.1	31.7	38.4	42	45.6	49.2	51.7	52.8	55.0	59.9	61.2	57.5	56.1	60.3	57.7	59.8	60.3	62.7	65.4	68.1	70.1	73.6	74.4	72.2	68.4	66.2	64.6
Vacuum 13				80.6	80.6	28.1	31.7	38.4	42	45.6	49.2	51.7	52.8	55.0	59.9	61.2	57.5	56.1	60.3	57.7	59.8	60.3	62.7	65.4	68.1	70.1	73.6	74.4	72.2	68.4	66.2	64.6
Vacuum 14				80.6	80.6	28.1	31.7	38.4	42	45.6	49.2	51.7	52.8	55.0	59.9	61.2	57.5	56.1	60.3	57.7	59.8	60.3	62.7	65.4	68.1	70.1	73.6	74.4	72.2	68.4	66.2	64.6
Vacuum 15				80.6	80.6	28.1	31.7	38.4	42	45.6	49.2	51.7	52.8	55.0	59.9	61.2	57.5	56.1	60.3	57.7	59.8	60.3	62.7	65.4	68.1	70.1	73.6	74.4	72.2	68.4	66.2	64.6
Vacuum 16				80.6	80.6	28.1	31.7	38.4	42	45.6	49.2	51.7	52.8	55.0	59.9	61.2	57.5	56.1	60.3	57.7	59.8	60.3	62.7	65.4	68.1	70.1	73.6	74.4	72.2	68.4	66.2	64.6
Roof 01	174.00	88.0	57.0	39.2	61.6					54.1			48.2		59.2			54.2			41.8			35.5			25.9			14.3		
Facade 01	101.50	88.4	57.0	39.6	59.6					52.1			46.2		57.3			52.2			39.8			33.6			23.9			12.1		
Facade 02	10.05	89.0	57.0	39.9	50.0					42.4			36.5		47.6			42.6			30.6			24.8			15.3			4.7		
Transmissive area 01	10.95	88.8	0.0	88.8	99.2					72.6			80.8		93.8			94.8			91.9			90.2			83.8			71.2		
Facade 03	101.50	88.4	57.0	39.6	59.6					52.1			46.2		57.3			52.2			39.8			33.6			23.9			12.1		
Facade 04	10.05	87.9	57.0	39.1	49.1					41.6			35.8		46.8			41.7			29.3			23.1			13.2			0.4		
Transmissive area 01	10.95	87.5	0.0	87.5	97.9					71.5			79.6		92.7			93.7			90.4			88.2			81.3			66.6		



**SurfThru Fresno**  
**Contribution level - Situation 1 - IDC 120HP Pred - SP**

**9**

Source	Source type	Leq,d dB(A)	A dB	
<b>Receiver 1</b>				
FIG	Lr,lim	dB(A) Leq,d 60.8 dB(A)		Sigma(Leq,d) 0.0 dB(A)
Vacuum 1	Point	41.8	0.0	
Vacuum 2	Point	42.3	0.0	
Vacuum 3	Point	43.0	0.0	
Vacuum 4	Point	43.9	0.0	
Vacuum 5	Point	45.0	0.0	
Vacuum 6	Point	45.7	0.0	
Vacuum 7	Point	46.1	0.0	
Vacuum 8	Point	47.2	0.0	
Vacuum 9	Point	48.1	0.0	
Vacuum 10	Point	40.7	0.0	
Vacuum 11	Point	41.6	0.0	
Vacuum 12	Point	42.1	0.0	
Vacuum 13	Point	42.2	0.0	
Vacuum 14	Point	41.7	0.0	
Vacuum 15	Point	42.3	0.0	
Vacuum 16	Point	41.2	0.0	
Roof 01	Area	8.4	0.0	
Facade 01	Area	7.1	0.0	
Facade 02	Area	9.8	0.0	
Transmissive area 01	Area	59.0	0.0	
Facade 03	Area	7.8	0.0	
Facade 04	Area	-4.8	0.0	
Transmissive area 01	Area	38.2	0.0	
<b>Receiver 2</b>				
FIG	Lr,lim	dB(A) Leq,d 60.4 dB(A)		Sigma(Leq,d) 0.0 dB(A)
Vacuum 1	Point	35.4	0.0	
Vacuum 2	Point	35.8	0.0	
Vacuum 3	Point	35.6	0.0	
Vacuum 4	Point	36.1	0.0	
Vacuum 5	Point	37.0	0.0	
Vacuum 6	Point	36.7	0.0	
Vacuum 7	Point	37.5	0.0	
Vacuum 8	Point	38.1	0.0	
Vacuum 9	Point	38.9	0.0	
Vacuum 10	Point	31.5	0.0	
Vacuum 11	Point	35.5	0.0	
Vacuum 12	Point	35.3	0.0	
Vacuum 13	Point	36.1	0.0	
Vacuum 14	Point	37.0	0.0	
Vacuum 15	Point	37.9	0.0	
Vacuum 16	Point	38.8	0.0	
Roof 01	Area	13.4	0.0	
Facade 01	Area	13.1	0.0	
Facade 02	Area	11.2	0.0	

**SurfThru Fresno**  
**Contribution level - Situation 1 - IDC 120HP Pred - SP**

**9**

Source	Source type	Leq,d dB(A)	A dB	
Transmissive area 01	Area	60.0	0.0	
Facade 03	Area	14.3	0.0	
Facade 04	Area	-3.3	0.0	
Transmissive area 01	Area	36.5	0.0	
Receiver 3 FIG Lr,lim dB(A) Leq,d 52.8 dB(A) Sigma(Leq,d) 0.0 dB(A)				
Vacuum 1	Point	21.0	0.0	
Vacuum 2	Point	21.0	0.0	
Vacuum 3	Point	22.4	0.0	
Vacuum 4	Point	25.4	0.0	
Vacuum 5	Point	26.6	0.0	
Vacuum 6	Point	29.6	0.0	
Vacuum 7	Point	30.2	0.0	
Vacuum 8	Point	29.4	0.0	
Vacuum 9	Point	29.2	0.0	
Vacuum 10	Point	16.0	0.0	
Vacuum 11	Point	21.4	0.0	
Vacuum 12	Point	25.1	0.0	
Vacuum 13	Point	26.1	0.0	
Vacuum 14	Point	25.8	0.0	
Vacuum 15	Point	25.9	0.0	
Vacuum 16	Point	31.5	0.0	
Roof 01	Area	11.1	0.0	
Facade 01	Area	12.1	0.0	
Facade 02	Area	2.9	0.0	
Transmissive area 01	Area	52.4	0.0	
Facade 03	Area	3.2	0.0	
Facade 04	Area	-3.4	0.0	
Transmissive area 01	Area	38.6	0.0	

## SurfThru Fresno

### Contribution spectra - Situation 1 - IDC 120HP Pred - SP

Source	Time slice	Sum dB(A)	63Hz dB(A)	125Hz dB(A)	250Hz dB(A)	500Hz dB(A)	1kHz dB(A)	2kHz dB(A)	4kHz dB(A)	8kHz dB(A)	16kHz dB(A)
Receiver 1 FI G Lr,lim dB(A) Leq,d 60.8 dB(A) Sigma(Leq,d) 0.0 dB(A)											
Facade 01	Leq,d	7.1	5.4	-5.7	0.5	-7.1	-15.0	-22.1			
Facade 02	Leq,d	9.8	5.8	-2.4	5.2	2.1	-7.7	-13.3	-23.7		
Facade 03	Leq,d	7.8	5.8	-4.7	1.7	-4.7	-16.2	-22.5			
Facade 04	Leq,d	-4.8	-6.5	-18.2	-11.0	-19.4					
Roof 01	Leq,d	8.4	5.6	-5.1	3.7	-2.2	-15.1	-20.4			
Transmissive area 01	Leq,d	59.0	36.0	41.9	51.0	53.7	53.4	52.1	44.7	28.6	
Transmissive area 01	Leq,d	38.2	23.0	25.4	34.0	31.5	27.0	32.0	20.5	-3.7	
Vacuum 1	Leq,d	41.8	12.0	18.0	22.3	21.1	27.6	35.5	39.8	29.5	14.3
Vacuum 2	Leq,d	42.3	12.9	18.8	23.2	21.8	28.0	35.9	40.3	30.4	15.9
Vacuum 3	Leq,d	43.0	13.9	19.8	24.4	22.8	28.7	36.5	41.0	31.5	17.7
Vacuum 4	Leq,d	43.9	14.9	20.8	25.5	23.9	29.6	37.3	41.9	32.6	19.4
Vacuum 5	Leq,d	45.0	16.1	22.4	27.0	25.3	30.6	38.4	43.0	34.0	21.6
Vacuum 6	Leq,d	45.7	17.3	23.5	28.1	26.3	31.3	38.9	43.7	35.0	23.3
Vacuum 7	Leq,d	46.1	18.6	24.1	28.9	27.0	31.6	39.2	44.0	35.7	24.9
Vacuum 8	Leq,d	47.2	19.6	25.2	30.2	28.3	32.7	40.2	45.1	37.0	26.5
Vacuum 9	Leq,d	48.1	20.4	26.0	31.2	29.3	33.5	41.0	46.0	37.9	27.7
Vacuum 10	Leq,d	40.7	9.8	17.9	21.0	19.5	26.6	34.7	38.7	27.7	10.6
Vacuum 11	Leq,d	41.5	11.1	19.0	22.4	20.7	27.4	35.4	39.6	29.1	13.2
Vacuum 12	Leq,d	42.1	12.4	19.5	23.0	21.4	27.9	35.8	40.1	29.8	14.3
Vacuum 13	Leq,d	42.2	12.9	19.9	23.3	21.6	28.0	35.8	40.2	30.2	15.3
Vacuum 14	Leq,d	41.7	13.5	20.1	23.1	21.4	27.4	35.3	39.7	30.1	15.8
Vacuum 15	Leq,d	42.3	14.1	20.7	23.9	22.2	28.0	35.8	40.3	30.8	17.0
Vacuum 16	Leq,d	41.2	13.9	19.3	22.8	21.2	26.8	34.6	39.2	29.9	16.7
Receiver 2 FI G Lr,lim dB(A) Leq,d 60.4 dB(A) Sigma(Leq,d) 0.0 dB(A)											
Facade 01	Leq,d	13.1	10.4	1.2	8.0	2.7	-8.0	-15.4	-28.1		
Facade 02	Leq,d	11.2	7.1	-1.1	6.9	3.1	-7.0	-12.6	-22.8		
Facade 03	Leq,d	14.3	11.0	2.2	9.6	5.1	-5.3	-11.4	-22.5		
Facade 04	Leq,d	-3.3	-4.8	-16.4	-10.3	-17.4					
Roof 01	Leq,d	13.4	8.5	-0.5	10.2	5.0	-6.6	-13.4	-25.1		
Transmissive area 01	Leq,d	60.0	37.4	43.2	52.7	54.7	54.2	52.9	45.7	30.4	
Transmissive area 01	Leq,d	36.5	23.1	24.7	31.9	30.6	26.6	29.2	17.2	-7.1	
Vacuum 1	Leq,d	35.3	7.1	12.3	13.6	13.6	21.5	29.7	33.3	21.1	1.1
Vacuum 2	Leq,d	35.8	7.6	12.8	14.3	14.1	21.9	30.1	33.8	21.8	2.4
Vacuum 3	Leq,d	35.5	8.1	13.4	15.0	14.2	21.5	29.7	33.6	22.2	3.7
Vacuum 4	Leq,d	36.1	8.6	13.9	15.8	14.9	22.0	30.1	34.1	22.9	5.1
Vacuum 5	Leq,d	37.0	9.3	14.6	16.7	15.7	22.7	31.1	35.0	24.0	6.8
Vacuum 6	Leq,d	36.6	9.9	15.2	17.4	15.6	22.3	30.5	34.7	24.2	8.0
Vacuum 7	Leq,d	37.5	10.5	15.9	18.3	16.5	23.1	31.3	35.5	25.1	9.5
Vacuum 8	Leq,d	38.0	11.1	16.5	19.2	17.3	23.7	31.7	36.0	26.0	10.9
Vacuum 9	Leq,d	38.8	11.9	17.3	20.2	18.4	24.4	32.4	36.8	27.1	12.6
Vacuum 10	Leq,d	31.4	4.3	8.9	11.0	10.2	18.2	26.1	29.3	16.0	-6.5
Vacuum 11	Leq,d	35.4	8.2	13.5	15.1	13.9	21.6	29.6	33.4	22.0	3.8
Vacuum 12	Leq,d	35.3	8.8	14.1	15.9	14.1	21.3	29.2	33.3	22.5	5.3
Vacuum 13	Leq,d	36.1	9.5	14.8	16.8	15.0	22.0	29.9	34.1	23.5	6.9
Vacuum 14	Leq,d	36.9	10.1	15.5	17.8	15.9	22.7	30.8	34.9	24.5	8.6
Vacuum 15	Leq,d	37.9	11.0	16.4	19.0	17.2	23.6	31.6	35.9	25.8	10.6
Vacuum 16	Leq,d	38.8	11.8	17.2	20.1	18.2	24.5	32.5	36.8	27.0	12.4
Receiver 3 FI G Lr,lim dB(A) Leq,d 52.8 dB(A) Sigma(Leq,d) 0.0 dB(A)											
Facade 01	Leq,d	12.1	8.6	0.1	7.0	4.3	-4.6	-10.9	-22.7		
Facade 02	Leq,d	2.9	-0.7	-9.5	-2.1	-5.0	-13.6	-19.2			
Facade 03	Leq,d	3.2	1.0	-10.0	-2.0	-10.5	-24.7				
Facade 04	Leq,d	-3.4	-6.4	-16.0	-7.9	-14.8	-27.5				

## SurfThru Fresno

### Contribution spectra - Situation 1 - IDC 120HP Pred - SP

Source	Time slice	Sum	63Hz	125Hz	250Hz	500Hz	1kHz	2kHz	4kHz	8kHz	16kHz
		dB(A)	dB(A)	dB(A)	dB(A)	dB(A)	dB(A)	dB(A)	dB(A)	dB(A)	dB(A)
Roof 01	Leq,d	11.1	4.8	-4.0	8.6	3.4	-8.3	-14.8	-26.8		
Transmissive area 01	Leq,d	52.4	29.6	35.0	43.6	46.4	47.5	46.3	37.7	17.6	
Transmissive area 01	Leq,d	38.6	22.4	26.5	35.0	33.3	29.3	25.1	14.2	-10.2	
Vacuum 1	Leq,d	20.9	-3.3	-1.0	2.5	0.9	8.7	16.8	18.1	-0.9	
Vacuum 2	Leq,d	21.0	-3.1	-0.8	2.6	1.0	8.7	16.8	18.1	-0.9	
Vacuum 3	Leq,d	22.3	-2.6	-0.3	2.8	1.8	10.3	18.2	19.5	0.3	
Vacuum 4	Leq,d	25.4	-1.9	0.6	3.2	3.7	13.1	21.0	22.8	5.1	-30.2
Vacuum 5	Leq,d	26.5	-0.6	2.5	4.2	4.7	14.3	22.2	23.9	6.2	-29.2
Vacuum 6	Leq,d	29.6	3.0	7.4	7.5	7.6	16.9	24.8	27.3	11.8	-16.5
Vacuum 7	Leq,d	30.1	3.0	7.4	8.2	8.6	17.3	25.2	27.9	12.6	-15.8
Vacuum 8	Leq,d	29.4	3.1	7.5	8.3	7.8	16.4	24.3	27.1	12.2	-15.8
Vacuum 9	Leq,d	29.2	3.1	7.6	8.3	7.3	15.8	23.8	27.1	13.9	-13.6
Vacuum 10	Leq,d	16.0	-5.3	-3.6	-1.3	-4.0	3.4	12.1	12.7	-7.3	
Vacuum 11	Leq,d	21.3	-5.6	-3.7	-1.1	-2.5	9.1	17.2	18.6	0.3	-35.6
Vacuum 12	Leq,d	25.1	-5.4	-3.4	-0.9	-1.3	12.9	20.8	22.5	4.5	-32.0
Vacuum 13	Leq,d	26.0	-5.0	-3.0	-0.7	1.4	13.9	21.7	23.4	5.3	-31.5
Vacuum 14	Leq,d	25.8	-4.3	-2.2	-0.4	1.5	13.7	21.4	23.2	5.3	-31.2
Vacuum 15	Leq,d	25.9	-2.1	0.6	1.2	2.0	13.8	21.5	23.3	5.5	-30.5
Vacuum 16	Leq,d	31.4	3.9	8.5	9.5	9.1	18.5	26.4	29.2	14.5	-11.7